

TCO Certified

Generation 9 for all-in-One PCs





Draft 2

TCO Certified

Generation 10, for all-in-One PCs



Draft 2

TCO Certified – driving sustainable development in IT products

Established in 1992, TCO Certified is a global sustainability certification for IT products. [The organization behind TCO Certified is TCO Development](#). Certificates are valid worldwide and can be used as proof in all countries, without the need for local adaptation. TCO Certified is ~~currently~~ available [with both general and product-specific criteria](#) for ~~eleven~~ [several](#) product categories: displays, notebooks, tablets, smartphones, desktops, all-in-one PCs, projectors, headsets, servers, network equipment and data storage. ~~The organization behind~~ TCO Certified is [also available with only the general criteria for any IT product after consultation with](#) TCO Development.

Comprehensive criteria with a life cycle perspective

Certified products must meet comprehensive environmental and social criteria throughout the life cycle. The criteria are science-based and developed in an open process with TCO Development's international network of stakeholders, which includes users, buyers, industry, NGOs, researchers and subject matter experts. To address the most pressing sustainability challenges and stay current with the latest technology developments, a new generation of TCO Certified is released every three years.

A third-party certification, independently verified

TCO Certified is a third-party certification, independent of the IT industry and buyers. It meets the requirements in ISO 14024 Ecolabel Type 1 and has been approved by the [Global Ecolabelling Network](#) as part of the GENICES peer review process. Independent verification organizations, accredited to ISO 17025, verify that products conform with all criteria in TCO Certified. Verification is done both before and after certification, throughout the full validity period of the certificates.

How to apply for certification

At tccertified.com, you'll find a guide that explains the certification process and lists what you need to do to apply for certification of your products. Compliance with all criteria in TCO Certified is independently verified. It generally takes three to five weeks to receive the certificate, once all documents and the product sample are delivered to the verification organization.

Need help?

Need help getting started? Or, would you like us to explain the certification process in more detail? Our certification team is always here to help. Email us on certification@tcodevelopment.com. Our approved, independent verifiers around the world are also at your disposal, and are able to explain the criteria and certification process in your local language. Contact details are available at tcocertified.com.

Draft 2

About this document

This is TCO Certified, generation [910](#), for all-in-one PCs, released in [December 2021](#)~~XXX 2024~~. An all-in-one PC is defined as a stationary computer and display in a single unit. The definition includes stationary thin clients. All [powerexternal](#) cables and external power supplies are considered a part of the all-in-one PC. All other peripherals (i.e. keyboard and mouse) that may be shipped with the all-in-one PC are not covered by TCO Certified. For displays that are not light emitting or have less than 8 bit RGB color (i.e reflective, E-ink, etc), some visual ergonomics criteria are not applicable.

Available for 11 product categories

~~TCO Certified is available for 11 product categories and they all have the same generation number: generation 9. A majority of the criteria are the same for all product categories.~~

The criteria include:

Mandate: A description of the requirements that needs to be fulfilled, and how conformity is verified. Forms and signatures for application are available in chapter 11 of this document.

Definitions: Explanations of important terms relevant to the criterion.

References: References to sources, presented in chapter 10.

Clarifications: Further details and explanations of the mandate.

Compliance with criteria is independently verified

Compliance with the criteria is verified by verification organizations (verifiers) independent of both the certification body (TCO Development), the applicant and the brand owner. Each criterion includes a description of the proof that must be submitted to the verifier, and to TCO Development together with the application form. This may be a test report or a verification report:

1. A test report presents the results from tests conducted by a test facility accredited to ISO 17025, and is issued by that same facility.
2. A verification report is issued by a verifier approved by TCO Development and includes a summary and a result (pass or fail) based on either:
 - a test report issued by the same test facility,
 - a test report issued by a different test facility, or
 - certificates or other proof from the company or brand owner applying for the certificate.

Editions of TCO Certified

When we publish a new generation of TCO Certified, our ambition is always to maintain criteria levels until the next generation of TCO Certified is launched, which typically happens after three years. Several editions of the criteria document may be released, but will be considered only as updates within the ninth generation, with improved precision of the mandates, test methods and clarifications. To ensure that all currently certified products comply with the new edition of the criteria document, the criteria levels are never raised within a generation.

Draft 2

Table of contents

1 Product and sustainability information	13
1.1 Information to end users	15
1.1.1 Mandate	15
1.1.2 Clarification	17
1.2 Product specification	21
1.2.1 Mandate	21
1.2.2 Clarification	23
1.3 Unique product identifier	25
1.3.1 Mandate	25
1.3.2 Clarification	26
2 Socially responsible manufacturing	32
2.1 Supply chain responsibility	36
2.1.1 Mandate	36
2.1.2 Clarification	40
2.2 Supply chain transparency	57
2.2.1 Mandate	57
2.2.2 Clarifications	59
2.3 Anti-bribery management system	62
2.3.1 Mandate	62
2.3.2 Clarification	64
2.4 Responsible mineral sourcing	65
2.4.1 Mandate	65
2.4.2 Clarifications	66
2.5 Process chemicals management	71
2.5.1 Mandate	71
2.5.2 Clarification	72
3 Environmentally responsible manufacturing	76
3.1 Environmental management system	77
3.1.1 Mandate	77
3.1.2 Clarification	78
3.2 Renewable energy	79
3.2.1 Mandate	79

3.2.2 Clarification	81
3.3 Energy management system	87
3.3.1 Mandate	87
3.3.2 Clarification	87
3.4 Post-consumer recycled content	89
3.4.1 Mandate	89
3.4.2 Clarification	90
3.5 Product carbon footprint	93
3.5.1 Mandate	93
3.5.2 Clarification	94
3.6 Product carbon footprint reductions	97
3.6.1 Mandate	97
3.6.2 Clarification	98
4 User health and safety	99
4.1 Electrical safety	100
4.1.1 Mandate	100
4.1.2 Clarification	100
4.2 Alternating electric fields	101
4.2.1 Mandate	101
4.2.2 Clarification	101
4.3 Alternating magnetic fields	108
4.3.1 Mandate	108
4.3.2 Clarification	109
4.4 Acoustic noise	114
4.4.1 Mandate	115
4.4.2 Clarification	115
4.5 Vertical tilt	118
4.5.1 Mandate	118
4.5.2 Clarification	118
4.6 Vertical height	120
4.6.1 Mandate	120
4.6.2 Clarification	121
5 Product performance	123
5.1 Energy efficiency	124
5.1.1 Mandate	124
5.1.2 Clarification	125

5.2 Display resolution	131
5.2.1 Mandate	131
5.2.2 Clarification	131
5.3 Correlated color temperature	133
5.3.1 Mandate	133
5.3.2 Clarification	134
5.4 Color gamut	135
5.4.1 Mandate	135
5.4.2 Clarification	136
5.5 Color uniformity	138
5.5.1 Mandate	138
5.5.2 Clarification	138
5.6 Color uniformity – angular dependence	141
5.6.1 Mandate	141
5.6.2 Clarification	141
5.7 Color grayscale linearity	145
5.7.1 Mandate	145
5.7.2 Clarification	147
5.8 Luminance level	148
5.8.1 Mandate	148
5.8.2 Clarification	148
5.9 Luminance uniformity	152
5.9.1 Mandate	152
5.9.2 Clarification	152
5.10 Luminance uniformity – angular-dependence	155
5.10.1 Mandate	155
5.10.2 Clarification	155
5.11 Luminance contrast – characters	162
5.11.1 Mandate	162
5.11.2 Clarification	162
5.12 Luminance contrast – angular dependence	167
5.12.1 Mandate	167
5.12.2 Clarification	168
5.13 Black level	169
5.13.1 Mandate	169
5.13.2 Clarification	169

5.14 Grayscale gamma curve	171
5.14.1 Mandate	171
5.14.2 Clarification	173
6 Product lifetime extension	174
6.1 Product warranty	176
6.1.1 Mandate	176
6.1.2 Clarification	177
6.2 Replaceable components	181
6.2.1 Mandate	182
6.2.2 Clarification	182
6.3 Standardized connectors	192
6.3.1 Mandate	192
6.3.2 Clarification	193
6.4 Secure data removal	194
6.4.1 Mandate	194
6.4.2 Clarification	195
6.5 Security and functionality software updates	196
6.5.1 Mandate	196
6.5.2 Clarification	197
7 Reduction of hazardous substances	199
7.1 Heavy metals	201
7.1.1 Mandate	201
7.2 Halogens	203
7.2.1 Mandate	205
7.2.2 Clarification	206
7.3 Non-halogenated substances	207
7.3.1 Mandate	209
7.3.2 Clarification	209
7.4 Plasticizers	214
7.4.1 Mandate	215
7.4.2 Clarification	216
7.5 Hazardous substances in product packaging	217
7.5.1 Mandate	217
7.5.2 Clarification	217
8 Material Recovery	218
8.1 Product packaging	220

8.1.1 Mandate	220
8.1.2 Clarification	221
8.2 E-waste management	222
8.2.1 Mandate	222
8.2.2 Clarification	223
8.3 Material coding of plastics	226
8.3.1 Mandate	226
8.3.2 Clarification	227

Draft 2

1 Product and sustainability information

- The IT industry is complex and finding reliable data about products and manufacturing conditions can be a challenge.
- The lack of verified product claims can lead to unfair competition between brands as well as greenwash.
- Accurate and comparable information helps both brands and purchasers make informed decisions and measure their sustainability progress.

Transparency improves decision-making

To drive sustainable development in the complex IT industry, accurate and comparable information about products and manufacturing conditions is needed. Transparency around this type of data also helps purchasing organizations make more informed product choices, and measure and report the true sustainability impact of the certified models they actually buy. Another positive effect of giving purchasers and industry access to verified product claims is that it helps IT brands compare their sustainability performance with peers, and reduces the risk of unfair competition and greenwash.

Our approach: Providing access to independently verified sustainability data

To increase transparency around certified products, [more than 40 new Sustainability Performance Indicators \(SPIs\) are added](#) data is collected in TCO Certified, [generation 9. SPIs make. This data makes](#) it possible to [identify products that are best in class from a measure and report on the sustainability perspective and exceed the requirements](#) impact of TCO Certified [using IT products](#). To ensure accurate reporting, gathered data is verified by independent experts. [In those cases where collected data may be published in a non-anonymous format towards purchasers or other stakeholders, this is explicitly written in the criterion mandate under the headline "The following is submitted to TCO Development and may be published"](#).

Criteria in chapter 1 focus on:

- [Requiring that sustainability data is reported and independently verified.](#)
- [Improving product identification of certified product models.](#)
- Helping [the end user to users](#) find information on TCO Certified, and what the certification includes.

- Making sure that the product specification of certified products is correct.

Draft 2

1.1 Information to end users

Background

End users must clearly be able to identify which products are certified and what sustainability features the product fulfills.

Applicability

All product categories.

References

The license agreement between TCO Development and the applicant/brand owner.

1.1.1 Mandate

- a. The information document for end users must be written in English or in the local language of the country where the product is to be sold. It must accompany the product in at least one of the following ways:
 1. As a separate ~~printed or~~ digital document found together with the product in the packaging.
 2. Included in a ~~printed or~~ digital user manual.
 3. As a separate digital document that is hosted on the brand owner's website. In this case a direct link to the document must be included in the ~~printed or~~ digital user manual mentioned above.
 4. As a link to the digital document, on the product page that is redirected to when scanning the data carrier as specified in criterion 1.3 Unique product identifier.
- b. The product and its retail packaging must be labeled with the TCO Certified logo. See clarifications for details.
- c. "TCO Certified" must be mentioned on the brand owner's website(s) where the specific certified product is marketed and or sold.

Submit the following to an approved verifier:

A completed and signed product form (chapter 11.3).

Submit the following together with the application to TCO Development:

A copy of the verification report(s) from a verifier approved by TCO Development.

Draft 2

1.1.2 Clarification

Products that are designed to be installed in a rack (supporting framework to hold hardware modules, typically servers, data storage products and networking equipment) are excluded from "1.1.1 b - labeling of the product and packaging".

1.1.1 A - information document for end users

No editorial changes to the information document for end users are accepted without consent from TCO Development. The information document for end users is available at tcocertified.com.

If the applicant is separate from the brand owner, the applicant must ensure that the brand owner agrees to fulfill their part of this requirement.

The mandate is fulfilled in one of the following ways:

~~1. As a separate printed or digital document~~

~~The information document for end users in print or on digital media is placed together with the product in the packaging.~~

~~2. In a printed or digital user manual~~

~~The information document for to end users is included in as a printed link or page in the digital user manual that accompanies the product when it is distributed to the end user. The content of the document, with the headline "TCO Certified", must be found in a separate chapter of with the user manual and be included in the table of contents.~~

~~3. As a separate digital document that is hosted on the brand owner's website.~~

~~The information document for end users is placed on the brand owner's website. A direct link to the information document is placed in the printed or digital user manual that accompanies the product when it is distributed to the end user. headlined "TCO Certified must be a separate headline in the user manual. The headline must be" that is visible in the table of contents.~~

1.1.1 B - labeling of the product and packaging

The TCO Certified logo must be displayed in one of the following ways:

Alternative A

On a permanent or temporary label. Temporary labels must be affixed to the product with an adhesive or cling-type application. The packaging material that is supposed to be removed in order to get the full functionality of a product (such as a screen protector) is defined as packaging material and not the product in this mandate and thus may not be the place for the product logo.

- a. The logo must be visible on the top or front of the product. (The front of the product is defined as the surface seen when viewing the product from the front

and may include the stand. The top is defined as the surface that is seen from the top and the back is the surface that is seen from the back.)

- b. The minimum size of the logo is 16mm in width and 10mm in height.
- c. If the logo is to be placed alongside other logos or graphic elements, a minimum of 2,5mm padding must be used on all sides of the TCO Certified logo.

Exception

If the top and front of the product don't have a contiguous and coplanar area (area used for display or touch input are excluded) which is at least 16mm in width or 10mm in height, then the logo may be placed on the back side of the product.

or

Alternative B

Via electronic labeling displayed on the screen [or digital product picture](#) in one of the below ways:

- a. During the startup of the product:
The logo must cover at least 1% of the screen. The logo must be legible and be in color, black, or white; must appear at system start-up, and must be displayed for a minimum of 0,5 seconds.
- b. Via a shortcut on the desktop screen of the product. The shortcut must be in the form of the TCO Certified logo in color and clicking it should link to "the information document for end users" available at tco certified.com.

~~TCO Certified logo as a part of~~

- c. If the product ~~picture~~ does not have an electronic display and do not have a continuous coplanar area (area used for display or touch input are excluded) which is at least 16mm in width or 10mm in height and without other logos or markings:

The ~~TCO Certified logo~~ is following must be shown on the first page that is redirected to when scanning the data carrier as specified in criterion 1.3 Unique product picture where identifier without further clicks (scrolling is accepted)

- Full name of certification, including generation

- ~~Certificate number of the product is marketed on the brand owners web site. In the product specification on this page, TCO Certified is also listed with a , that is a link to the “information to end user document” which is the document required under mandate 1.1 point 1.~~ [product page in TCO Certified Product finder](#)
- [An image of the TCO Certified logo](#)

TCO Development will consider alternative proposals for electronic labeling on a case-by-case basis.

The retail packaging of the product must be labeled with the TCO Certified logo:

- a. The minimum size of the logo must be 16mm in width and 10mm in height.
- b. If the logo is to be placed alongside other logos or graphic elements, a minimum of 2,5mm padding must be used on all sides of the TCO Certified logo.

The certificate owner and brand owner must also conform with all the other logo rules on color, design, marketing, etc., that are specified in the TCO Certified license agreement appendix 2. The following two paragraphs (§2.2 and §2.5 in appendix 2 of the license agreement) are replaced by the rules listed above if a conflict occurs:.

Paragraphs that may be replaced

~~§2.5 — The TCO Certified logo must at all times be reproduced in a quality that allows the text of the TCO Certified logo to be read under normal circumstances. Recommended minimum size for the trademarks TCO Certified and TCO Certified Edge can be found in “Using the TCO Certified brand” guide available at teocertified.com. If there are limitations and a smaller or different type of logo is used this must first be agreed on in writing with TCO Development.~~

1.1.1 C - Mention of TCO Certified on the brand owner website

- The inclusion of “TCO Certified” only needs to be represented as TEXT - i.e. a link to a specific page is not necessary.
- Instead of mentioning “TCO Certified” directly on the brand owners website(s), the brand owner can fulfill this requirement by including “TCO Certified” as TEXT in a product specific PDF file if it is accessible from the brand owner's website(s) where the specific certified product is marketed and or sold.

To fulfill this mandate the brand owner must submit a description on where and how the inclusion of “TCO Certified” as TEXT can be found for certified products. The description must include a general example of where the TEXT “TCO Certified” will be represented. The description must be submitted to the verification organization. If the location where TCO Certified will be mentioned as TEXT is changed, a new description must be submitted.

1.2 Product specification

Background

It is important to ensure that each product to be certified ~~corresponds exactly to the product specification~~ is described accurately in the test report and certificate. Therefore, a physical sample of each product to be certified must be sent to an approved verifier, that examines it carefully to ensure that product marking and physical aspects conform with the reported information from the applicant or brand owner. Product weight is an indication of the amount of potential e-waste at end-of-life. By decreasing the product weight, e-waste can be reduced.

Definition

The marking label is a label with the product's electrical rating (voltage, frequency, current), the manufacturer's name, trademark or identification mark, and the manufacturer's model or type reference according to IEC 62368-1 clause 4.1.15.

Applicability

All product categories.

References

1.1.

1.2.1 Mandate

- ~~• A product specification of the typical product.~~
- A marking label must be provided for the product.
- The total weight of the typical heaviest product configuration ~~and including the~~ power supply and cables (without packaging) in kg must be reported.

Submit the following to an approved verifier:

- A copy of the marking label, for the product and all external power supplies.
- A product specification of the heaviest configuration.
- A completed and signed product form (chapter 11.3).

~~Submit~~ The following ~~together with the application~~ is submitted to TCO

Development:

- A copy of the verification report(s) from a verifier approved by TCO Development.

The following is submitted to TCO Development and may be published:

- The total weight of the ~~typical~~**heaviest** product configuration ~~and~~**including** power supply ~~and cables~~ (without packaging) in kg ~~must be reported in TCO-Certified Portal~~.
-

Draft 2

1.2.2 Clarification

The template must be completed with the requested information about the product. A type key that includes an asterisk (*) for unidentified characters, if any, in the model name and for other identification names must be submitted to the verifier. Only two * may be used in the model type key and each * must include two or more options.

The typical product **Worst case** configuration

There might be several configurations of a product covered by the same certificate. It is necessary that the verification of compliance cover all these configurations. Therefore, the independent verifier must determine the most likely worst-case configuration for compliance with each criterion in TCO Certified. This configuration must be specified in the test reports under each criterion where worst case configuration is used.

The worst-case configuration must be available for purchase. It must be defined as ~~the~~ through a unique brand owner code, a unique product configuration which is expected to be manufactured in the largest number identifier, or a list of configuration choices that are available at the time of purchase. *If there are several versions of the same component (e.g. due to different suppliers) and the buyer cannot influence which version they get, then the worst-case version of the component must be reported.*

~~The total weight includes the product and any power supply unit and power cable needed to power the device.~~

Sustainability performance indicator(s):

~~Product weight is an indication of the amount of potential e-waste at end-of-life. By decreasing the product weight, e-waste can be reduced. The product weight (in kg) of the typical configuration of the product including any power supply but excluding packaging must be reported by the brand owner. A product weight tolerance of +/- 10% is accepted.~~

1.3 Sustainability performance indicators

Draft 2

1.3 Unique product identifier

Background

Sustainability is a long term goal and therefore a responsible way to work with sustainability is through a long term strategy. Improvements must often be phased in gradually and requires planning and preparation. The sustainability performance indicators will measure the development of products and brand owners, enabling new criteria levels in future generations of TCO Certified to be challenging but yet reasonable, and ensure that the most relevant parts of the product life cycle is covered.

The sustainability performance indicators also measure the sustainability benefits that the certified products create, and track this over time. A purchasing organization can use the sustainability performance indicators in sustainability reporting and, for example, implement climate compensation or other sustainability related measures connected to the sustainability impact of the product.

The criteria ensure that certified products are labeled with a data carrier connected to a unique product identifier. This facilitates circular value chains, enabling efficient and reliable identification of more sustainable products in the marketplace and preparing the product for upcoming EU directives on digital product passports.

Applicability

All ~~in one~~ PCs product categories.

Definitions

GTIN: Global Trade Item Number

Unique product identifier: A unique string of characters for the identification of products that also enables a web link to the digital product passport.

Digital product passport: a set of data specific to a product accessible via electronic means through a data carrier.

Data carrier: a two-dimensional symbol or other automatic identification data capture medium that can be read by a device.

Serial number: Any alphanumeric string that functions as a persistent and unique identifier for an individual item.

1.3.1 Mandate

- ~~All sustainability performance indicators must be evaluated.~~

Part 1:

The certified product must have a Data carrier containing a Unique product identifier As specified in GS1 digital link standard or equivalent.

Part 2:

When the data carrier is scanned by a device, it must redirect to a website displaying unit-specific product information.

Submit the following to an approved verifier:

- Physical Sample of product equipped with data carrier. Or documentation showing that the product will be marked in the same way as a previously assessed and approved product.
- Sample URL (as encoded in the data carrier)
- Sample URL for the website displaying unit-specific product information.
- GTINs assigned for the product, using the UPI template
- A completed and signed product form (chapter 11.3)).

Submit The following together with the application is submitted to TCO

Development:

- A copy of athe verification report(s) from a verifier approved by TCO Development.
- ~~All sustainability performance indicators must be reported in TCO Certified Portal.~~

The following is submitted to TCO Development and may be published:

- The GTINs assigned with the product, either by range or specific id's.

1.3.2 Clarification

The first time a brand applies for a TCO Certified Generation 10 certificate, A period of 12 months may be granted to implement functionality so that the scanning of the data carrier leads to a unit-specific website.

Unique product identifier specifications

The Unique Product Identity must be encoded into the data carrier according to GS1 digital link URI syntax standard. The minimum required information to include is:

1. Global Trade Identification Number(GTIN) as provided for in standard ISO/IEC 15459-6

2. Product serial number

Example URL: <https://id.brand.com/01/09506001343376/21/4EEE2F4654CA424>

Description of example URL: https://subdomain.domain_name.com/gtin/serialnumber



See Section 5 in [GS1 Digital Link Standard: URI Syntax](#) for more Examples of GS1 Digital Link URIs. It is recommended, but not mandatory, to use the best practices guide from GS1 [GS1 Digital Link: Best practices for creating your QR Code powered by GS1](#)

Data carrier specifications

Accepted types of data carriers:

[Qr-code or data matrix](#)

[To ensure data carrier quality, the following standards must be followed:](#)

[If data carrier is a QR-code: ISO/IEC 18004:2015](#)

[If data carrier is a data matrix: ISO/IEC 16022:2006](#)

Placement of data carrier on the product

- [A. The data carrier must be placed on the outer casing or on the marking plate.](#)
- [B. The data carrier must be placed on a flat surface on the product.](#)
- [C. The data carrier must be accessible without using tools.](#)
- [D. The brand owner submits documentation or a sample that shows how the product will be marked with the data carrier to an approved verifier.](#)

Products made up of multiple detachable parts:

[The data carrier should be attached to at least one of the parts.](#)

Data carrier on product packaging.

[It is not required to label the product packaging with an additional copy of the data carrier with the unique product identifier, but it is allowed.](#)

Data carrier Size

Use Section 5.12.3 GS1 symbol specification in GS1 General Specifications**New applications**

A verification report for the sustainability performance indicators must be issued by an approved verifier and the results must be reported to TCO Certified Portal.

Reassessments

Changes made to the product or its manufacturing may affect the sustainability performance indicators. The applicant can choose to do a re-assessment or not. To do a re-assessment, the necessary documentation (and in some cases the product) must be sent to a verifier that issues a verification report for the sustainability performance indicators and report the new data to TCO Certified Portal.

Quoting sustainability performance indicators in the marketing of a product

The following guidelines apply to all communications about sustainability performance indicators. Quoting or referring to the sustainability performance indicators in conjunction with the brand name TCO Certified is not allowed unless a written agreement to do so is made with TCO Development.

“Worst case” reporting

If the verifier has conducted a “worst case” testing and accepts a number of similar configurations of the product in the issued verification report based on these tests, the sustainability performance indicators may also be the same for all accepted configurations and thus represented by the worst case configuration.

1.3.3 Sustainability Performance Indicators (SPI) list

The sustainability performance indicators are collected through the SAQ, submissions to TCO Development, or during the application process. All sustainability performance indicators must be evaluated. The results will be used to benchmark the performance of products within different aspects of the certification and to provide purchasers with information on sustainability benefits of certified products.

All SPIs marked with “X”

are collected annually either through the SAQ or together with annual submissions.
(X = Always collected during annual reporting)

All SPIs marked with “Y”

are collected by the verification organization during application and product testing.
(Y = Always collected during product testing/verification/application process)

All SPIs marked with “Z”

are considered beyond the scope of mandates in TCO Certified and are therefore not required for compliance with TCO Certified. Products will receive the lowest classification if no data is provided for the evaluation. By submitting the additional data, the product will always receive a better classification than if no data is submitted.

(Z = Additional information by the applicant/brand owner is needed)

The following is a summary of all the sustainability performance indicators collected.

SPI's described under product specification

- ~~Y~~ 1.2 The total weight of the product and power supply (without packaging)

SPI's described under socially responsible manufacturing criteria (Chapter 2)

- ~~X~~ 2.2 (SAQ 1.1) Level of brand owner communication of CoC in the supply chain
- ~~X~~ 2.2 (SAQ 2.1) The level of the supply chain identified
- ~~X~~ 2.2 (SAQ 2.2) The level of transparency for final assembly factories and smelters
- ~~X~~ 2.2 (SAQ 2.2) The percentage of publicly listed factories for certified products.
- ~~X~~ 2.2 (SAQ 3.1) The level of brand owner due diligence on suppliers not owned
- ~~X~~ 2.2 (SAQ 3.2) The level of brand owner audits and follow up on suppliers not owned
- ~~X~~ 2.2 (SAQ 4.1) Level of brand owner Initiatives to avoid child labour
- ~~X~~ 2.2 (SAQ 4.2) Level of brand owner remediation process for child labour
- ~~X~~ 2.2 (SAQ 5.1) Level of brand owner requirement on excessive temporary contracts
- ~~X~~ 2.2 (SAQ 5.2) Level of brand owner engagement in living wage programs
- ~~X~~ 2.2 (SAQ 6.1) Level of brand owner process to avoid excessive overtime
- ~~X~~ 2.2 (SAQ 7.1) The level of factories with trade union or worker representatives
- ~~X~~ 2.2 (SAQ 7.2) Level of brand owner involvement with union or worker representatives
- ~~X~~ 2.2 (SAQ 7.3) Level of brand owner work to counter union discrimination
- ~~X~~ 2.2 (SAQ 8.1) Level of brand owner work to improve management and worker dialogue

SPI's described under environmental responsible manufacturing criteria (Chapter 3)

- ~~X~~ 3.2 The energy efficiency indicators for each final assembly factory
- ~~Y~~ 3.4 Percentage of post consumer recycled plastics by weight versus the total weight of all plastics (Class A-G):
- ~~Y~~ 3.4 Percentage of identified post consumer recycled materials by weight versus the product weight (Class A-G):
- ~~Z~~ 3.5 Classification of PCF method (Class A-E)

- ~~Z 3.5 Classification of data age (Class A-E)~~
- ~~Z 3.5 Classification on availability of PCF (Class A-D)~~

SPI's described under user health and safety criteria (Chapter 4)

- ~~Y 4.4 The sound power level (LWAd) in operating and Idling mode~~

SPI's described under product performance criteria (Chapter 5)

- ~~Y 5.1 Energy efficiency~~
- ~~Y 5.2 The pixel density~~
- ~~Y 5.3 The default CCT difference $\Delta u'v'$ compared to D65~~
- ~~Y 5.4 The minimum color triangle area~~
- ~~Y 5.5 The color uniformity~~
- ~~Y 5.6 The color uniformity—angular dependence~~
- ~~Y 5.7 The largest $\Delta u'v'$ measurement of color grayscale linearity~~
- ~~Y 5.8 The maximum and minimum (if applicable) luminance level~~
- ~~Y 5.9 The luminance variation~~
- ~~Y 5.11 The luminance contrast~~
- ~~Y 5.12 The luminance contrast—angular dependence~~
- ~~Y 5.13 The black level luminance~~
- ~~Y 5.14 Grayscale gamma curve~~

SPI's described under product lifetime extension criteria (Chapter 6)

- ~~Y 6.1 Classification of warranty period (Class A-G)~~
- ~~Z 6.1 Classification of extended warranty availability (Class A-G)~~
- ~~Z 6.1 Classification of public repair policy (A-G)~~
- ~~Z 6.2 Classification of fasteners and connectors (Class A-D)~~
- ~~Z 6.2 Classification of necessary tools for repair/upgrade, (Class A-E)~~
- ~~Z 6.2 Classification of availability of spare parts by target group (Class A-E)~~
- ~~Z 6.2 Classification of availability of spare parts by duration of availability (Class A-D)~~
- ~~Z 6.2 Classification of availability of comprehensive information (Class A-G)~~
- ~~Y 6.4 Classification of Media sanitization solution (Class A-B)~~
- ~~Y 6.4 Classification of Compliance with EN 45554:2020 (Class A-B)~~

SPI's described under material recovery criteria (Chapter 8)

- ~~Z 8.2 Membership in multi-stakeholder initiatives working towards solving the problems connected to e-waste (Class A-C)~~
- ~~X 8.2 Use of internationally accredited reuse and recycling facilities (Class A-D)~~
- ~~Z 8.2 Ratio of compensated versus manufactured products (Class A-G)~~

[as a guide to select an appropriate label size to encode the Digital link URL domain name and product serial number.](#)

Draft 2

2 Socially responsible manufacturing

- Poor working conditions are common throughout the IT product supply chain.
- Child labor, forced labor, excessive overtime and hazardous substances are a risk to workers' health and lives.
- To drive social responsibility, a structured system for continuous improvements is needed, along with strict monitoring to ensure problems are [solved/resolved](#).

Social risk is present throughout the supply chain

Much of IT product manufacturing is carried out in low-wage countries where the labor market lacks clear regulation, and the protection of workers is insufficient. Poor working conditions occur throughout the supply chain. Sustainability risks include child labor, forced labor, and hazardous chemicals used in manufacturing. Excessive overtime leaves a worker with little to no time over for rest, recreation, family or further education. The mineral industry is connected to armed conflicts and human rights abuses, severe health problems for workers, and environmental degradation. As in many industries, the risk of bribery is also present. This must be counteracted as it hinders development, erodes justice, undermines human rights and interferes with the fair and efficient operation of markets.

Our approach: driving worker safety, human rights and closing non-conformities

Driving social responsibility throughout the complex IT product supply chain requires a clear and systematic approach. TCO Certified includes a framework that encourages proactive work and helps brand owners structure their work with sustainability. Corrective action plans must be developed and implemented within a set timeframe. To drive change where it's needed the most, monitoring of high-risk factories is intensified.

Criteria in chapter 2 focus on:

- Ensuring safer working conditions by requiring that the code of conduct is implemented throughout the supply chain.
- Guiding the industry to more sustainable practices with a structured system for continuous improvement.
- Requiring transparency about which [sub](#)-suppliers are being used to increase accountability.
- Taking the next step in combating corruption in the supply chain by requiring compliance with the more ambitious anti-bribery standard ISO 37001.

- Continuing independent verification of due diligence all the way to the source of the minerals, to ensure that minerals are sourced responsibly.
- Requiring that all [cleaning](#) process chemicals are assessed by an independent toxicologist and benchmarked as a safer alternative before being used in the manufacture of certified products. The same principle applies also to flame retardants and plasticizers, covered in chapter 7.

Draft 2

Definitions ~~Chapter 2~~

3TG: [tin, tungsten, tantalum, gold.](#)

Anti-bribery management system: A system designed to help organizations ~~instill~~[instill](#) an anti-bribery culture and implement appropriate controls to detect and address bribery.

Brand owner: The company or organization owning or controlling the brand name of the product.

Bribery: Giving or receiving an unearned reward to influence someone's behavior.

Business licence: A business licence covers an independent work unit, which means it has its own ~~separated~~[separate](#) production areas, operation and management system, including but not limited to recruitment, working hours system, wage and benefit system, factory rules, etc. and all employees that under contract are dedicated to that factory.

Cleaning solvents: Chemicals and chemical mixtures used to remove contaminants, unwanted materials, and/or manufacture process residues (e.g. lubricants, adhesives, solder flux residues, plastic residue, and mold releases). Examples of process chemicals used for cleaning include: solvents, aqueous detergent solutions, stencil/ink removers, adhesive removers, solvent vapor degreaser solutions, ultrasonic parts cleaner solutions, photo-resist strippers, and solder~~_~~defluxing solutions.

Conflict-affected and high-risk areas: Areas in a state of armed conflict, fragile post-conflict areas, ~~as well as~~[and](#) areas witnessing weak or non-existing governance and security, such as failed states. In these areas, there are often widespread and systematic violations of international law, including human rights abuses.

Corrective action plan (CAP): A list of actions ~~that~~ the brand owner is responsible for implementing within a set timeframe; to address a specific problem.

Corruption: Gaining an advantage through illegitimate means. Bribery, abuse of power, extortion, fraud, deception, collusion, cartels, embezzlement and money laundering are all forms of corruption.

CPA: Clean Production Action. Developers of GreenScreen® for Safer Chemicals.

Final assembly factory: A final assembly factory is where the final assembly of the certified product ~~is taking~~[takes](#) place and is defined as the whole operation covered by a business license.

[If the final assembly of the product is divided over more than one factory, all are considered final assembly factories.](#)

Licensed GreenScreen Profilers: Toxicology firms licensed by CPA to provide GreenScreen assessment services for a fee to clients.

Next-tier major suppliers: Suppliers to the final assembly factory of parts and packing materials for the certified product. ~~Major suppliers are determined by the auditee management system (annual spending, critical component, more than once purchase...) that has been verified by an accepted auditor.~~

Process chemical inventory: A record ~~kept by~~ the factory ~~keeps~~ showing ~~at least~~ the process chemicals used ~~in the to~~ manufacture ~~of~~ certified products.

Process chemicals: Chemicals (individual chemicals or mixtures) used during the manufacture of a product and/or to ~~carry out maintenance of/maintain~~ related production equipment. Process chemicals are not intentionally fully incorporated into the product. Cleaning agents, lubricants and additives are examples of process chemicals.

Refining: A process that increases the grade or purity of a metal.

Responsible Minerals Assurance Process (RMAP): Independent third-party assessment of smelter and refiner management systems; and sourcing practices; to validate conformance with RMAP standards.

Responsible minerals initiative (RMI): Member initiative for ~~the implementation of/implementing~~ minerals supply chain due diligence.

Smelting: The process of applying heat to ore in order to extract a base metal.

SMT: Surface-mount technology is a method in which the electrical components are mounted directly onto the surface of a printed circuit board (PCB). An electrical component mounted in this manner is ~~referred to as~~ called a surface-mount device (SMD).

2.1 Supply chain responsibility

Background

Social responsibility is a continuing challenge throughout the IT supply chain. From raw materials extraction to final assembly, working hours, health and safety and forced labor are examples of industry-wide issues. However, for those who want to drive greater social responsibility, a major issue is the complexity of the IT product supply chain. It includes many suppliers that are spread all over the world.

The most basic aspect of social responsibility in the supply chains is to define who holds the responsibility. After this is done, the level of conformity and the implementation in the supply chains need to be defined. Finally, to make sure that problems are solved and improvements are made, independent verification and follow-up is crucial. Continued monitoring is essential, even after closure. TCO Certified offers a structured platform to guide industry progress:

- The responsibility for correcting non-conformities is placed on the brand owner, which is at the top of the product value chain.
- Define minimum standards of the brand owner code of conduct covering the manufacturing of the certified product.
- We provide a control system to ensure that the brand owner takes ~~the~~ responsibility in the ~~final assembly factories and~~ supply chains of the certified product; and works in a structured way in accordance with the code of conduct.
- By including a system of consequences for continued non-conformities, we ~~create an incentive for~~ incentivise the brand owner to work proactively.

Applicability

All product categories.

References

2.1, 2.2, 2.3

2.1.1 Mandate

By signing this mandate, the brand owner agrees to (1.) the Commitment and agrees to conduct (2) the Structured work. Additionally, TCO Development requires that the brand owner shows (3) Proof of the commitment and the structured work by allowing inspections in the ~~final assembly factories and the~~ supply chains of the certified product, ~~by~~ sharing audit reports and CAPs, and ~~by~~ providing other documented proof described below.

TCO Certified - Generation 10, for all-in-one PCs - draft 2 - 2024 © TCO Development AB. All rights reserved.

1. Commitment

- The brand owner must have a public code of conduct for the manufacture of certified products, ~~that is~~ considered consistent with the following [principles and rights at work](#):
 - ILO's ~~eight core~~[fundamental](#) conventions: 29, 87*, 98*, 100, 105, 111, 138, [155](#), [182](#) and ~~182~~[187](#).
 - The UN Convention on the Rights of the Child, Article 32.
 - All applicable local and national health and safety and labor laws effective in the country of manufacture, and a maximum 60-hour workweek including overtime*.

*See clarifications; 1 and 2

2. Structured work

- ~~When applying for a new certificate,~~ The brand owner must [report all](#)~~register each~~ final assembly ~~factories~~[factory and each factory](#) manufacturing [display panels >10"](#) for the product model(s) that the application covers to TCO Certified Portal.
- ~~The brand owner must and~~ supervise the implementation of the code of conduct at ~~all final assembly factories that the brand owner is using to manufacture the certified product. these factories.~~
- ~~The brand owner must ensure that corrective action plans are developed and implemented within reasonable time, all registered factories have identified and communicated the code of conduct to their next tier suppliers of parts for all non-conformities to the code of conduct that the brand owner is made aware of, at all final assembly factories where certified products are made, and in their supply chains.~~
- ~~Final assembly factories that are registered to TCO Certified Portal must have a management system to identify their next tier major suppliers of parts and packaging for certified products.~~
- ~~A code of conduct consistent with this mandate must be effectively communicated to the next tier major suppliers.~~
- ~~The final assembly factory must have a self-reported risk assessment of their next tier major suppliers.~~

3. Proof

- ~~TCO Development may conduct/commission factory inspections (spot checks) at any SA8000 final assembly factory manufacturing a certified product and may require full audit reports during the certification period in order to assess social commitment and advancement.~~
- [The brand owner code of conduct and communication process must be annually verified during the annual review process.](#)

- [Accepted initial audit reports, closure audit reports and corrective action plans for each registered factory must be uploaded to TCO Certified Portal.](#)
 - The supply chain identification template ([SCIT](#)) must be submitted. [The template must be uploaded](#) to TCO Certified Portal for [each only the](#) registered final assembly factory. [An updated SCIT may be required to be resubmitted at any time.](#)
 - ~~TCO Development may annually select a factory from the list of major next tier suppliers it identifies as higher risk to submit one or more of the following:~~
 - ~~○ An independent audit report in accordance with RBA or SA8000 procedures.~~
 - ~~○ A completed Process Chemical Data Collection (PCDC) Tool.~~
 - ~~○ Proof of an independently verified OHS management system.~~
- [Data on the following suppliers for the following parts must be included in the SCIT:](#)
- [Product housing: Enclosure \(chassis\) including stand: Parts >0.5 grams.](#)
 - [Printed circuit board: Mainboard \(motherboard\) and power board.](#)
 - [External cables: Power and peripheral connecting cables.](#)
 - [Processors and memory: CPU, GPU, chipset, DRAM, RAM, SSD and HDD.](#)
 - [Battery: Remote power source of the product.](#)
 - [Power supplies: internal and external.](#)
 - [Display panel \(all sizes\).](#)
- TCO Development may also require seeing audit reports and corrective action plans from factories further [down up](#) the supply chains of the certified product; to ensure that corrective actions have been successfully implemented.
 - TCO Development additionally requires that supporting documentation be verified by an independent verifier; approved by TCO Development.
 - [TCO Development may commission random factory audits \(spot checks\) at any factories registered to TCO Certified Portal.](#)

Submit the following to an approved verifier:

Once a year at the Senior Management Representative [interview annual review](#):

- ~~The most recent version of~~ The brand owner's public code of conduct communicated to the supply chains of the certified product. The code of conduct must be considered consistent with this mandate.
- Supporting Information on the routines of how management and workers in [the final assembly factories each registered factory](#) are informed about the code of conduct.
- A completed and signed brand owner form covering the certified product. (Chapter 11.1.)

For each application:

- A copy of the factory list in the CB certificate with the names and addresses of all final assembly factories manufacturing the certified product model. If any of these factories are not registered to TCO Certified Accepted Factory List, ~~then~~ the brand owner must submit the factory identification template to register the ~~final assembly~~ factory ~~to the list~~ or prove that the factory is not manufacturing the certified product model.
- [A photo of the display panel marking label.](#)
- [Check that the brand name is listed as compliant without missed due dates on TCO Certified Portal. Any missed due dates will mean a certification application cannot proceed until the required documentation is submitted and the due date is extended or marked compliant.](#)

For each final assembly factory [and factory](#) manufacturing [display panels >10" for](#) the certified product:

- [The most recent independent initial audit ~~and areport~~, corrective action plan for each non-conformity- ~~and closure audit report must be uploaded to TCO Certified Portal.~~](#) The audit interval is determined by the risk category of the factory. The risk category is ~~determined~~[set](#) by the verifier according to the [mandate process described under: Audit report and factory risk categorization.](#)
- The supply chain identification template ([SCIT](#)) must be completed and submitted to TCO Certified Portal [for each registered final assembly factory.](#)

Submit [The following, together with the application is submitted](#) to TCO

Development:

- A copy of a verification report from a verifier approved by TCO Development.
- A copy of an English version of the public code of conduct must be uploaded to TCO Certified Portal.
- [An independent audit, and a corrective action plan for each non-conformity, must be reported to TCO Certified Portal, at an interval determined by the risk category of the registered factory, for the certified product.](#)

[The following is submitted to TCO Development and may be published:](#)

- [The status \(YES/NO\), if all final assembly factories manufacturing the certified product/products are category 3, is automatically collected.](#)

2.1.2 Clarification

General clarifications

The mandate is a social performance mandate, and criteria are based on [the eight ILO's](#) (International Labour Organization) [core fundamental](#) conventions and local legislation. The mandate requires that the brand owner comply with the minimum standards for code of conduct, inspection and corrective action engagement, regarding the [situation at their own and/or their supplier factories manufacturing supply chain of the certified products/product](#).

***[Convention 87 and 98](#):** Collective bargaining and freedom of association: All workers must have the right to form, join and organize trade unions of their choice and to have them bargain collectively on their behalf with employers. In situations where this is restricted under law, employers must allow workers to freely and democratically elect their own representative(s) for the purpose of defending the rights and interests of workers.

* Local labor law: The limit and enforcement of local law regarding working hours [differs/differ](#) tremendously [across the world/globally](#). To harmonize with other initiatives and to find a reasonable level for the industry, the criteria in TCO Certified sets a maximum 60 hour workweek, including overtime, as a global requirement regardless of the local law.

*** [60 hour working week](#):** This criterion sets a global limit for weekly working hours that includes overtime based on ILO convention 1 (56 hours per work week including overtime). An additional four hours per workweek is given to harmonize with SAI and RBA. Therefore, workweeks, including overtime, are not to exceed [a total of 60 hours](#), and ~~that~~ workers [must](#) receive at least 1 day off every 7 consecutive days.

~~To monitor continued conformity during an agreed period of time, when considered necessary the factory will be required to submit workweek data to TCO Development using a workweek data template. TCO Certified has established thresholds for non-compliance with working hours.~~ For factories up to 15000 employees ~~the tolerance for excessive working hours per week in TCO Certified is, the following is applicable:~~

- [Minor non-compliance](#): up to 2% of the total workforce working between 60 and 72 hours per week [for minor](#),
- [Major non-compliance](#): ~~2-15% for major and over%~~ [15% of the total workforce working between 60 and 72 hours per week](#)

- Priority non-compliance: More than 15% for priority. Any working hours of the total workforce working between 60 and 72 hours per week or any percentage of the workforce working above 72 hours per week is considered a priority.

The verification process

Proof documentation must be submitted to an independent verifier approved by TCO Development. It is the verifier's responsibility to request any additional documents necessary for the review. The verifier will evaluate the information received from the brand owner according to the principles described below (1-5).

1. The code of conduct:

The brand owner must have their code of conduct covering the supply chains of the certified product reviewed annually by an approved verifier. If the code of conduct has not changed since the previous annual review, ~~then~~ the brand owner does not have to submit it again. ~~In this instance,~~ The Senior Management Representative (SMR) for supply chain responsibility must report this to an approved verifier. The approved verifier carries out the verification during the annual review process.

- The code of conduct must be ~~considered~~ consistent with:
 - ~~ILO's eight core conventions: 29, 87*, 98*, 100, 105, 111, 138 and 182.~~
 - ~~The UN Convention on the Rights of the Child, article 32.~~
 - ~~All applicable local and national health and safety and labor laws effective in the country of manufacture, and a maximum 60 hour workweek including overtime*.~~
- ~~*See local labor law clarifications all parts under "General clarifications" above.~~ **1. Commitment.**
- The contents of the code of conduct must have been adopted by the brand owner's board and addressed by management.
- The code of conduct must relate to cover the manufacturing of the certified product.

2. Information about the code of conduct:

The brand owner must annually submit a description of how management and workers at all final assembly registered factories manufacturing certified products are informed about all parts of the code of conduct. ~~It will be reviewed by an approved verifier.~~ Proof of training classes or other means of worker training and how the factory measures the effectiveness of the worker training must be submitted for review. The training must be held specifically for the purpose of training and not just part of a regular business review meeting. If there are no changes to the communication routine since the previous annual review, then the brand owner does not have to submit it again. In this instance, the Senior Management

Representative SMR must report this to an approved verifier. The approved verifier carries out the verification during the annual review process.

Examples may be that the brand owner:

has translated Accepted proof of compliance. All parts must be fulfilled:

- Annual training on all parts of the code of conduct into local languages. This shows that the company has made efforts to inform for management and employees about the code's content in their own language.
- has conducted training on the code for employees and/workers or management worker representatives at final assembly/registered factories of the certified product.
- has made suppliers of the certified product complete Training is through workshops, e-learning, or online training programs.
- There is a questionnaire (self-assessment) on their process to assess management and worker understanding of, and conformity with, the code of conduct.

3. **The brand owner form**

The brand owner signs the A completed and signed brand owner form covering the certified product (Chapter 11.1.) to confirm that one or all products that are included in the application to TCO Development complies/comply with this criterion.

4. **Factory registration on TCO Certified Portal**

For each certified product, at/each final assembly factories the brand owner is using to manufacture factory and each factory manufacturing display panels >10" for the certified product must be identified. Also, the final assembly factory's next tier major suppliers for parts and packaging of the certified product must be identified using the supply chain identification template provided by TCO Development. and registered to TCO Certified Portal.

The approved verifier will ensure that final assembly factories are listed on TCO Certified Accepted Factory List and that a completed supply chain identification template has or will be submitted to TCO Certified Portal before the due date stated on the portal.

- Final assembly factories of the certified product must be Factories are registered to TCO Certified Portal Accepted Factory List using the factory identification template.
- The SCIT must be submitted for each final assembly factory for the certified product. It is not necessary to submit a SCIT for the display panel factories.
- The supply chain identification template must be submitted for each final assembly factory covering next tier major suppliers of parts and packaging for the certified product. The template shall primarily be completed by the responsible person at the final assembly factory to verify their supply chain management systems and cover all

~~certified brand owners using the final assembly factory. If judged necessary by TCO Development the brand owner can be required to provide additional information on major next tier suppliers they have direct contracts with to fill in any data gaps. TCO Development may require the responsible person at the final assembly factory to work with an approved verifier to complete the template correctly.~~

~~Data gaps in the template increases the risk for spot check action, such as independent social audits or submitting a Process Chemical Data Collection (PCDC) Tool.~~

- Each time a ~~final assembly~~ factory is removed, added or updated in any way, ~~it is~~ the brand ~~owner's responsibility to~~ owner must ensure that this information is updated on TCO Certified Portal by submitting the ~~correct documentation~~ factory identification template to an approved verifier. The template is downloaded from tcocertified.com.

5. Independent social audit reports

The brand owner must ensure that TCO Certified Portal is continuously updated with the most recent independent initial audit report; and corrective action plans for all non-conformities ~~that were~~ found during ~~this~~ the audit; from all ~~final assembly~~ registered factories manufacturing the certified product.

Brand owners or applicants/manufacturers must submit audit reports and corrective action plans to an approved verifier for upload to TCO Certified Portal. ~~Consistency of the reports are ensured through annual spot checks by TCO Development.~~

~~The~~ Factory audit ~~interval is~~ intervals are determined by the risk category of the factory.

1. Independent audits must be conducted by organizations accredited to ISO 17021 and carried out by SA8000 or RBA lead auditors. ~~An independent party is considered to be a person or body that is recognized as being independent of the parties involved, regarding the issue in question who are APSCA certified. The lead auditor's APSCA membership number must appear in the audit report.~~
2. ~~Types of~~ Accepted audits ~~are~~:
 - a. SA8000,
 - b. RBA VAP,
 - c. Other audit types, if ~~they are~~ independently verified to be of equal quality to one of the accepted audits (a or b). This includes auditor qualification, audit process (e.g. triangulation of non-conformities), reporting and CAP. Verification will be conducted by an approved verifier before an alternative audit is accepted as proof.

Defining the factory risk category and audit intervals

If a newly added final assembly^Δ factory is not yet risk categorized, then new to TCO Certified Portal must be updated with either the latest independent independently audited using an accepted audit report (less than 36 months old), a valid type. Any SA8000 certificate; or proof of an RBA recognition from the factory. The proof of an RBA recognition diploma must be submitted with an the initial audit report showing that working hours are under 60 hours per workweek. Initial audit reports must cover at least this criterion and be an accepted type of audit according to the definition in "Verification process" above. The factory will then be. A factory is assigned a risk category 1, 2 or 3 depending based on the latest audit results. A factory assigned risk category 1, 2 or 3 will reflect the interval, in years, during which a factory must conduct the next initial audit and submit the documentation proof to TCO Certified Portal.

Until the brand owner has submitted a factory audit report, the factory will automatically be categorized as risk category 1. (See below: "Audit report and factory risk categorization".) procedure below.

Brand owners that are new to TCO Certified; or apply applying for certification to a new product category will need to must undergo an additional a risk assessment in order. This is for TCO Development to be sure factory audit assess the likelihood of fulfilling the requirements will be fulfilled within the given time. If the brand owner or factory is considered a high higher risk for not fulfilling the initial audit requirements, then the brand owner is required to submit receiving an extended time (for example: a history of non-compliance), an audit report and a corrective action plan must be submitted before the factory can be registered to TCO Certified Portal.

Factories will receive a better risk category categorization if they:

- are situated in lower risk countries;
- are involved in a social conformity certification and surveillance system that requires a minimum level of conformity before approval;
- have proven a high level of progress in non-conformity closure meaning that all non-minor non-conformities are closed;
- providing proof of well-functioning dialogue between the factory management and a democratically elected trade union or worker representatives. See clarification section: Qualification method and assessment of worker management dialogue.

Lower risk countries

Some countries are considered as lower risk of social non-conformities by the SA8000 Country Risk Assessments Process, which is based on World Governance Indicators (WGI). These countries include but are not limited to: EU countries, USA and Japan. [A full list is available here: Country risk level is a factor that is considered when setting category levels 2 and 3.](#)

TCO Certified Accepted Factory List

All brand owners, applicants and verifiers who have access to TCO Certified Portal will have access to see TCO Certified Accepted Factory List: [of registered factories](#). This list includes information such as the risk category, ~~a list of~~ audit non-conformities and due dates for submitting supporting documentation. ~~The~~ Access to information for factories ~~which are~~ directly owned by a brand owner, is limited to that brand owner. ~~This is an advantage for those factories that work proactively with sustainability issues, closing non-conformities and monitoring continued conformity. These factories will be considered a better choice to do business with than risk category 1 factories.~~

Audit report and factory Risk categorization procedure.

Initial audits are required ~~regularly~~ [at regular intervals](#). The audit interval is based on the factory risk category.

- An **initial audit** ~~is covering~~ [covers](#) the ~~full scope of the whole~~ factory and this criterion.
- A **closure audit** covers at least the open non-conformities from the latest initial audit.
- An initial audit is more comprehensive and is accepted as a closure audit.
- Audits older than 12 months are not accepted. ~~However, they can be used for the initial risk categorization of new registered factories to TCO Certified Portal.~~

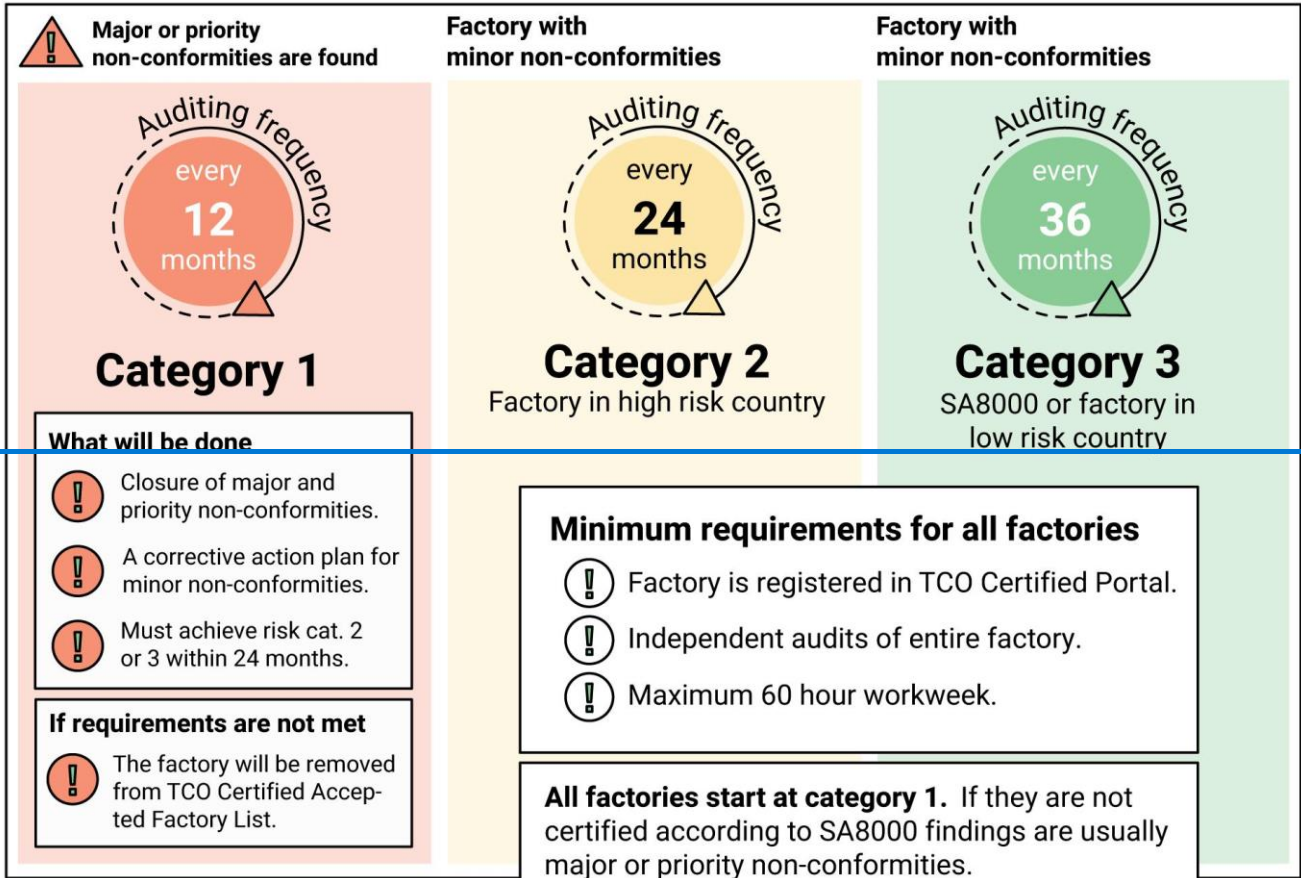

Initial risk categorization

- ~~For Risk category 1 is given to~~ all new factories ~~on entering~~ TCO Certified Portal, ~~existing independent audits that are less than 36 months old must be uploaded to TCO Certified Portal for risk categorization. If no such audit exists, then the factory will be classified~~ Accepted Factory List. ~~Factories cannot continue~~ as risk category 1 by default.
- ~~Risk category 1~~ for more than 18 months or return to category 1 once they have been category 2 or 3.

Risk category 1 (higher risk choice).

Initial audit

- ~~For~~ Only risk category 1, ~~the factory must be audited every~~ factories receive up to 18 months to achieve risk category 2 or 3. Only initial audits less than 12 months and a new initial audit must be uploaded to old from the date the factory is registered on TCO Certified Portal during these 12 months. The start and end date of a new period is always on the date when the factory was first registered are accepted. Any priority and major non-conformities to TCO Certified must be independently verified closed with a closure audit within the time period specified in the table below. The due date for achieving category 2 or 3 appears on TCO Certified Portal for each active factory.

Audit status on initial factory registration date	Priority and/or Major non-compliances	Months to achieve category 2 or 3
Without an initial or closure audit.	Unknown	18 months to conduct an initial and closure audit
With an initial audit report less than 6 months old	Yes	12 months to conduct a closure audit
With an initial audit report less than 12 months old	Yes	6 months to conduct a closure audit

Corrective action plan

- ~~When an audit has been uploaded it often includes some non-conformities.~~ For each non-conformity to the mandate ~~in TCO Certified~~ commitment, a corrective action plan

must be uploaded to TCO Certified Portal. It must include closure deadlines, set by the audit program, ~~for the completion of~~ to complete each corrective action.

Closure audit

- If there are major or priority non-conformities in the initial audit, a closure audit must be submitted within ~~12 months of the~~ the remaining time (see table above). The due date for the factory was registered to closure audit appears on TCO Certified Portal. ~~For minor non-conformities,~~ The corrective action plan must be completed for minor non-conformities, but it is not necessary to submit the closure audit.

Re-categorization

- When all non-conformities other than minor are closed, the factory will be categorized as risk category 2. If the factory is also placed in a lower-risk country, ~~or if it is~~ certified according to SA8000, it will be categorized as 3 instead of 2.
- ~~Otherwise the factory will continue to be categorized as risk category 1.~~

Final assistance

- If the factory has been categorized as a risk category 1 for 2418 months, then the factory management will may receive final assistance toward conformity through TCO Certified Active Monitoring Program ~~on tco certified.com.~~ If the brand owner or factory decides ~~to not~~ to commit to the active monitoring program, the factory will be removed from TCO Certified Accepted Factory List, and the factory will no longer be allowed to manufacture products certified to TCO Certified.

Risk category 2 (moderate risk choice).

Initial audit

- For risk category 2, the factory must be audited every 24 months ~~and~~. A new initial audit report must be uploaded to TCO Certified Portal during the ~~first 12 months of every 24-month~~ audit period, and all major and priority findings must be independently verified closed within this time. The ~~start and end~~ due date ~~of a new period for submitting audit proof to retain a place on TCO Certified Accepted Factory List~~ is always on the date when the factory was first registered to shown on TCO Certified Portal.

Corrective action plan

- ~~When an audit has been uploaded it often includes some non-conformities.~~ For each non-conformity to the mandate in TCO Certified, a corrective action plan must be

uploaded to TCO Certified Portal. It must include closure deadlines, set by the audit program, ~~for the completion of~~ to complete each corrective action.

Closure audit

- If there are major or priority non-conformities, a closure audit must also be uploaded to TCO Certified Portal during the first 12 months of every 24-month audit period. If the factory only has minor non-conformities, the corrective action plan must be completed, but it is not necessary to upload the closure audit to TCO Certified Portal. The closure of minor non-conformities will be verified in the next initial audit.

ATTENTION

~~It is recommended to conduct the initial audit early in the first 12 month audit period, to have time to also provide the closure audit during the first 12 months. If the closure audit is provided later than 12 months after the start of the audit period, the factory may be re-categorized. This may happen even if the audit closure deadline in the corrective action plan allows for more time to close the non-conformities.~~

Re-categorization

- ~~As long as all non-conformities other than minor are closed within the time specified in the corrective action plan, the factory will continue to be categorized as risk category 2. If it is certified according to SA8000, it will be categorized as risk category 3 instead of 2.~~
- ~~Otherwise, the factory will be categorized as risk category 1.~~

Conformity option: ~~As proof of conformity to risk category 2 without the need to upload a closure audit report to TCO Certified Portal, factories that can prove they have received the status of Platinum, Gold or Silver under the RBA recognition program and provide additional proof that working hours are under 60 hours per workweek will be categorized risk category 2, or 3 if the factory is placed in a lower risk country. Silver level is only accepted if there are no major non-conformities to this criterion.~~

Risk category 3

The initial audit should be conducted at least 6 months before the factory audit due date on TCO Certified Portal to give time for a closure audit (if one is necessary).

Failure to retain category 2

- Failure of the factory to retain category 2 within the due date will cause it to be flagged on TCO Certified Portal, which means no certification applications for products manufactured at the factory are approved until the remaining non-compliances are closed. Additional time to close remaining non-compliances may be applied following a risk assessment of the reasons behind the failure to close the non-compliances on time and the closure time plan submitted by the factory. If the brand owner or factory decides not to commit to retaining category 2, the factory will be removed from TCO Certified Accepted Factory List, and the factory will no longer be allowed to manufacture products certified to TCO Certified.

Risk category 3 (lower risk choice).

Initial audit

- For risk category 3, the factory must be audited every 36 months ~~and~~. A new initial audit must be uploaded to the TCO Certified Portal during the first 12 months of every 36-month audit period, and all major and priority findings must be independently verified closed within this time. The ~~start and end~~ date ~~of a new period for submitting audit proof to retain a place on TCO Certified Accepted Factory List~~ is always on the date when the factory was first registered to shown on TCO Certified Portal.

Corrective action plan

- ~~When an audit has been uploaded it often includes some non-conformities.~~ For each non-conformity to the mandate in TCO Certified, a corrective action plan must be uploaded to TCO Certified Portal. It must include closure deadlines; set by the audit program, ~~for the completion of~~ to complete each corrective action.
 - If the factory is SA8000 certified, then the non-conformities are solved ~~in accordance with~~ following the SA8000 certification procedure.

Closure audit

- If there are major or priority non-conformities, a closure audit must also be uploaded to TCO Certified Portal during the first 12 months of every 36-month audit period. If the factory only has minor non-conformities, the corrective action plan must be completed, but ~~it is not necessary to upload~~ uploading the closure audit to TCO

Certified Portal [is not required](#). The closure of minor non-conformities will be verified in the next initial audit.

- A valid SA8000 certificate is considered proof that major and priority non-conformities are [being monitored during regular intervals regularly](#) by SAAS-accredited verifiers; and that issues are being solved.

Re-categorization

- ~~Factories certified according to SA8000 are categorized as risk category 3. If it is discovered that non-conformities other than minor still occur, the factory will [The initial audit should](#) be categorized as risk category 1.~~
- ~~Factories that are not SA8000 certified but are situated in lower risk countries and have provided a satisfactory closure of all non-minor non-conformities within the first 12 [conducted at least 6](#) months of the audit period can achieve risk category 3 status.~~
- ~~Factories of risk category 2 can apply for re-categorization to risk category 3 by providing proof of well-functioning dialogue between the factory management and a democratically elected trade union or worker representatives. See the qualification method below.~~

Qualification method and assessment of worker-management dialogue

~~For factories at risk category 1 it is very likely that the worker-management dialogue is not mature enough due to the number of persistent non-conformities. However, once a factory has managed to solve their major and priority non-conformities and achieved risk category 2, they may apply for risk category 3 re-categorization based on worker management dialogue. To qualify for re-categorization to risk category 3 all the below verification points for a Trade union or non-union worker representation must be considered compliant without remarks.~~

Verification of the level of worker/management dialogue at the factory.

~~In order for a factory to be able to get re-categorization from risk category 2 to 3 based on the worker management dialogue, the factory management, and worker representatives must together prove the following. The proof must be assessed [during before](#) the factory audit [every 3 years](#) by an independent auditor approved by TCO Development. To become approved the auditor evaluating worker management dialogue must fulfill all the requirements of auditors in [due date on](#) TCO Certified and must also have documented experience and deep understanding of trade union work.~~

In the case of a Trade union (TU)

Criteria for assessing a Trade union (TU) presence at factories in high-risk countries for consideration for TCO Certified risk category 3 status:

Requirements on the trade union

- 1.—The TU is not in any way interfered with or financed by the factory management and is independent from the local and national government.
- 2.—The TU is financed by membership fees or donations from non-profit organisations and is non-profit
- 3.—The TU has bargaining rights and acts on the behalf of employees in collective bargaining negotiations with employers.
- 4.—The TU should set and fulfill some or all of the goals it sets itself to win concessions for workers, such as: improve working conditions, working hours, wages and benefits

Requirements on the management

- 5.—Factory management contributions are limited to providing meeting space/materials
- 6.—Payroll records etc show TU employees are not discriminated if they also work at the factory
- 7.—No management interference with the TU representative meeting new consenting employees to explain their rights to freely join the TU and membership is open to all employees.
- 8.—The TU has the ability to call a strike, without restriction from government or company management.

Requirements on the worker—management dialogue

- 9.—TU meets with management regularly for the purpose of furthering and defending the rights and interests of workers for mutual gains. TU meeting minutes and financial records are kept and made available.
- 10.—TU representatives have access to
 - a.—Risk assessments
 - b.—Internal audits and monitoring of the organization
 - c.—Relevant and appropriate aspects of management review
 - d.—Opening and closing meetings of labor audits
 - e.—Reporting back to workers on any corrective and preventive actions takenReporting back to Senior Management on the performance and benefits of actions taken to meet the criteria in the [Portal to give time for a closure audit \(if one is necessary\)](#).

In case of a non-union worker representation

If the above union criteria are not possible to fulfill due to country laws restricting freedom of association and collective bargaining, workers shall be allowed to freely elect their own non-union representatives. (Note: worker representation should not be seen as a substitution for a union representative in organizations where workers freely choose to organize.)

An organised committee of democratically elected worker representatives from non-management personnel is defined as a democratic trade union like system and must meet the following criteria:

- 1.—An organised committee consists of democratically elected representatives from non-management personnel and is independent from the local and national government.
- 2.—The number of representatives shall be in proportion to the number of workers at the factory and must be in the range 1 for every 50-100 workers.
- 3.—The worker committee has the right to represent the workers in collective negotiations with management.
- 4.—The committee has set and fulfills some or all of the goals it sets itself to win concessions for workers, such as: improve working conditions, working hours, wages and benefits.

Requirements on the management

- 5.—Management has not intervened or interfered in any way in the nomination, election, operation, administration of the committee.
- 6.—Payroll records etc show worker representatives are not discriminated against if they also work at the factory. Workers representatives must be allowed to carry out their duties in the organized worker committee during normal working hours without any wage deductions.
- 7.—The worker committee is free to fulfill their goals without being subjected to discrimination, harassment, intimidation, or retaliation for being representative(s) of workers or engaged in organizing workers, and that all workers have access to the representatives in the workplace and access to their services.
- 8.—Worker representatives have the possibility to meet all new consenting employees to explain their labor rights.
- 9.—Committee members shall be allowed to attend relevant committee training during normal working hours without getting wage deductions to help fulfill their duties
- 10.—Factory management must provide meeting space/materials

Requirements on the worker—management dialogue

- ~~11. Committee meets with management regularly for the purpose of furthering and defending the rights and interests of workers for mutual gains. Meeting minutes and financial records are kept and made available.~~
- ~~12. The non-union committee have access to
 - a.—Risk assessments
 - b.—Internal audits and monitoring of the organization
 - c.—Relevant and appropriate aspects of management review
 - d.—Opening and closing meetings of labor audits, includes RBA and SA8000 audits
 - e.—Reporting back to workers on any corrective and preventive actions taken~~

Reporting back to Senior Management on the performance and benefits of actions taken to meet the SA8000 Standard.

Additional clarifications that are valid for all risk categories

- If the audit program and lead auditor accepts an offsite closure audit it will also be accepted in TCO Certified.
- If proven conditions change, such as when non-conformities are found during a spot check, the risk categorization will be re-assessed.
- A major non-compliance given to a control point in the audit report for the only reason that working hours do not meet the stricter local legislated levels than the 60 hour workweek permitted in TCO Certified; may have this rating altered to compliance on TCO Certified Portal on condition that the 60 hour working week requirement is met.
- Closure of priority findings within the CAP deadline will be monitored ~~in particular~~ by TCO Development through the spot check program.

Spot checks of supply chain responsibility

~~Spot checks are financed by TCO Development as long as no non-conformities are found. If non-conformities are found and further investigations are necessary, the cost for this must be covered by the license holder.~~

Audit reports and corrective action plans

~~Central to the spot check conformity program is the review of the factory audit report and corrective action plan conducted by a verifier approved by TCO Development. TCO Development will randomly select audit reports and corrective action plans on TCO Certified Portal to be spot checked. This is to ensure that the data uploaded to TCO Certified Portal is correct.~~

During the spot check conformity program, the corrective action plan will also be evaluated for effectiveness by the approved verifier. A judgement on the remedial effectiveness and a summary will be given in the verification report issued by the approved verifier. This summary is permitted to be shared with the clients of the factory.

On-site inspection initiated by TCO Development

On-site factory inspection initiated by TCO Development (spot checks).

TCO Development reserves the right to require full audit reports and conduct or commission on-site inspections at final assembly factories registered on TCO Certified Portal as manufacturing the certified product; to verify that the brand owner is fulfilling the monitor continued compliance to obligations in this criterion. The planning of social audits will be done in cooperation with the Senior Management Representatives appointed by the brand owner, accepted social auditors and factory management. Factory audits are announced up to two weeks in advance.

Social audits initiated by TCO Development will be realized on a judgement sample basis, in each case decided upon and financed by TCO Development. Results from the audits Audit results will be shared with the audited factory (both management and worker representatives) and all the brand owners listed as using the audited factory. This is in order to create a combined combine the effort toward implementing the corrective action plan. For TCO Development, the spot checks and all other uploaded reports contain valuable information on social performance, making it possible to translate close any non-compliance. Spot check audits are financed by TCO Development. If priority non-conformities into metrics and then measure improvements through code of conduct and audit methodology are found and further investigations are necessary, the license holder must cover this cost.

The verifier approved for supply chain responsibility

Only an independent verifier approved by TCO Development has the authority to approve the following:

For each brand owner:

- Code of conduct.
- Communication of the code of conduct.
- Supporting documentation.
- Conduct interviews reviews with a senior management representative.

Other assessments

- Review evidence that could prove that another audit protocol can be considered “equal quality to other approved audit protocols”. This includes but is not limited to; auditor qualification, audit process, reporting and corrective action plan.

The list of approved verifiers is found at tcocertified.com.

Draft 2

2.2 Supply chain transparency

Background

Supply chain transparency includes two vital parts: a) the extent to which information about a company and its sourcing locations is made public to end-users and stakeholders and b) the company's process of taking action through supply chain visibility; to manage it effectively.

Companies struggle to achieve supply chain transparency since they lack a solid process and structure to manage risks and monitor behavior in their extended supplier network. Without visibility into their supply chains, brand owners create a blind spot where damage to reputation can emerge.

Transparency toward an independent party provides a company not only with the possibility to measure its own performance in key areas against [their/its](#) peers; but also a way to share and gain knowledge about solutions. Supply chain transparency requires a solid management system, where improvements are achieved by acting on responses to shared information.

Applicability

All product categories.

2.2.1 Mandate

The brand owner must appoint a Senior Management Representative (SMR) for supply chain responsibility for the certified product, who reports directly to senior management.

Irrespective of other duties, this person must have the authority to ensure that the certified product meets the supply chain criteria in TCO Certified.

The SMR ~~must annually complete~~ [has access to TCO Development's self-assessment questionnaire \(SAQ\) Certified Portal](#) and ~~complete a follow up interview~~ [must ensure that the due dates for submitting supporting documentation are complied with](#).

[The SMR is responsible for the brand owner annual review process being completed with](#) an approved verifier-, [and the report is uploaded to TCO Certified Portal before the annual due date.](#)

Submit the following to an approved verifier:

[Once a year at the Senior Management Representative interview:](#)

- A completed [and signed self assessment questionnaire \(SAQ\) annual review report.](#)
- A completed and signed brand owner form covering [the/all](#) certified [product/products and brand names used](#) (chapter 11.1)

Submit The following ~~together with the application~~ is submitted to TCO

Development:

- The report from the annual review must be uploaded to TCO Certified Portal.
- A copy of a verification report from a verifier approved by TCO Development.

The report from following is submitted to TCO Development and may be published:

- The status (Yes/No & link to public list), if all final assembly factories manufacturing the SMR interview including certified product are listed publicly by the verified self-assessment questionnaire (SAQ)-brand owner.

2.2.2 Clarifications

General clarifications

The aim of the mandate is to create transparency between TCO Development and senior management at the brand owner company of the certified product.

Senior Management Representative (SMR) details

The required details of the SMR must appear in TCO Certified Portal, and the SMR must be available for dialogue in English with TCO Development and verifiers throughout the validity of all the brand owner's certificates.

If the appointed SMR is changed, then details of the new SMR must be updated in TCO Certified Portal. TCO Development must be informed immediately.

The SMR must ensure that TCO Certified Portal is up to date, covering [the following](#):

- Name, title, telephone number and email address of the SMR.
- ~~A date, with a period of less than 12 months, of the completed and / or planned SMR interview with the name of the approved verifier.~~

SMR interview

- [A valid annual review report.](#)

SMR and annual review

The ~~interview with the SMR~~[annual review](#) must be done with one of the verifiers approved by TCO Development. It is booked and paid for by the SMR [company](#). The purpose is to ensure that the appointed person has the necessary authority and ~~is working that the company works~~ in a structured way to implement the ~~brand owner's code of conduct~~. ~~Primarily, the interview will cover points covered in the~~ [self-assessment annual review](#) questionnaire ~~(SAQ) answers about supply chain management.~~

~~If the brand owner has more than one brand name registered, the review must cover each brand name respectively and ensure that all requirements in TCO Certified are fulfilled. The verifier must ensure that it is intuitive for anyone searching for the required information on each brand name's website where to find the information. In some cases, this means that it must be publicly stated who owns the brand name or that links are provided to the documents on the brand owner's website.~~

~~As part of the annual review process,~~ all questions ~~in the SAQ~~ must be answered and submitted to the verifier ~~prior to before~~ the interview. During the part of the ~~interview~~[review questionnaire](#) that covers the ~~SAQ~~[section on social performance](#), the SMR will be required to

explain ~~in more detail~~ the brand owner's work toward a socially responsible supply chain of the certified product and provide supporting documentation where needed. It is recommended that SMRs involve colleagues in the meeting who can provide ~~the~~ necessary expertise in the areas covered by the ~~SAQ questions~~.

The interview ~~part of the review process~~ will likely be an online meeting. If ~~for some reason~~ it is not possible to have an online meeting or ~~if~~ the interview does not obtain an acceptable quality due to language difficulties, then the verifier may require a face ~~to face interview to-~~ ~~face interview~~. ~~TCO Development has the right to participate in the interview with the SMR. In this case, TCO Development will cover its own expenses.~~

The ~~final~~ report from ~~this interview the annual review~~ is then uploaded to TCO Certified Portal. ~~TCO Development have the right by the verifier.~~

~~The annual review questionnaire is revised every third year, following the launch of a new generation of TCO Certified.~~

~~An evaluation is made based on the review results regarding the voluntary public disclosure of final assembly factories. There is no mandatory level, but this information may be shared with purchasers.~~

~~The link to participate the brand's publicly disclosed factories (if available) is taken from the review results and entered into TCO Certified Portal. After the report is uploaded, the verifier cross-checks the publicly disclosed factories at the interview with the SMR. In this case TCO Development will cover their own expenses provided link against the final assembly factories used by the brand to manufacture certified products in TCO Certified Portal.~~

~~To count a final assembly factory as publicly listed, it must be made public on the brand owner website and state that the brand owner has a business relationship with those factories. The factory information must show at least the supplier name, factory full address and type of products manufactured at the factory.~~

About the ~~self-assessment annual review~~ questionnaire (SAQ) and result benchmarking

The ~~SAQ annual review questionnaire~~ is ~~a set an independent assessment~~ of ~~questions aimed at gaining transparency into~~ the brand owner's risk management ~~in of~~ the supply chain of the certified product. ~~This includes areas such as child labor, worker representation, unions, ethics and minerals~~ and is part of TCO Development's capacity-building work with brand owners.

The SMR is responsible for answering all questions and providing supporting documentation where needed. ~~The SMR must follow the SAQ guidelines when answering. Each answer must be given according to the following three levels of commitment that can be proven. Answers are color verified and the level of achievement is benchmarked for easy reference: invested (green), involved (yellow) or interested (red) by the verifier.~~

~~There is no minimum graded level required to be fulfilled, since the SAQ is only~~For the annual SMR interview questionnaire is intended to gather information on the actual level of social commitment, ~~identify capacity-building possibilities, share solutions,~~ and assist in ~~the development of~~developing future generations of TCO-certified criteria. Feedback to the brand owner is given in the form of a report and table ~~that shows~~showing the brand owner's final grading (after the interview) ~~in comparison~~compared to other certifying brand owners (all brand names ~~will remain~~are kept anonymous). This ~~will help~~helps the brand owner identify areas for improvement and measure their progress within the industry.

Result data will also be used to risk assess factories of the certified product for the spot-check program. In this program, TCO Development orders annual factory audits according to the code of conduct by independent auditors at a number of final assembly factories where certified products are manufactured.

The [annual review](#) questionnaire and guidelines for the ~~assessment~~[annual review process](#) are public and available for download at tcocertified.com:

Clarification of sustainability performance indicator(s)

One or more "sustainability performance indicators" (chapter 1.3) are collected for this criterion. There is no mandatory level for these indicators but they must be verified and reported according to the description below:

- **Public factory list**

The percentage of final assembly factories manufacturing certified products which are publically listed on the brand owners website must be reported in TCO Certified Portal, annually. (0% may be reported if the number is unknown):

In order to count a final assembly factory as publicly listed it must be made public on the brand owner website under a heading "Supply Chain" or similar. The factory information must show at least the supplier name, factory full address and type of products produced at the factory. Additional information on whether the supplier has produced a GRI based sustainability report is optional.

2.3 Anti-bribery management system

Background

Bribery is a widespread phenomenon. It raises serious moral, economic and political concerns, undermines good governance, hinders development and distorts competition. It erodes justice, undermines human rights, and ~~is an obstacle to the relief of~~[hinders](#) poverty [relief](#). It also increases the cost of doing business, introduces uncertainties ~~into~~[in](#) commercial transactions, increases the cost of goods and services, diminishes the quality of products and services, which may lead to loss of life and property, destroys trust in institutions and interferes with the fair and efficient operation of markets.

Organizations ~~have a responsibility to prevent~~[are responsible for preventing](#) all forms of corruption within their businesses and ~~their~~ supply chains. To do so, organizations must align their business policy, monitoring and enforcement mechanisms with internationally recognized best practices against all forms of bribery.

With TCO Certified, brand owners that apply for product certification are ~~interviewed~~[reviewed](#) by an independent reviewer, who assesses the brand owner's anti-bribery management system; to ensure that it meets the requirements of ISO 37001.

Applicability

All product categories.

References

2.4.

2.3.1 Mandate

The brand owner must have internal processes and routines in place to prevent and respond to all forms of bribery, covering all business activities connected to the certified product. This includes ~~making sure~~[ensuring](#) that the supply chain ~~proves alignment of at least the certified~~[product aligns](#) with the anti-bribery management system standard ISO 37001.

Submit the following to an approved verifier:

- A completed and signed brand owner form covering the certified product (chapter 11.1).

- An ISO 37001 certificate, ~~or a booked date for the self-assessment questionnaire (SAQ) and follow-up interview with~~ [or the anti-bribery review report by](#) an approved verifier.

Submit The following ~~together with the application is submitted~~ to TCO

Development:

- A copy of a verification report from a verifier approved by TCO Development.
-

Draft 2

2.3.2 Clarification

The brand owner's anti-bribery management system covering all business activities connected to the certified product, including the supply chain, must be considered to be aligned with ISO 37001. If an ISO 37001 certificate is ~~not available~~unavailable as proof, the brand owner ~~has the option to can~~ complete the self assessment questionnaire (SAQ) and take part in a follow-up verification interviewreview with an approved verifier. ~~A date for the interview must be set before the verifier can issue a verification report to TCO Development.~~

A follow-up review of the brand owner anti-bribery management system will be in the form of a ~~self assessment~~ questionnaire (SAQ) and included in the first interviewannual review with the assigned Senior Management Representative (SMR) for supply chain responsibility.

Each answer ~~of to~~ the SAQquestionnaire will be graded using ~~a color~~. Green is passaligned, yellow is room for improvementpartial alignment and red is ~~non-compliance~~no alignment. A completed SAQquestionnaire and ~~required~~ supporting documentation must be submitted to the verifier ~~prior to~~before the interviewreview. These will be verified in the online interviewreview between the verifier and the brand owner SMR and any experts responsible for anti-bribery the SMR wishes to include.

Verification guidelines

- ~~If~~Alignment to ISO 37001 without providing a valid certificate is when all answers are scored green (except 12.1) in the first anti-bribery section of the annual interview, ~~then there's~~review questionnaire. When all required points are aligned, there is no need to include ~~the~~ anti-bribery interview in the following annual ~~eyele~~reviews unless requested by TCO Development.
- ~~If any point is yellow (except 12.1), only these need to be covered in the following annual interview, to check if the brand owner has improved to green level.~~
- ~~If any point~~ is scored yellow or red, a corrective action plan must be submittedmade, and the point will be included in the following annual interviewreview and must ~~then be~~ either yellow orscored green.
- Only question 12.1 (covering independent verification of the anti-bribery management system) can be graded yellow or red ~~indefinitely~~, since ~~the interview~~this review in TCO Certified is considered an independent verification of the anti-bribery management system.

2.4 ~~Responsibly sourced minerals~~ Responsible mineral sourcing

Background

Minerals such as tin, tantalum, tungsten, gold and cobalt are connected to armed conflicts and human rights abuses in the ~~world's~~ regions ~~of the world~~ where they are extracted. Unsafe mining methods also lead to severe health problems for workers, and environmental degradation in local communities. Since the mineral supply chain can include hundreds of suppliers, from mines and smelters ~~or refiners~~ to final production, ~~it is a challenge to~~ making informed choices about mineral sourcing, from extraction to finished product, ~~is~~ challenging.

TCO Certified drives more responsible mineral sourcing in all countries where the mining industry and trade are present. Suppliers must adopt a responsible approach to mineral sourcing, irrespective of where ~~in the world~~ they operate. TCO Certified goes beyond the current definition of conflict minerals and requires ~~that~~ brand owners ~~to~~ include cobalt ~~as part of~~ in their due diligence process. To drive widespread, positive impacts ~~at a faster rate~~, due diligence and risk reporting ~~is~~ are standardized, ~~with focus~~ focusing on long-term, continuous improvement.

Applicability

All product categories.

References

2.5, 2.6, 2.7, 2.8.

2.4.1 Mandate

The brand owner must:

- Have a ~~strict~~ supply chain policy for responsible ~~minerals~~ mineral sourcing; for the certified product that can be considered to cover at least 3TG and cobalt. The policy must be both public and communicated to the supply chain.
- ~~Have~~ Conduct a ~~process to identify reasonable country of origin inquiry for~~ smelters ~~and/or~~ refiners (SORs) of at least 3TG and cobalt for the certified product ~~that follows the OECD Due Diligence Guidance for Responsible Supply Chains of Minerals from Conflict-Affected and High-Risk Areas process~~.

- [Annually demonstrate that at least 70% of the total number of SORs for 3TG and cobalt in the supply chain of the certified product are conformant \(certified\) to an accepted independent third party due diligence program.](#)
- Annually submit the completed [responsibly sourced minerals/responsible mineral sourcing template with all the information required in the](#) template.

Submit the following to an approved verifier:

- The most recent version of the public responsibly sourced minerals policy and a description of how it is communicated to the supply chain of the certified product.
- A description of the brand owner’s structured work on identifying risk areas in the supply chain of the certified product with supporting documentation.
- The [responsibly sourced minerals/responsible mineral sourcing](#) template ([a TCO Certified template](#)) and [supporting documents](#) must be completed and submitted to TCO Certified Portal before the brand owner annual due date stated [on the portal in TCO Certified Portal and cover the supply chains of the final assembly factories of the certified product registered by the brand owner on TCO Certified Accepted Factory List](#).
- A completed and signed brand owner form covering the certified product (chapter 11.1).

Submit The following ~~together with the application~~ is submitted to TCO

Development:

- A copy of a verification report from a verifier approved by TCO Development.
- A copy of the responsibly sourced minerals policy, in English. (Must be uploaded to TCO Certified Portal.)

2.4.2 Clarifications

Responsibly sourced minerals policy

The responsibly sourced minerals policy is an essential statement by the brand owner. It ~~reflects~~[must reflect](#) the brand owner’s commitment toward responsible sourcing of minerals and the expectations that their raw material suppliers adhere to the policy.

Verification guidelines:

The verifier must ~~be able to~~ verify that the responsibly sourced minerals policy can be considered to cover at least 3TG and cobalt for [all](#) the certified ~~product~~[products, that it](#) is public, and ~~also~~ that it is clear how the policy [is](#) communicated to suppliers.

- “Public” means that the policy is visible on the brand ~~owner~~owner's website; or is included in the brand owner’s annual sustainability or responsible minerals report, and that it is communicated that it covers all the brand names the brand owner has registered on the TCO Certified Portal.
- “Communicated” could be ~~as~~ part of a contract and/or ~~in~~ a written agreement with suppliers.

To verify the level of strictness, the policy must require at least the following:

- That suppliers ~~conform with~~uphold the policy.
- That suppliers neither directly nor indirectly finance armed groups in conflict-affected regions.
- That suppliers neither tolerate nor contribute to human rights abuses that include forced labor, child labor and environmental degradation.
- A commitment to supporting responsible sourcing from ~~those~~ regions ~~in which~~where specific mining operations may present risk.
- Suppliers work with the brand owner to identify SORs of 3TG and cobalt in the supply chain and report details using a conflict minerals reporting template (CMRT) or extended minerals reporting template (EMRT).
- That sourcing of 3TG and cobalt must be from SORs participating in third party audit programs aligned with OECD Due Diligence guidance and working toward certification.
- That action plans must be developed for SORs identified as not participating or certified to a third party audit program to remove them from the supply chain or have them participate in a program to obtain certification.

Structured work on identifying risk areas

The brand owner must carry out structured work to identify if at least 3TG and cobalt are present anywhere in the supply chain of the certified product, with the goal to identify the ~~smelters and refiners~~SORs. The verification of the structured work is carried out as part of the brand owner annual review process.

Identifying risk areas is a process that helps map the chain of custody of risk minerals down to the ~~smelters and refiners~~SORs within the supply chain. This is commonly done by a minerals ~~reporting template such as a conflict minerals reporting template and a cobalt~~ reporting template being systematically sent through the supply chain. This transfer of information facilitates the identification of high-risk ~~smelters and refiners~~SORs.

Verification guidelines:

The verifier has been provided [with](#) a description of how the brand owner identifies risk areas in ~~its~~[the](#) supply chain of the certified product. The verifier can also require a copy of the completed [minerals reporting](#) template as further evidence of compliance. See ~~below~~[the](#) examples [below](#):

- Using an established ~~conflict~~[conflict](#) minerals reporting template as part of the brand owner's due diligence process. As a random follow-up at the request of TCO Development, completed examples of the template are to be submitted to the verifier.
- A public list of ~~smelters and refiners~~[SQRs](#) on the brand owner website ~~is considered~~[verification verifies](#) that the brand owner has identified the list ~~through~~ using a minerals reporting template.

Regulated ~~Audited~~ smelters and/or refiners (SQRs)

Brand owners are required to annually submit information ~~of~~[on](#) the ~~smelter and refiner facilities~~[SQRs](#) identified as the source of 3TG and cobalt in the supply chain of the certified product. The required information identifies ~~those facilities~~[SQRs](#) that are conformant, active or otherwise registered through independent verification for their mineral sourcing due - diligence process.

[The brand owner must annually demonstrate the SQRs that are conformant \(certified\) to an accepted responsible sourcing program and those that are considered to process scrap or recycled materials.](#)

Verification guidelines:

The verifier ~~is~~[must annually be](#) provided with the ~~responsibly sourced minerals~~[responsible mineral sourcing](#) template ([a TCO Certified template](#)) with the required columns covering information on the ~~identified smelters and refiners~~[SQRs](#) identified as the source of 3TG and cobalt in the supply chains of the certified products.

~~The template section; 'Regulated facilities' requires that the brand owner is transparent about which 3TG and cobalt smelter and refiner facilities are conformant or active with RMAP or registered on the EU 'white list'.~~

~~For the template section 'facility details', the brand owner has the option to add a link for their public report that covers 3TG, Cobalt and the 'required' information. If there is no public report or only some of the minerals are covered in the report, then the brand owner must complete the template with the additional required information that is not found in their public report.~~

[More](#)

[The template section, 'Audited facilities' requires information about which SORs are in the supply chain of the certified product. SORs must be publicly registered as conformant with the Responsible Minerals Assurance Process \(RMAP\) or on the European Union \(EU\) 'white list'. Registered as 'active' or 'in-process' is not accepted as compliant. The verifier will compare the submitted information against the latest published list of conformant SORs using the comparison tool provided by TCO Development.](#)

[The brand owner can find their annual due date for submitting the responsible mineral sourcing template on TCO Certified Portal. The template is downloaded from \[tcocertified.com\]\(https://tcocertified.com\) and must be submitted to the accepted verifier in time.](#)

[Audit program cross-recognition](#)

[RMAP cross-recognised audit programs are accepted. These presently include the London Bullion Market Association \(LBMA\) and the Responsible Jewellery Council \(RJC\). Other programs must first undergo independent verification to access the OECD due diligence guidance implementation before being accepted as an alternative. The brand owner must provide proof of alignment to the accepted verifier for assessment.](#)

[Due diligence program information:](#)

- The OECD Due Diligence Guidance for Responsible Supply Chains of Minerals from Conflict-Affected and High-Risk Areas ([“the \(“OECD due diligence guidance”](#)), available at oecd.org. Brand owners require suppliers to disclose their sourcing origins of ~~conflict~~ minerals ~~by~~ using a questionnaire template such as the Responsible Minerals Initiative (RMI), conflict minerals reporting template (CMRT) or similar ~~in order~~ to prevent the potential use of risk minerals.
- Member of the Responsible Minerals Initiative (RMI). Members contribute to a number of tools and resources, including the conflict minerals reporting template, supporting in-region sourcing schemes and the Responsible Minerals Assurance Process (RMAP).
- Responsible Minerals Assurance Process (RMAP) helps companies make informed choices about responsibly sourced minerals in their supply chains. Independent third-party ~~assessments~~[audits](#) of ~~smelter/refiner~~[SOR](#) management systems and sourcing practices are used to validate conformance with RMAP standards. The assessment employs a risk-based approach to validate ~~smelters'~~[SOR](#) company-level management processes for responsible mineral procurement.

The RMAP standards are developed to meet the ~~requirements of the~~ OECD Due Diligence Guidance requirements, the Regulation (EU) 2017/821 of the European Parliament and the U.S. Dodd-Frank Wall Street Reform and Consumer Protection Act.

- EU 'white list' is a proposed list of ~~smelters and refiners~~ SORs. The regulation (EU) 2017/821 ~~works to promote~~ promotes the responsible sourcing of ~~smelters and refiners~~ SORs of tin, tantalum, tungsten and gold, whether they are based inside the EU or not. This is because EU importers ~~will be required to~~ must identify the ~~smelters and refiners~~ SORs in their supply chains and check whether they have the correct due diligence practices ~~in place~~. Whenever EU importers find ~~smelters and refiners'~~ SOR practices ~~to be~~ insufficient or associated with risks, they ~~will have to~~ must manage and report on this.

To help companies, the European Commission is ~~creating~~ working to create a ~~so-called~~ 'white list' compliant list of global ~~smelters and refiners~~ SORs which source responsibly.

2.5 Process chemicals management

Background

Scientific research shows that workers [that/who](#) come into contact with chemical substances used in the manufacture of IT products are more likely to suffer from cancer, reproductive damage, birth defects and other serious illnesses.

The use of chemicals such as benzene and n-hexane (industrial cleaning solvents), [that/which](#) have well-documented toxic human health effects, have been restricted in some parts of the world, but are often used by the manufacturing industry in developing countries where legislation is weaker, and workers are less protected. These chemicals need to be phased out of production, and not be replaced with equally hazardous substances.

To replace chemicals with safer alternatives, process chemicals and their suitable safer alternatives must be identified and independently assessed by an approved toxicologist. The Personal Protective Equipment (PPE), training and exposure monitoring provided to the workers who risk chemical exposure also [needs/need](#) to be reviewed and improved.

Applicability

All product categories.

References

2.9, 2.10

2.5.1 Mandate

Each final assembly factory [and factory](#) manufacturing [display panels >10" for](#) the certified product:

- must have a structured health and safety management system [in place, that is](#) independently certified to ISO 45001.
- [must only use cleaning solvents necessary](#) for product [components](#) and PCB process cleaning that contain individual chemicals or [mixtures/formulations](#) that appear on ~~the~~ TCO Certified Accepted Substance List [for process chemicals](#).
- [must submit chemical inventory data covering at least cleaners, adhesives and lubricants](#).
- All substances of a mixture must be accounted for. Non-accepted substances must not exceed concentration levels of 0.1% by weight of the chemical product.

Submit the following to an approved verifier:

- A copy of the [valid](#) ISO 45001 certificate ~~for each final assembly factory manufacturing the certified product.~~
- ~~A completed Process Chemical Data Collection (PCDC) Tool for each final assembly factory manufacturing the certified product.~~ [An accepted process chemical data collection template.](#) The chemical data must [at least](#) cover [cleaning solvents used for product cleaning](#) [the chemical formulations](#) and [PCB process cleaning at ingredients shown in the chemical safety data sheet and used on](#) the production lines where certified products are manufactured. The ~~scope of chemical data to~~ [template must](#) be submitted [before the factory](#) ~~is stated in the Process Chemical Data Collection (PCDC) Tool, that can be downloaded at [teocertified.com](#) added to TCO Certified Portal.~~
- A completed and signed factory form (chapter 11.2).

Submit The following ~~together with the application~~ **is submitted** to TCO

Development:

- A copy of a verification report from a verifier approved by TCO Development.
- ~~A copy or access to~~ [For assessed substances](#), a copy ~~kept on a database~~ of the ~~complete~~ assessment report ~~conducted and~~ issued by an approved licensed profiler independent of the ~~approved~~ [accepted](#) screened chemistry program. [For GreenScreen certified formulations, a copy of the GreenScreen Certified certificate is acceptable.](#)
- The process chemical data template must be reported in TCO Certified Portal.

2.5.2 Clarification

The [cleaning](#) process chemicals that appear on TCO Certified Accepted Substance List are commonly used by ~~final assembly factories production lines~~ to clean display panels, product enclosures ~~and~~, printed circuit boards (PCBs) ~~and~~, SMT machinery. ~~They have been identified by TCO Development during the previous generation of TCO Certified. PCB cleaners are relevant since many final assembly factories include surface mount technology (SMT) production lines that cover solder machines, stencils, flux, ovens, PCBs, glues and tools.~~

~~These processes~~ [The production lines manufacturing certified products](#) must only use cleaners ~~that are~~ listed on [the](#) TCO Certified Accepted Substance List. To be included on the list, chemicals must be independently assessed; and receive a GreenScreen® benchmark score of 2, 3 or 4. ~~Alternatively or ChemFORWARD hazard band A, B or C. For~~ [chemical mixtures that are formulations](#), GreenScreen certified (~~gold or platinum~~) [or gold set](#) by a licensed GreenScreen Profiler ~~are accepted. Chemicals on the list without an approved~~

benchmark or certification will receive a sunset date for when they will be removed from the list. Before the sunset date, the chemical may be used on production lines where products certified according to TCO Certified are made. This gives the supplier/s time to have an independent assessment of the chemical, or to replace it with an approved benchmarked or certified alternative from the list.

From the date when the factory is registered on the TCO Certified Portal and TCO Certified Accepted Factory List, a factory has up to 12 months to make sure that the cleaning chemicals used on production lines where certified products are made are listed as 12-month transition period to using only safer alternatives appearing on TCO Certified Accepted Substance List:

TCO Development and Clean Production Action (CPA) can be applied for. To keep the factory active on TCO Certified Portal, an updated process chemical data collection template must have access to a copy of the GreenScreen assessment report be re-submitted before the substance can be added to process chemical compliance due date on TCO Certified Accepted Substance List, available at Portal.

Proof of health and safety management system conformity:

The applicant must upload A valid ISO 45001 certificate must be uploaded to TCO Certified Portal for each registered factory that is in scope of this requirement. The certificate must be issued by a certification body that is accredited to issue the certification. Factories that do not yet have a certified health and safety management system according to ISO 45001, may apply to TCO Development for an extended time period of up to 24 months to complete certification by annually submitting an extension. This extended-time application on the status of the certification. This application and status template can be obtained from TCO Development an accepted verifier. TCO Development has the right to deny the applicant an extended period of time if there is reason to believe the factory will not be able to cannot achieve the ISO 45001 certification within the extended time period (for example, if other critical non-compliance issues are pending; or if the time plan is insufficient). A factory that has been certified to OHSAS 18001 has good prerequisites for an extended time approval. a history of persistent audit non-compliance).

Process Chemical Data Collection (PCDC) Tool and Guidelines

The applicant An accepted Process Chemical Data Collection Tool must be completed and upload the PCDC Tool uploaded to TCO Certified Portal. TCO Development has entered the scope of The data to be entered, therefore it is preferred that applicants download

~~#must cover at least cleaning agents, adhesives and lubricants used to produce the certified product. The Process Chemical Data Collection Tool can be downloaded from tcocertified.com/certification-documents.~~

~~For the default PCDC Tool, guidelines and films on how to complete the tool, go to:~~

Completing the Process Chemical Data Collection (PCDC) Tool

- The senior representative at the factory, whose responsibilities cover chemical management, must assist the applicant in [completing the completion of the accepted PCDC Tool](#).
- ~~The areas that must be completed by the applicant are [stated in listed as 'required'](#).~~
- ~~Listed chemical substances must show the Requested Scope tab of the PCDC Tool that can be downloaded from tcocertified.com.~~
- ~~In cases of proprietary, confidential business information of a CAS# number,~~ The chemical supplier can directly submit this information to TCO Development. ~~This must first be agreed upon by the applicant and TCO Development. If this information [if there are proprietary concerns](#). If a CAS# number is [not submitted, then withheld](#), the chemical ingredient [must be](#) treated as a restricted substance, and the cleaning product must be replaced with an accepted alternative. [An alternative is to have the formulation GreenScreen Certified and listed by trade name only](#).~~
- The information must cover [at least all cleaning solvents chemical types required under the mandate](#) and [their chemical ingredients used in the assembly of to manufacture](#) certified products.
- Upon request, the process chemical inventory at the factory must also be submitted for independent verification purposes.
- The PCDC Tool must be updated at the request of TCO Development.
- TCO Development has the right to compile confidential information with CAS numbers. TCO Development reserves the right to publish such compiled, anonymous information, ~~but~~ [Still](#), no information will be presented [in such a way so](#) that the company or the products in question can be identified.

~~To verify compliance with this criterion, the completed PCDC Tool will be reviewed by TCO Development. The factory will be audited by independent assessment bodies.~~

Exposure controls and personal protective equipment (PPE)

TCO Certified Accepted Substance List reduces the risk of worker exposure to highly hazardous chemicals. However, safer alternatives do not remove the responsibility of the factory management to provide personal protection equipment as described in [section 8 of](#)

the ~~chemical~~chemical's safety data sheet (SDS), ~~that~~which covers exposure controls and personal protection. Verification of PPE (availability, training and use) is included in the ISO45001 standard and as part of the required factory ~~audit requirement of audits~~ (see mandate 2.1-).

Draft 2

3 Environmentally responsible manufacturing

- Large amounts of natural resources and energy are used to manufacture IT products.
- This consumption can lead to soil, water and air pollution, as well as large greenhouse gas emissions.
- To reduce environmental risk, the environmental impact must be measured and environmental and energy management systems need to be in place.

Major environmental risks in the IT industry

Several environmental hazards occur throughout the IT product life cycle. The manufacturing process is a large risk. Harmful substances that are not handled safely risk ending up in nature. Life cycle assessments confirm that a typical IT product consumes more energy during its manufacture than during its entire usable life, resulting in large greenhouse gas emissions which impacts our climate. Another risk is the extensive use of natural resources in manufacturing, leading to a high energy consumption and the loss of valuable, finite resources.

Our approach: measuring and incentivizing reduced environmental impact

With TCO Certified, the brand owner must have an environmental management system in place, and work systematically with continuous improvement in environmental performance. Gathering information on material reuse and energy efficiency in the assembly phase is important and creates incentives for reducing the product's carbon footprint.

Criteria in chapter 3 focus on:

- Lowering environmental risk and ensuring continual improvements by requiring that all final assembly factories are certified according to ISO 14001 and have an environmental management system in place.
- Putting the spotlight on energy efficiency in manufacturing through annual reporting.
- Lowering energy use in manufacturing by requiring compliance with ISO 50001.
- Gathering information about post-consumer recycled content and renewable materials to help buyers identify more circular products.
- Offering the brand owner an incentive to determine the product's carbon footprint through Product Carbon Footprint (PCF) analysis.

3.1 Environmental management system

Background

A certified environmental management system helps an organization work in a systematic way with environmental performance, and make continuous environmental improvements. To be efficient, an environmental management system must include independent, external reviews.

Definitions

~~Final assembly factory: A Final assembly factory is where the final assembly of the certified product is taking place and is defined as the whole operation covered by a business license, and thereby the employment agreements of the factory workers.~~

[See definitions chapter 2.0](#)

Applicability

All product categories.

The company or companies that manufacture the product.

References

2.11

3.1.1 Mandate

- Each final assembly factory ~~and each factory~~ manufacturing ~~display panels >10" for~~ the certified product must ~~behave a structured environmental management system that is independently~~ certified ~~in accordance with to~~ ISO 14001.

Submit the following to an approved verifier:

- A copy of a valid ISO 14001 certificate for ~~everyeach~~ final assembly factory ~~and each factory~~ manufacturing ~~panels >10" for the~~ certified ~~productsproduct~~.

~~Submit~~ The following ~~together with the application~~ ~~is submitted~~ to TCO

Development:

- A copy of a verification report from a verifier approved by TCO Development.
-

3.1.2 Clarification

The applicant must ensure that a valid ISO 14001 certificate is available on TCO Certified Portal at all times, for every final assembly factory, [and display panel factory that are registered to TCO Certified Portal as](#) manufacturing certified products.

The certificate(s) or an appendix to the certificate(s) must make it clear what the certification covers.

[If necessary](#) the applicant may ask for an extended time period of [up to](#) 12 months ~~maximum~~ on behalf of a factory that is not yet certified, by presenting a time plan for achieving the ISO 14001 certification and signing an agreement. TCO Development has the right to deny the applicant an extended period of time if there is a substantial risk that the factory will not be able to achieve ISO 14001 certification within the extended time period.

The certificate must be issued by a certification body that is accredited by an accreditation body covered by the International Accreditation Forum, [iaf.nu](#), Multilateral Arrangement on Environmental Management Systems.

3.2 Energy efficiency indicators Renewable energy

Background

While IT products become increasingly energy efficient in the use phase, there are still improvements to be made in the manufacturing phase. Life cycle assessments show that many IT products consume more energy during manufacturing than during the use phase. As we face the challenges posed by climate change, it has become increasingly important for companies to transition to renewable energy sources. By increasing the share of renewable electricity in the final assembly of certified products, the product carbon footprint and climate impact of the certified product are reduced. This also increases the demand for Renewable Energy Certificates (RECs), which increase the economic incentive to build new generators for renewable electricity in many regions where most electricity is generated from non-renewable sources.

Applicability

All product categories.

3.2.1 Mandate

~~Each~~ At least 15% of the electricity used in the final assembly factory which manufactures of the certified product must report the previous calendar year energy efficiency indicators by the end of August each year. (be procured and/or generated from renewable sources. This applies until the year after a certificate has expired.) ratio must be reported yearly.

Submit the following to an approved verifier:

- ~~• A completed and signed factory form(s) (chapter 11.2)~~

~~Submit the~~ Once a year, the brand owner must provide:

- Documented proof of the ratio of renewable electricity used in the final assembly of the certified product in each factory that is used.
- Documented proof of the total electricity and the ratio of renewable electricity used in each final assembly factory of the certified product.

The following together with the application is submitted to TCO Development:

- A copy of the verification report(s) from a verifier approved by TCO Development.

- The energy efficiency indicators The ratio of renewable electricity used in the final assembly of certified products for the brand in each factory must be reported in TCO Certified Portal once a year.
 - The total electricity consumption and the ratio of renewable electricity use for each final assembly factory must be reported in TCO Certified Portal once a year.
-

Draft 2

3.2.2 Clarification

Brand owner reporting period

The reporting by the brand owner must be submitted by 31 August each year. Each reporting period is the previous calendar year. The reporting applies until one year after the certificate has expired. Only electricity used and generated during the previous calendar year must be included in the report. Renewable electricity certificates may be procured up to three months after the reporting period as long as the applicable reporting period is specified on the REC (to avoid double counting).

Exception for new factories

For factories where no TCO Certified Generation 10 product was certified (for any brand) before 31 August. The brand owners manufacturing of certified products at this factory must be in compliance the following calendar year. However, the brand owner must still report the renewable electricity share of their manufacturing (even if not in compliance), each 31 August.

The ratio of renewable electricity may be reported at the factory or product level.

Brand owners can choose if to report on the whole factory level, or, on the manufacturing of their certified products. Reporting on their own manufacturing is useful if they want to purchase additional RECs for their own manufacturing to achieve a higher share than the factory.

In this case the electricity used to manufacture certified products is estimated based on the allocation of manufacturing volume, which is a common principle used in, for example, the Greenhouse Gas Protocol. This means that the total electricity consumption of the factory is allocated to individual products based on units manufactured.

For each reporting period and final assembly factory, the brand owner must report the following:

If the ratio of renewable electricity used by the factory is $\geq 15\%$ reporting may be done only on the factory level and must include:

- Documented proof of the total electricity consumption of the factory (X)
- Any RECs designated to the factory (with the factory name and region) for the renewable electricity (Y) generated or purchased by the factory during this period.

Calculations:

- The ratio of renewable electricity by the factory and in the assembly of certified products ($RF = (Y/X)$).

|

Draft 2

Otherwise, reporting must be more detailed and include:

- Documented proof of the total electricity consumption of the factory (X)
- Any RECs designated to the factory (with the factory name) for the renewable electricity generated or purchased by the factory during this period (Y).
- Documented proof of the total number of units of any kind manufactured (Z) and the number of certified units manufactured for the brand owner (W) during the period.
- Any RECs (S) designated to the factory and brand owner (with the factory name and brand name) specifically for the manufacturing of certified products.

Calculations:

- The estimated electricity used to manufacture certified products ($E = X/Z*W$)
- The ratio of renewable electricity by the factory ($RF = Y/X$).
- The ratio of renewable electricity by the brand owners manufacturing ($RC = S/E$)
- The ratio of renewable electricity in the assembly of certified products ($RT = RF+ RC$)

Exception for a high market price of RECs

If the market price of all allowed RECs in the market in question is above 10 USD / Mwh the applicant is allowed to source allowed I-REC accounting for 30% of the renewable electricity purchased from markets with neighboring borders.

If the market price of all allowed RECs in the market in question is above 30 USD / Mwh, the applicant is allowed to source allowed I-RECs accounting for 70% of the renewable electricity purchased from markets with neighboring borders.

Renewable electricity must be generated from:

- Wind,
- Solar,
- Geothermal,
- Hydropower (pumped hydro storage is not accepted)
- Biomass (agriculture waste and residues, forest biomass, biofuels plants)

Renewable energy certificates (RECs)

Renewable electricity can be purchased or generated. Factories can own their own projects. Projects might be on-site or off-site, on the grid, or entirely off-grid. The generation must be issued with renewable energy certificates (RECs). Factories can consume directly from their projects or retain the RECs, and claim the use of renewable electricity. They can also sell electricity to the grid, retain the RECs, and claim the use of renewable electricity.

Both for self-generation and market-purchased RECs the attributes (and certificates) must be sourced and purchased from within the same national region as the factory using the

[electricity. Also, the renewable electricity production facility for which the certificates are issued must be within the same national region. The national region constitutes a “market” for the purpose of transacting and claiming attributes. \(see exception to this above\).](#)

[A REC must be recognized on the list below to be accepted as proof of compliance. Credible systems may be added to the list after independent review and acceptance from TCO Development.](#)

Country	Accepted REC
Brazil	I-REC
Canada	REC, I-REC
China	I-REC, GEC
Czech Republic	EECS-GO
Egypt	I-REC
Hungary	EECS-GO
India	I-REC, Indian national EAC system
Japan	J-Credit, FIT-NFC, GEC
Malaysia	I-REC
Mexico	I-REC
Poland	National Guarantees of Origin
Portugal	EECS-GO
Singapore	I-REC
Taiwan	T-REC, I-REC, CPPA
Thailand	I-REC
USA	REC, I-REC
Vietnam	I-REC
South Korea	Korean national EAC system

Verification guidelines of factory data

- Documented proof of the total electricity consumption consists of all electricity contracts and bills (The total number is added to the Accepted Factory List and only needs to be verified once per factory and year).
- Proof of the total number of units manufactured and the number of certified units manufactured for the brand owner (W) during the period must be a copy of a document or digital system that can be verified during an onsite audit. (The total number is added to the Accepted Factory List and only needs to be verified once per factory, brand name and year).

Verification of Renewable Energy Certificates (RECs)

The brand owner must present proof that renewable energy certificates are exclusively owned by, have been permanently retained by or retired on behalf of the specific factory or by the brand manufacturing at the specific factory. This means that RECs designated to the factory must have the factory name on it, and RECs designated to the brands manufacturing at the factory must have both the factory name, and brand name on it (to avoid double counting).

Energy Attribute Certificates are part of tracking systems in which certificates are electronically serialized and issued to generators with accounts on the system. There they are traded and ultimately permanently retired when they are used to support a claim.

For more information on how to verify the authenticity of the REC with each certificate body such as the below listed, a guideline can be found here:

<https://tcocertified.com/industry/certification-documents/>

Simplified verification process of RECs:

1. The authenticity of the REC is verified with each certificate body.
2. The reporting period is within the 12+3-month window.
3. The amount of renewable electricity represented by the certificate.
4. The certificate ownership is to the specific factory (and brand owner) in question.
5. The certificate is retired (not for sale) when making a claim about renewable energy.

3.3 Energy management system

Background

A certified energy management system helps an organization work in a systematic way with energy performance; and make continuous ~~improvement~~[improvements](#) at both company and product levels. To be efficient, an energy management system must include independent, external reviews.

Definitions

~~Final assembly factory: Factory where the final assembly of the certified product takes place.~~
[See definitions chapter 2.0](#)

Applicability

All product categories

3.3.1 Mandate

- Each final assembly factory [and each factory](#) manufacturing [display panels >10" for the certified product](#) must [behave a structured energy management system independently](#) certified ~~in accordance with to~~ ISO 50001.

Submit the following to an approved verifier:

- A copy of a valid ISO 50001 certificate for [every each](#) final assembly factory [and each factory](#) manufacturing [panels >10" for the certified products-product](#).

~~Submit~~ The following ~~together with the application is submitted~~ to TCO

Development:

- A copy of a verification report from a verifier approved by TCO Development

3.3.2 Clarification

The applicant must ensure that a valid ISO 50001 certificate is available on TCO Certified Portal at all times; for every final assembly factory [and each factory](#) manufacturing [panels >10" for the certified products-](#)

[product](#). The certificate(s) or an appendix to the certificate(s) must [make it clear/clarify](#) what the certification covers.

Factories that do not yet have a certified energy management system according to ISO 50001, may apply to TCO Development for an extended ~~time~~ period of 24 months to complete certification by annually submitting an extension application on the ~~status of the~~ certification ~~status~~. This application and status template can be obtained from TCO Development.

TCO Development has the right to deny the applicant an extended period ~~of time~~ if there is a substantial risk that the factory will not be able to achieve ISO 50001 certification within the extended ~~time~~ period. The certificate must be issued by a certification body ~~that is~~ accredited by an accreditation body covered by the International Accreditation Forum, iaf.nu, Multilateral Arrangement on Energy Management Systems

3.4 Post-consumer recycled content

Background

Use of recycled materials lowers the environmental impact. The manufacturing of recycled plastics, if 100% recycled content is achieved, can reduce ~~the~~ energy consumption ~~by~~ up to 60 percent, compared to virgin plastics. Less raw materials are required to produce recycled plastics, which can lead to a reduced carbon footprint. Every metric ton of recycled plastic produced can result in up to 1-3 metric tons of carbon dioxide savings, compared to virgin plastics.

The long-term goal is that all materials in certified products are circulated and renewable where technically possible.

Definition

PCR – Post-consumer recycled: Post-consumer recycled materials are derived from used consumer products, often packaging, bottles, ~~and~~ durable goods including IT products. (I.e. aluminum cans, PET bottles). This does not include PCM material.

PCM - “Pre-consumer Material”: Material or by-products generated during the manufacturing of a product but before the product reaches the end-use consumer.

Applicability

All product categories.

3.4.1 Mandate

The following information for the ~~typical product~~~~worst-case~~ configuration (~~mandate 1.2.1–~~~~product specification~~~~lowest PCR content ratio~~) of the certified product (including any external power supply) must be reported:

- Percentage of post-consumer recycled plastics by weight versus the total weight of all plastics.
- Percentage of identified post-consumer recycled materials (plastic and non-plastic) by weight versus the product weight.

Submit the following to an approved verifier:

- [The completed post-consumer recycled content template](#)
- [Supporting documentation for all parts claiming PCR content.](#)
- A completed and signed product form (chapter 11.3).

- ~~Documentation on PCR content of all parts with a weight above 0.5g~~

Submit ~~The following together with the application~~ **is submitted** to TCO

Development:

- A copy of the verification report(s) from a verifier approved by TCO Development.
- Supporting documentation for all parts claiming PCR content.

The following is submitted to TCO Development and may be published:

- The total product weight (including external power supply) and configuration
- The weight of all plastics in the product.
- The weight of all post-consumer recycled plastics and other identified post-consumer recycled material in the product.

3.4.2 Clarification

~~Only post-consumer recycled content where the weight is confirmed by documented proof from the material vendor as described below may be reported.~~

The worst-case configuration (lowest PCR content by weight of total product weight) that is available for purchase must be defined and stated in the verification report. It must be defined through a unique brand owner code, a unique product identifier, or a list of configuration choices that are available at the time of purchase. *If there are several versions of the same component (e.g. due to different suppliers) and the buyer cannot influence which version they get, then the worst-case version of the component must be reported.*

All plastic parts with a weight above 0.5 grams must be accounted for in the Post-consumer recycled content & packaging template. Parts that are non-plastic and without PCR content do not need to be listed individually.

Document proof from ~~the material vendor must be provided for an independent third party covering~~ each part containing post-consumer recycled material must be provided if it is to be included in the PCR percentage.

~~If no proof exists then 0% must be reported.~~ TCO Development has the right to require a full bill of material.

Exceptions plastics

Optical components and display panels, electronic components, cables, connectors, PCBs, insulating mylar sheets, hard sheets for insulation, soft sheets for heat dissipation, elastomer feet, sponge materials, and labels may be excluded. This means that the weight of these

items is not included when calculating the total weight of the plastic in the product in this requirement. [The total product weight for the worst case configuration is calculated including these parts.](#)

The following information must be submitted to an approved verifier

For each plastic part with a weight above 0.5g, the following must be reported:

- Name of part/part ID
- Material manufacturer name
- [Identification marking of PCR material](#)
- Weight [of part](#) (grams)
- ~~Post-consumer recycled content in weight (grams)~~
- ~~For identified non-plastic~~ [Weight of plastics in part](#)
- [Weight of](#) post-consumer recycled content [\(grams\)](#)

[For other identified post-consumer recycled content:](#)

- Name of part/part ID
- Material manufacturer name
- ~~Weight (grams)~~
- Type of material
- [Weight of part \(grams\)](#)
- [Weight of](#) post-consumer recycled content ~~in weight~~ (grams)

[A PCR](#)

[The post-consumer recycled content](#) template is available at tcocertified.com/certification-documents and may be used to provide this information. Similar templates covering the same information ~~is~~[are](#) acceptable.

Clarification of sustainability performance indicator(s)

One or more “sustainability performance indicators” (chapter 1.3) are collected for this criterion. There is no mandatory level for these indicators but they must be verified and reported according to the description below.

Percentage of post-consumer recycled plastics (Class A-G)

Percentage of post consumer recycled plastics by weight versus the total weight of all plastic parts. All exceptions listed in the above clarification are applicable.

- **Class A:** $\geq 85\%$
- **Class B:** $\geq 70\%$
- **Class C:** $\geq 50\%$
- **Class D:** $\geq 30\%$
- **Class E:** $\geq 10\%$
- **Class F:** $> 0\%$
- **Class G:** 0%

Percentage of identified post-consumer recycled materials (Class A-G)

Percentage of identified post consumer recycled materials (plastic and non-plastic) by weight versus the typical product weight.

- **Class A:** $\geq 50\%$
- **Class B:** $\geq 40\%$
- **Class C:** $\geq 30\%$
- **Class D:** $\geq 20\%$
- **Class E:** $\geq 10\%$
- **Class F:** $> 0\%$
- **Class G:** 0%

3.5 Product carbon footprint

Background

Product Carbon Footprint (PCF) is one of the most established ways ~~for~~of determining the climate impact of a product. PCFs cover the whole life cycle of a product, from the raw material extraction to the recycling or disposal phase. Using product carbon footprints enables an overall picture in order to work on reductions and measures in the right places.

~~The accuracy of PCFs can vary enormously based on the methodology and type of source data used. As it is very time-consuming and costly to make accurate PCFs the majority of PCFs are based on very general source data. This results in large uncertainties making product comparisons useless.~~

Definitions

Primary data: ~~This term refers to data from specific processes within the supply chain of the user of the PCF method. Such data may take the form of activity data, or foreground elementary flows (life cycle inventory). Primary data are site-specific, company-specific (if multiple sites for the same product), or supply chain-specific. Primary data may be obtained through meter readings, purchase records, utility bills, engineering models, direct monitoring, material/product balances, stoichiometry, or other methods for obtaining data from specific processes in the value chain of the user of the PCF method.~~

Foreground-system processes: ~~This term refers to those processes in the product life cycle for which direct access to information is available. For example, the producer's site and other processes operated by the producer or its contractors (e.g. goods transport, head-office services, etc.) belong to the foreground processes~~

Applicability

All product categories.

3.5.1 Mandate

A ~~classification of the~~ PCF methodology must exist for each certified product, and its availability must be ~~conducted~~evaluated by an approved verifier.

Submit the following to an approved verifier:

- Necessary documentation for the PCF-evaluation of PCF availability
- A completed and signed product form (11.3).

Submit ~~The following~~ together with the application is submitted to TCO

Development:

- A copy of the verification report(s) from a verifier approved by TCO Development.
The classification

The following is submitted to TCO Development and may be published:

- ~~Type of the PCF method, and~~ availability must be reported in TCO Certified Portal.
- ~~Instructions on how to retrieve the PCF.~~

3.5.2 Clarification

~~It is not required to have conducted a PCF for the product. If no PCF data is available at the time of certification, the product will receive the lowest classification of the method, and availability. It is possible to submit data for PCF evaluation at any time in order to update the classification.~~

The PCF for the product is estimated based on product type data using either ISO 14040, ISO 14044, ISO 14067, ISO 14025, IEC TR 62921, PAS 2050, the WRI GHG Protocol Product Life Cycle Accounting and Reporting Standard, PAIA-tool, INEMI Eco-Impact Estimator or equivalent PCF standard.

For product models ~~which that~~ can be configured, the ~~typical product configuration must be used. The typical product configuration is defined as PCF for~~ the product ~~configuration which is expected to be manufactured in~~ must at least be based on the largest number product model family.

PCF Requirements

The product carbon footprint result must include the following:

1. Inputs used in the assessment (at a minimum, lifetime of the product, amount of electricity consumed in the use phase by the product per year, and significant product model elements/parameters).
2. Total life cycle carbon footprint and carbon footprint of the product's life cycle stages (at a minimum, manufacturing, use, transport, and end-of-life).
3. Explanation of uncertainty addressed either through a statistical assessment or through a disclaimer statement.

The PCF method (Class A-E)

Class A

- ~~The PCF for the product is based on the product model.~~
- ~~The PCF consists of primary data in foreground system processes.~~
- ~~The PCF is critically reviewed by a third party. The review report must at least include:~~
 - ~~Number of years experience in the LCA/PCF field~~
 - ~~Number of carbon footprints reviewed~~
 - ~~Number of carbon footprints conducted~~

Class B

- ~~The PCF for the product is based on the product model.~~

- The PCF is critically reviewed by a third party. The review report must at least include:
 - Number of years experience in the LCA/PCF field
 - Number of carbon footprints reviewed
 - Number of carbon footprints conducted

Class C

- The PCF for the product is based on the product model.

Class D

- The PCF for the product is based on the product model family.

- **Example**

- Similar chassis appearance

- Same display size

- Similar functionality (e.g. headset with microphone)

Class E

- No data available

Verification guideline

For Class C-E a general evaluation of the methodology together with a statement that this methodology will always be used can be made for each product category instead of providing proof for each certified product.

Availability ~~(Class A-D)~~

The availability of PCF increases the transparency of PCF methods used and enables future revisions.

Class A

Publicly available

- The results of the PCF as defined in the [PCRPCF](#) Requirements are publicly available and can be downloaded free of charge.
- A link to the download location is uploaded to TCO Certified Portal

Class B

Available on-demand

- The results of the PCF as defined in the [PCRPCF](#) Requirements are available on-demand from the brand owner.
- Instructions on how to retrieve the PCF is provided.

Class C

The results of the

Verification guideline

- ~~In order to determine if a PCF can be considered as defined in the PCR Requirements are not publicly available:~~

Class D

- ~~No PCF available~~

Verification guideline

For Class A, the verifier must:

1. Confirm that the PCF is available for download free of charge on the brand owners PCF repository
or
2. Confirm a public statement on the brand ownersowner's website, that at least all TCO Certified products will have the results of the PCF available online during product availability.

3.6 Product carbon footprint reductions

Background

Research conducted by IT sustainability research and consulting organization PX3, on 707 unique IT product models from 42 manufacturers shows that many manufacturers report no PCF value at all for several of their products. And for products that report PCF values, different manufacturers have chosen different methods to make the calculations. Add to this the complexity of the supply chain. This means that comparisons of PCF between products are more or less meaningless, and to draw correct conclusions from the comparisons and make sustainability-focused purchasing strategies based on these values meaningless also, and possibly even misleading.

One way to overcome this, until all manufacturers publish comparable and verified PCF values, is to look at average scope 3 calculations for different product types and instead focus on activities reducing product carbon footprint. In order to incentivize reductions of the carbon footprint, a list of accepted best practice solutions is included in TCO Certified and expanded over time. The implementation of any solution on this list is then verified by independent experts and may be published by TCO Development as an estimated reduction of the Px3 value representing the product's carbon footprint.

Applicability

All product categories.

3.6.1 Mandate

A comparable product carbon footprint value must be estimated for the certified product according to the Px3 methodology with any implemented reductions subtracted.

Submit the following to an approved verifier:

- Documented proof of the implementation of the claimed PCF reduction solution covering the manufacturing of the certified product.

The following is submitted to TCO Development:

- A copy of the verification report(s) from a verifier approved by TCO Development.
- All verified PCF reduction solutions, the period when the reduction is valid, and the total estimated reduction of the PCF must be reported in TCO Certified Portal.

The following is submitted to TCO Development and may be published:

- All verified PCF reduction solutions implemented and the total estimated reduction of the PCF.
-
-

3.6.2 Clarification

The Px3 values estimated for certified products make comparisons between products possible. This enables sustainability-focused purchasing strategies. For products where no reduction solution has been implemented, the default Px3 value (without any reduction) will be used for the certified product.

Claiming a reduction of the Px3 value

To claim a best practice solution on the list, a brand owner must provide documented proof of implementation of the solution covering the production of the certified product.

Adding new best practices to the list

Other solutions may be added as they get accepted by TCO Development. A description of the solution is then sent to an approved independent expert who will determine if the solution fulfills the requirements or not. To qualify for the list of best practices, the investigation must show that the proposed best practice solution:

- contributes to a measurable reduction of the total PCF that can be estimated as a reduction of the Px3 value.
- is possible to verify in a credible way
- is not already industry standard but instead pushes the majority of brand owners to improve their supply chains.
- is formulated so that it is not limited to a certain brand owner or proprietary technology.

All the supporting documentation and the conclusion from the expert are then sent to TCO Development, who will decide to update the list of best practices solutions.

Px3 value and list of best practice solutions to reduce the PCF

The Px3 value is the average product carbon footprint estimation that will be presented when no reduction solutions have been implemented. The list of best practice solutions that are accepted and will result in a reduction of the estimated PX3 value in the TCO Certified Product Finder can be found at: <https://tcocertified.com/industry/certification-documents/>

4 User health and safety

- A poorly designed IT product may cause discomfort and cause injury and health problems for the user.
- Fire hazard, electric shock and explosions are some of the risks associated with substandard products. They may also have a short lifespan which is negative from a sustainability perspective.
- A safe and ergonomically designed IT product supports productivity and can meet the user's needs longer.

Poor product design is a safety hazard

Product safety and functionality is fundamental to sustainability in the IT sector. Products that are uncomfortable or unsafe to use often have a short lifespan which leads to pollution, e-waste and high resource consumption. They may also cause health and safety problems for the user. Examples of identified safety hazards include product overheating and risk of fire, battery volatility which can lead to burning or explosion, and poor electrical safety design that may increase the risk of fire or electric shock.

Our approach: verifying product safety, protecting the user

An IT product must be safe to use and should provide the user with the necessary function and comfort for a long time. To be efficient, criteria for user health and safety aspects must be specific, and tailored to each product category.

Criteria in chapter 4 focus on:

- Requiring that products are safe to use and that the user's risk of injury is minimized.
- Making sure that any cases of burning, explosion and electric shock are prevented.
- Limiting specific risks through criteria adapted for each product category.

4.1 Electrical safety

Background

IT products must be safe to use. Electrical safety refers to the electrical design of the product. Electrical insulation and other arrangements must be in place to prevent the user from touching live components. Faulty or inadequate electrical insulation can also result in an electrical flashover that may cause a fire or an explosion.

Applicability

All products with built-in ~~power supplies as well as any or~~ external power ~~supply intended to be used together with the product~~supplies.

References

4.1.

4.1.1 Mandate

The product and external power supply/supplies must be certified according to ~~EN/IEC~~ 62368-1 edition 2 or newer.

Submit the following to an approved verifier:

- A copy of a valid CB certificate ~~or a national certificate from a CB member (NCB)~~ for the product.

~~Submit~~ The following ~~together with the application~~is submitted to TCO

Development:

- A copy of the verification report(s) from a verifier approved by TCO Development.

4.1.2 Clarification

[For products classified as medical equipment, IEC 60601-1 version 3.2 or newer can be used instead of IEC 62368-1.](#)

4.2 Alternating electric fields

Background

Electrical alternating fields are created between objects that have different levels of electrical potential that change over time. When the potential changes in a periodic manner, an electrical alternating field is set up, with a field strength and a frequency. An IT product can contain many sources of electrical alternating fields. The field characteristics depend on the actual electrical potential difference and the distance from the product.

Some users are concerned that electric alternating fields may be a health risk. The aim of this criteria is to reduce the electrical alternating fields to such a low level so as not to burden the work and home environment with unnecessary factors. The mandatory criteria should not be regarded as hygienic limit values.

Applicability

All displays and all-in-one PCs that are delivered with a stand.

4.2.1 Mandate

Band I: 5 Hz to 2 kHz, ≤ 10 V/m

- Displays ≤ 26 " are measured at 0.30 m and 0.50 m in front of the product.
- Displays > 26 " are measured at 0.50 m in front of the product.

Band II: 2 kHz to 400 kHz, ≤ 1.0 V/m

- Displays ≤ 26 " are measured at 0.30 m in front of- and 0.50 m around the product.
- Displays > 26 " are measured at 0.50 m from the surface around the product.

Submit The following ~~together with the application~~ is submitted to TCO

Development:

- A copy of the test report(s), and a copy of the verification report(s) from a verifier approved by TCO Development.

4.2.2 Clarification

Test facility requirements

Background electric field strengths in the test facility, including disturbances transmitted by power lines and internally generated noise in the measuring system, must together not exceed

2.0 V/m in band I and 0.20 V/m in band II. The mains voltage to the product must be within 3 % of its nominal value.

Preparation of the product for testing

All necessary preparations described in 9.1 and 9.3 must be done. An external optical filter may not be used in order to comply with the mandatory requirement.

Equipment

Alternating electric field meter.

Test method

Compliance may be verified in three ways.

1. Technical judgement

Several thousands of products have been tested for this mandate since 1992. It is now clear that for LCD displays the measured values are predictable and only in very rare cases exceed the mandated levels as long as the product is correctly grounded.

This testing is time consuming and currently offer limited value as it is almost certain that the product will pass as long as it's grounded. Therefore, the approved verifier may verify compliance based on technical judgement that the product is correctly grounded. The technical judgement template is signed by both the approved verifier and the applicant. If the product has an external power supply then the approved verifier must also verify that the ground is going through from the power plug to the secondary side of the powers supply.

2. Quick check

If the approved verifier finds that the technical judgement is not enough, a quick check may be made to verify if complete testing is necessary or not. The test object is placed on the turntable as described in the instructions for complete testing below. The measurement point should be 30 cm from the center center point in front of the product. An uncertainty of 5 cm is accepted in each direction x, y and z for this quick check which makes it acceptable to use visual positioning with a ruler. If the measured result is below 4.0 V/m in Band I and 0.4 V/m in Band II, the product can be considered to comply with the requirements in this mandate without further testing.

3. Complete testing

If the results from the quick check exceed the limits defined in the mandate, or if the approved verifier believes that the product may be non-compliant due to the product design or other reasons, then complete testing of the product must be carried out.

The true r.m.s.-value of the amplitude of the electric field strength, at the surface of the measuring probe, is measured in front of the product in band I and in four azimuths in band II. The frequency ranges are selected by means of filters in the measuring equipment.

Screens smaller or equal to 26"

The product must be positioned so that the tangential plane, to the centre-centre point of the screen surface, is at a right angle of the horizontal plane. The distance between the centre-centre points of the screen surface and the back of the product, including any part of a stand holder, along the normal to this tangential plane is called L, see figure *alternating electric fields 1*.

The origin of the cylindrical coordinate system must be situated at a distance $L/2$ behind the screen surface on the normal to the tangential plane through the centre-centre point. The z-axis must be at a right angle to the horizontal plane. The angular reference direction is along the above mentioned normal in the direction pointing outwards from the screen. An angle (ϑ) is positive in the counterclockwise direction. The measurement instrument is moving in a counter-clockwise direction around the test sample (as illustrated in the figure *alternating electric fields 1*).

Measurements must be made at all points that have a minimum clearance of 0.25 m to the outer surface of the product and with coordinates according to:

$$z = 0$$

$$r = (L/2 + 0.5) \text{ m (at the front also } (L/2 + 0.3) \text{ m)}$$

$$\vartheta = 0 \text{ for band I}$$

$$\vartheta = 0, 90, 180 \text{ and } 270 \text{ for band II}$$

If clearance is less than 0.25 m, the instrument must be moved out radial until 0.25 m clearance is achieved.

Distances are given in metres and angles in degrees. The coordinates are given for the centre of the measuring probe. The surface of the probe must be perpendicular, within ± 5 , to the radial axis.

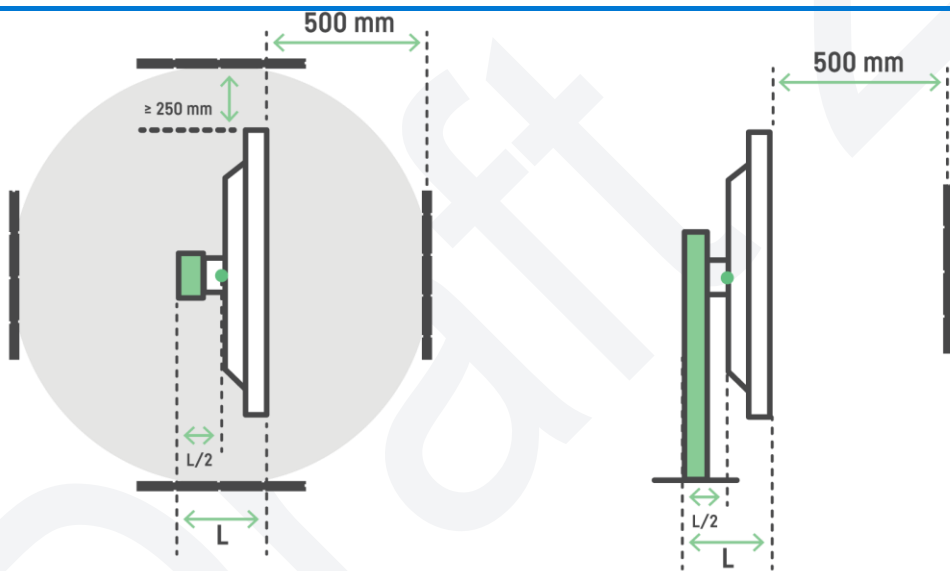
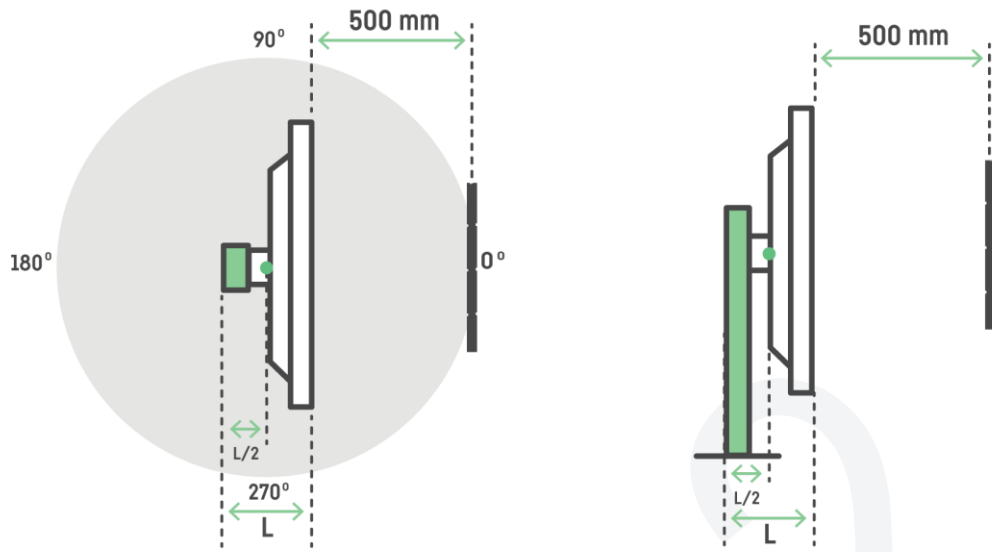

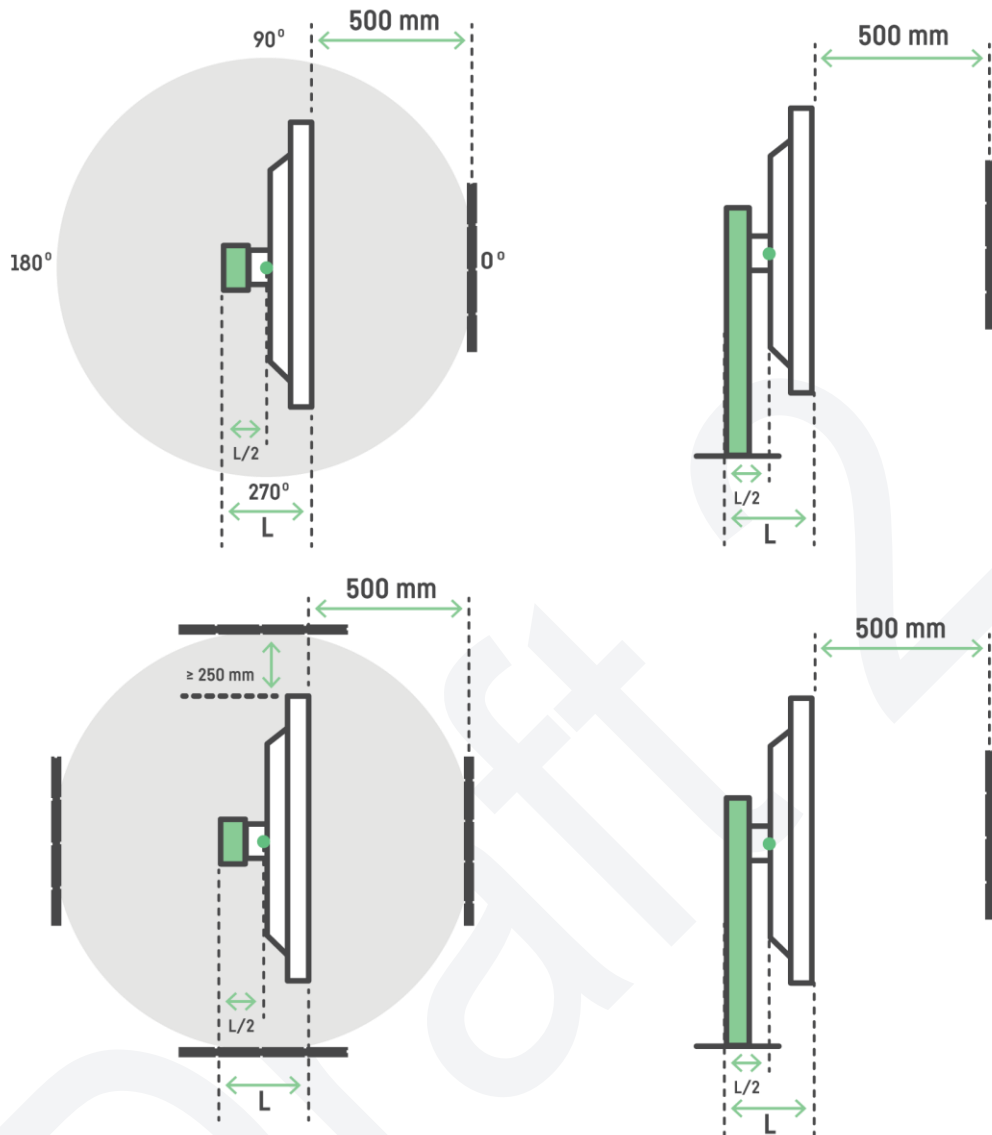

Figure *alternating electric fields* 1. Measurement geometry for band I (top) and band II (bottom).

Screens larger than 26"

For screens larger than 26", measurements must be taken in four directions around the product at 0°, 90°, 180°, 270°. All measurements must be taken at 0.5 m from the surface of the product.

For products that have a width or height ≥ 1 m, additional measuring positions for front, rear and sides are required.

The width and height of the screen does not include the frame but only the viewable screen area. The number of positions depends on the size of the screen and is given in horizontal and

vertical direction by the width and height in metres of the screen divided by 0.5 rounded to the closest integer. The positions must be equally divided over the screen surface. See figure *alternating electric fields 2*.

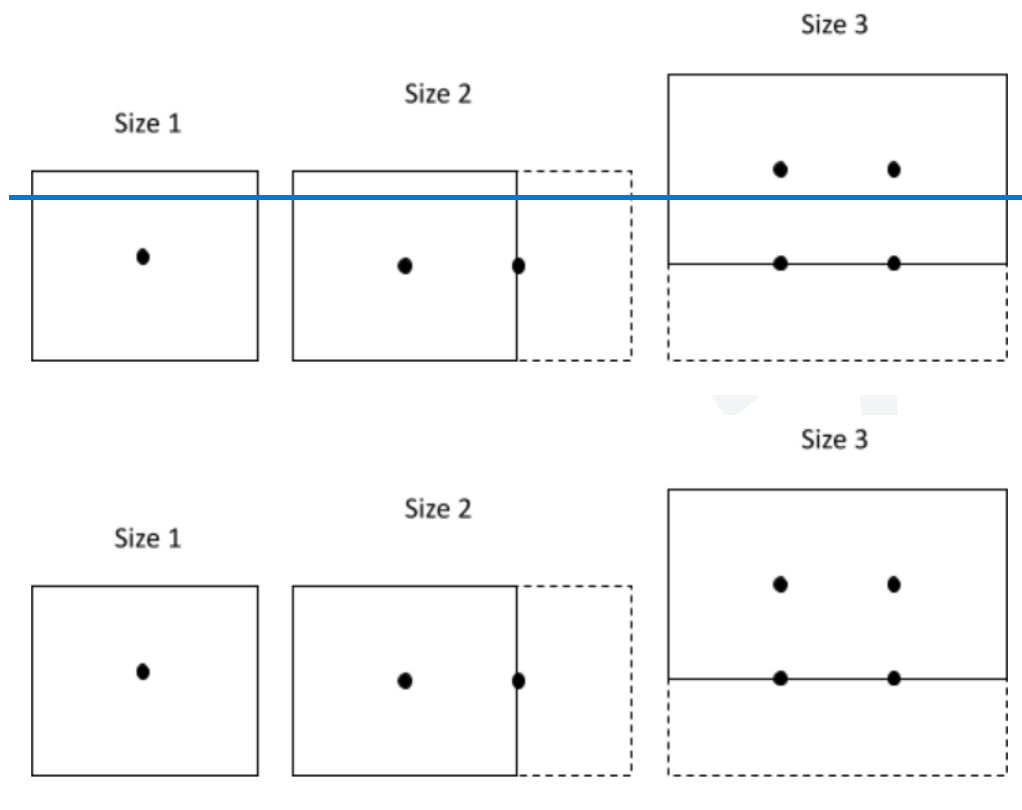

Figure *alternating electric fields 2*. Measurement point on different screen sizes. The dotted lines indicate a screen increase from size 1 by 0.5 m in width and then 0.5 m in height.

The product and the measuring probe must be positioned at least 1 m from all significant metallic structures and objects apart from the test object.

Additional units and connecting cables necessary for the operation of the product, that are not part of the test, must be placed so far away from the measuring setup that the fields they emit do not influence the measurement. Shielding may be added to these units and cables, as long as the 1 m clearance is maintained.

The measuring probe must be connected to ground. Any cables running between the measuring probe and the measuring instrument must be positioned in such a way that they do not influence the measured value.

The power cable of the test object must be connected to the phase and the neutral conductors of the mains power supply. If the mains power supply plug permits an interchange

of the live and neutral conductors, measurements must be taken with the connection that gives the highest reading in band I.

Test evaluation

Results must be presented as r.m.s. values of the alternating electric field expressed in volt per meter (V/m). For band I, results must be presented as the measured values at 0.3 m and 0.5 m for normal and stand-by operations if they differ. For band II, the measured values in front of the product and the maximum value at rotation must be presented for normal and stand-by operations if they differ.

If the measured values are less than 10.0 V/m in band I or less than 1.0 V/m in band II the result must be reported as "< 10.0 V/m" or "<1.0 V/m", respectively.

If measuring more than one position on the front, rear or sides of the screen the worst-case must be given in the report.

Overall uncertainty

The test must be performed in such a way that the total extended uncertainty in the test result will be less than $\pm (10 \% \text{ of the reading} + 1.5 \text{ V/m})$ for band I and $\pm (10 \% \text{ of the reading} + 0.1 \text{ V/m})$ for band II.

4.3 Alternating magnetic fields

Background

Alternating magnetic fields are created when an alternating electrical current flows through a conductor. IT products are surrounded by alternating magnetic fields that are generated by different parts of the product, e.g. power supply unit, voltage inverters and other electrical circuits. The field strength depends on the actual electric current and on the distance from the product.

Some users are concerned that alternating magnetic fields may be a health risk. The aim of this criteria is to reduce the magnetic alternating fields to such a low level as not to burden the work and home environment with unnecessary factors. The mandatory criteria must not be regarded as hygienic limit values.

Applicability

Displays and all-in-one PCs that are delivered with a stand.

4.3.1 Mandate

Band I: 5 Hz to 2 kHz, ≤ 200 nT

- Displays ≤ 26 " are measured at 0.30 m in front of, and at 0.50 m around the product.
- Displays > 26 " are measured at 0.50 m from the surface of the product around the product.

Band II: 2 kHz to 400 kHz, ≤ 25 nT

- Displays ≤ 26 " are measured at 0.50 m around the product.
- Displays > 26 " are measured at 0.50 m from the surface of the product around the product.

Submit The following ~~together with the application~~ is submitted to TCO

Development:

- A copy of the test report(s), and a copy of the verification report(s) from a verifier approved by TCO Development.

4.3.2 Clarification

Test facility requirements

Background magnetic fields in the test facility, including disturbances transmitted along the power line and internally generated noise in the measuring system, must together not exceed 40 nT in band I and 5 nT in band II.

Preparation of the product for testing

All necessary preparations described in 9.1 and 9.3 must be done.

Equipment

Alternating magnetic field meter in band I and band II.

Test method

Compliance may be verified in three ways.

1. Technical judgement

Several thousands of products have been tested for this mandate since 1992. It is now clear that for LCD displays the measured values are predictable and very rarely exceed background levels in the test chamber.

This testing is time consuming and currently offers limited value as it is almost certain the product will pass. Therefore, the approved verifier may verify compliance based on technical judgement that the product has a well known design that the lab has already tested several times. The technical judgement template is signed by both the approved verifier and the applicant.

2. Quick check

If the approved verifier finds that the technical judgement is not enough, a quick check may be made to verify if complete testing is necessary or not.

The test object is placed on the turntable as described in the instructions for complete testing below. The measurement point should be 30 cm from the center center point in front of the product. An uncertainty of 5 cm is accepted in each direction x, y and z for this quick check which makes it acceptable to use visual positioning with a ruler. One measurement is taken in this position. If the measured result are below 80 nT in Band I and 10 nT in Band II, the product can be considered to comply with the requirements in this mandate without further testing.

3. Complete testing

If the results from the quick check exceed the limits defined in the mandate, or if the approved verifier believes that the product may be non-compliant due to the product design or other reasons, then complete testing of the product must be carried out.

Screens smaller or equal to 26"

The true r.m.s. value of the amplitude of the magnetic flux density vector is measured at twelve points on a cylindrical surface around the test object in the two frequency ranges, band I and band II. The frequency ranges are selected by specified filters in the alternating magnetic field meter.

The measuring geometry is illustrated in figure *alternating magnetic fields 1*. The measurement points are mathematically defined in the following way.

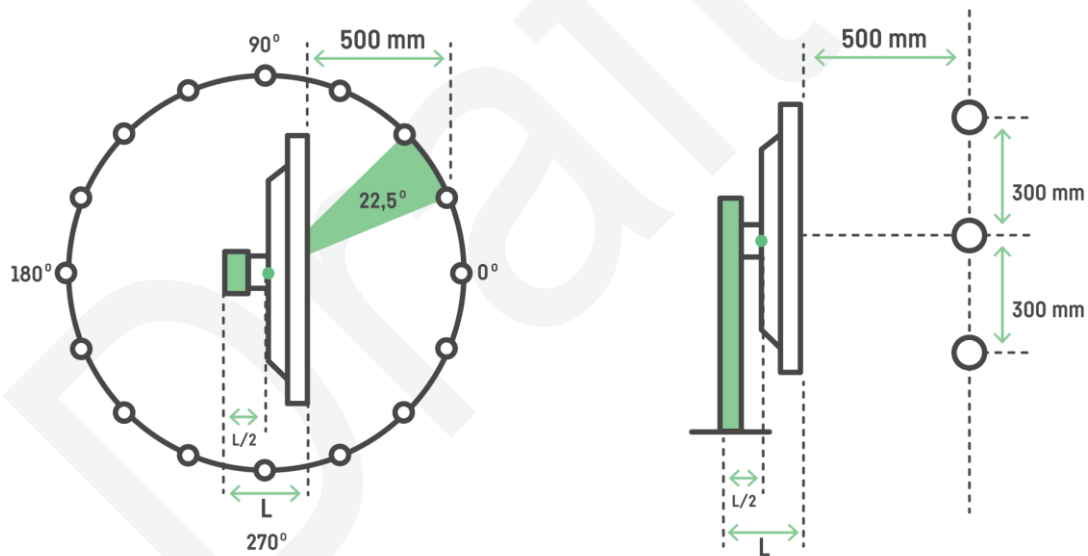
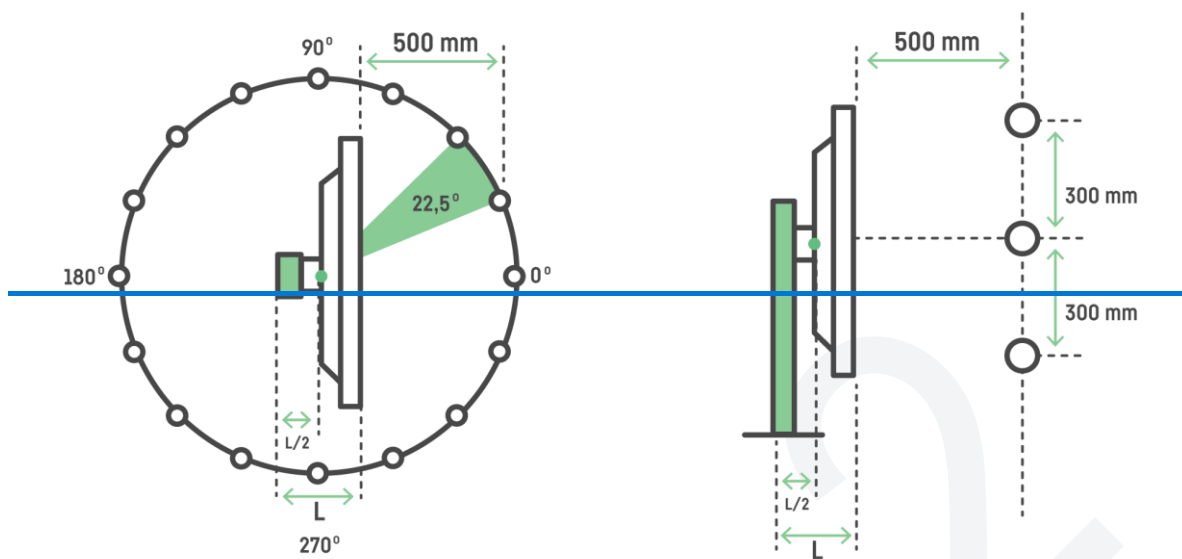

Figure alternating magnetic fields 1. Measurement geometry for the test object.

The product must be positioned so that the tangential plane, to the centre-centre point of the screen surface, is at a right angle of the horizontal plane. The distance between the centre-centre points of the screen surface and the back of the product, including any part of a stand holder, along the normal to this tangential plane is called L.

The origin of the cylindrical coordinate system must be situated at a distance $L/2$ behind the screen surface on the normal to the tangential plane through the centre-centre point. The z-axis must be at a right angle to the horizontal plane. The angular reference direction is along the above-mentioned normal in the direction pointing outwards from the screen. An angle (ϑ) is positive in the counterclockwise direction. The measurement instrument is moving in a counter-clockwise direction around the test sample (as illustrated in the figure *alternating magnetic fields 1*). Measurements must be made at all points that have a minimum clearance of 0.25 m to the outer surface of the product and with coordinates according to:

$z = -0.3 \text{ m}, z = 0 \text{ and } z = +0.3 \text{ m}$

$r = (L / 2 + 0.5) \text{ m}$ (at the front also $(L / 2 + 0.3) \text{ m}$ in band I)

$\vartheta = p \cdot 22.5^\circ$ where p represents all integers in the range $1 \leq p \leq 15$.

In case of less than 0.25 m clearance the instrument must be moved out radial until 0.25 m clearance is achieved.

Screens larger than 26"

For screens larger than 26" measurements must be taken in four directions around the product at $0^\circ, 90^\circ, 180^\circ, 270^\circ$. All measurements must be taken at 0.5 m from the surface of the product.

For products that have a width or height $\geq 1 \text{ m}$ additional measuring positions for front, back and sides are required.

- The width and height of the screen does not include the frame but only the viewable screen area.
- The number of positions depend on the size of the screen and is given in horizontal and vertical direction by the width and height in cm of the screen divided by 0.5 rounded to the closest integer.
- The positions must be equally divided over the screen surface. See figure *alternating electric fields 2*.
- Distances are given in metres and angles in degrees.
- The measuring coils must be stationary during the measurements.
- For display luminance settings – see chapter 9, General test conditions for emissions.
- The power cable of the test object must be connected to the phase and the neutral conductors of the mains power supply.
- The product does not need to be measured with the phase and neutral interchanged, as the magnetic fields are not influenced by such a change.

Test evaluation

Results must be presented as r.m.s. values of the magnetic flux density expressed in nanotesla (nT) for the two frequency bands. The values in front of the product and the maximum value and its position must be given both for normal and for standby operation if they differ. If measured values are less than 200 nT in band I or less than 10.0 nT in band II the result must be reported as "< 200 nT" or "< 10.0 nT" respectively.

Overall uncertainty

The test must be performed in such a way that the total extended uncertainty in the test result will be less than (10 % of the reading + 30 nT) for band I and (10 % of the reading + 1.5 nT) for band II.

Note

The uncertainties given are worst case limits. In many cases it will be possible to obtain better accuracy, especially in band II.

4.4 Acoustic noise

Background

Acoustic noise from fans, disk drives, etc. can be disturbing to users. Therefore, IT products should be as silent as possible during use. To make it possible for the user to choose a product with a comfortable noise level and frequency characteristics, this information should be reported.

To provide comparable information about acoustic noise levels, the A-weighted sound power level (L_{WA}) in operating and idling mode must be measured in accordance with ISO 7779:~~2010~~[2018](#) and reported in accordance with ISO 9296 p.4.4.1 in bels (B). As these standards do not include any clear definition of operating and idling mode, the following definitions apply for these modes and for the reported sound values:

Definitions

Sound power level (L_w): Total emitted sound power from a sound source, given in bels (B) and with the reference 1 pW

A-weighting: The measured linear sound level (sound pressure or sound power) weighted against the sensitivity of the human ear for different frequencies (A-curve).

Reported A-weighted sound power level (L_{WA}): in bels (B). Defined in accordance with ISO 9296 3.2.5.

Operating mode: A condition in which the system ~~and hard disk drive~~ must be operated, at a load equal to or higher than “~~operating mode~~[Web browsing](#)” & “[Office productivity](#)” for personal computers and workstations defined in ECMA-74 [20th edition](#) (C.15.3).

Idling mode: A condition in which the system must be operated, at a load equal to or higher than “idling mode” for personal computers and workstations defined in ~~defined in~~ ECMA-74 (C.15.3).

Applicability

All-in-one PCs with integrated moving parts.

References

4.2, 4.3, 4.4, 4.5, 4.6, 4.7, 4.8

4.4.1 Mandate

1. The reported A-weighted sound power level (LWAd) must not exceed:

Operating mode: 4.4B

Idling mode: 3.9B

If the product does not emit prominent discrete tones according to procedures specified in ECMA 74 Annex D, a higher reported A-weighted sound power level (LWAd) is accepted but must not exceed:

Operating mode: 4.7B

Idling mode: 4.2B

2. The A-weighted sound power level for a product must be reported in the product data sheet and/or in any other product descriptions.

Submit the following to an approved verifier:

- A copy of the test report(s) from a laboratory accredited according to ISO 17025.
- A completed and signed product form (chapter 11.3).

Submit The following ~~together with the application~~ submitted to TCO

Development:

- A copy of the test report(s), and a copy of the verification report(s) from a verifier approved by TCO Development.

The following is submitted to TCO Development and may be published:

- The A-weighted sound power level must be reported in TCO Certified Portal.

4.4.2 Clarification

The acoustic noise test must only be carried out if the product has any internal moving mechanical parts. This noise measurement is to be carried out at any test facility accredited according to ISO 17025, but the test report must be verified by a verification organization approved by TCO Development. The verifier must sign a verification document for noise, covering all configurations.

Prior to testing, the computer must have been switched on for 15 minutes. Switch on the computer and begin recording elapsed time starting immediately after completing any log in activity necessary to fully boot the system. Once logged in with the operating system fully loaded and ready, close any open windows so that the standard operational desktop screen or equivalent ready screen is displayed. Exactly 15 minutes after this, run the sample in accordance with ECMA-74 [20th edition \(or a more recent version\)](#) and start to accumulate test noise levels.

[The required operating modes for testing are “Web browsing” & “Office productivity”. The worst case value of these two modes should be reported.](#)

[The PC mark “Web Browsing” test under “Essentials” may be used for the “Web browsing” operation mode.](#)

[For PC Mark, the productivity testes are “Writing” and “Spreadsheets”, in SYSMark it is called “Productivity”](#)

The noise measurements must follow ISO 7779:[2010](#)[2018](#) and must be reported according to ISO 9296:1988. (However, the principle for how the measurement uncertainty is handled must be the same as for all the other criteria in the certification. This means that no uncertainty must be added to the result presented in the report.)

In addition to reporting the measured A-weighted sound power level (L_{WA}) in Bels (B), the single measurement values of the 9 measurement positions and the mean value of these A-weighted sound pressure level (L_{pA}) in decibels (dB) must be included in the test report.

Overall uncertainty

The test must be performed in such a way that the total extended uncertainty in the test result will be less than $\pm 2.5\text{dB}$.

Note

The uncertainties given are worst case limits. In many cases it will be possible to obtain better accuracy.

Workload ergonomics

Workload ergonomics refers to the adaptation of the tasks, tools, workspace and physical environment where the product will be used. These criteria are put in place in order to meet the user's needs for a good work environment.

Electronic devices are, just like furniture, lighting and other equipment, an important part of the modern workspace. TCO Development wants to contribute to the development of products that feature user characteristics based on the principles of good workload ergonomics. Ergonomic design enhances the possibility for users to be able to have high quality products that allow for physical variation.

It is important that products offer users the ability to vary their work posture. An aesthetically appealing design should not restrict ergonomic function.

Displays larger than 26" are not normally used in a typical workspace. They are also not considered to be easily movable on a normal display stand but are often placed on wall mounts. They are therefore excluded from the Workload ergonomics criteria. Some displays are sold without any kind of stand device. This can be in order to mount the display on walls or on a custom VESA compatible stand by the end user. Such displays are also excluded from Workload ergonomics criteria.

4.5 Vertical tilt

Background

It is beneficial to be able to tilt the display in the vertical plane. This creates the possibility to tilt the display back and achieve a 90 degree viewing angle. This offers the user the option of altering work posture for maximum comfort and also to obtain the best visual ergonomics of the product.

Applicability

Displays and all-in-one PCs $\leq 26"$ that are delivered with a stand.

References

4.9-4.18.

4.5.1 Mandate

Displays $\leq 26"$ must allow a backward tilt of at least 20 degrees in the vertical plane.

Submit the following to an approved verifier:

- A completed and signed product form (chapter 11.3).

Submit The following ~~together with the application~~ **is submitted** to TCO

Development:

- A copy of the verification report(s) from a verifier approved by TCO Development.

4.5.2 Clarification

It must be possible to tilt the display at least 20° backwards from an upright position (vertical plane) in at least one of the height positions.

The measurement of 20 degrees backwards tilt starts from the vertical plane (0 degrees). Some displays may have a starting position (minimal tilt) that is already tilted backwards, for example 5 degrees. If this is the case then it must be possible to tilt the display another 15 degrees to achieve the full 20 degree requirement. However, the starting position (minimal tilt) must not be more than 10 degrees backwards.

1° test tolerance is allowed. This is a tolerance for test set up and not for the test sample.

Draft 2

4.6 Vertical height

Background

For long-term display use, a straight or slightly downward viewing angle is important for maintaining good posture and visual comfort. The top of the active display area must not be positioned above the normal line of sight (0° - 15° below horizontal), so that users do not need to tilt the neck backwards to look at the display. This is even more important for users with bifocal or multifocal glasses who will be forced to tilt the head backwards if the display is positioned too high. A height adjustment function is recommended to allow the user to change position and achieve optimal visual ergonomics conditions.

Applicability

Displays and all-in-one PCs $\leq 26''$ that are delivered with a stand.

References

4.9-4.20.

4.6.1 Mandate

Displays $\leq 26''$ must meet at least one of the following mandates:

1. With the display aligned vertically in its lowest point of height adjustment, the distance measured from the underside of the display's foot (desktop surface) to the upper edge of the active screen area must be ≤ 42 cm.
2. The product must have a mounting interface applicable to the VESA mounting interface standard.

Submit the following to an approved verifier:

- A completed and signed product form (chapter 11.3).

Submit The following ~~together with the application~~ **is submitted** to TCO

Development:

- A copy of the verification report(s) from a verifier approved by TCO Development.

4.6.2 Clarification

The height requirement level in mandate 1 is based on documented anthropometric data for the eye height variance for adults in the 2.5-97.5 percentile. The shortest distance between eye and work surface level is taken from the 2.5 percentile of adults. The distance is from the operator's elbow (work surface height) to eye level. With a maximum height measurement set for displays that cannot be height adjusted, these operators will avoid the need to extend the neck backwards when scanning the screen.

The height of the population in the US and Europe has been documented in the "humanscale"

- The 2.5 percentile of the population in these regions is 145 cm. According to the "humanscale" this gives an eye height of 42 cm from the table top surface.
- The height measurement must be taken with the display in normal (non-tilted) position standing directly on a flat surface and at the lowest point of height adjustment. The measurement must be taken from the table surface to the upper edge of the active screen area – see figure *vertical height 1*.

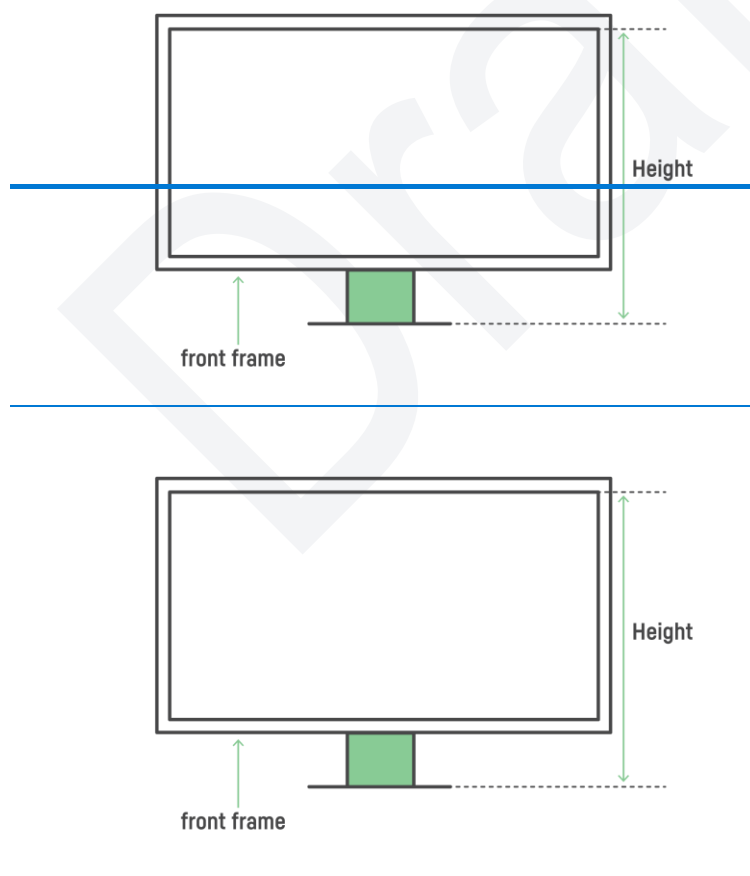

Figure vertical height 1.

Draft 2

5 Product performance

- A low-performing product can reduce user productivity and satisfaction. It may therefore be discarded prematurely.
- High energy consumption can lead to large emissions of greenhouse gases, which contributes to the climate crisis.
- By taking both product performance and environmental factors into account, user productivity can improve and the device can be in use for a longer time.

Low product performance reduces productivity and is a sustainability risk

Product performance is essential for user satisfaction and productivity. Low-performing products are also problematic from a sustainability perspective — in many cases, these products have a shorter lifespan, which leads to pollution, e-waste and high resource consumption. Discarding products prematurely is often also more costly for the purchasing organization.

Our approach: balancing product performance with energy efficiency

Product performance, user satisfaction and the development of more circular IT products are interconnected. In order for IT products to be more sustainable, all these factors need to be prioritized. Balancing product performance with energy efficiency is also important to reduce the product's climate impact.

High-performance products can meet the user's needs for a longer period of time. This way, the product's service life can be extended, which is an extremely important factor in reducing resource consumption, reducing greenhouse gas emissions and the amount of e-waste produced. Using the product for a longer time is also often better from an economic perspective, and provides a lower total cost of ownership for the purchasing organization.

Criteria in chapter 5 focus on:

- Requiring that product performance is balanced with energy efficiency through specific criteria for each product category.

5.1 Energy efficiency

Background

The IT industry and people's IT usage are large sources of greenhouse gas emissions, which remain the leading factor in climate change. As the number of IT equipment in use grows, greenhouse gas emissions are also increasing. Reducing the problem requires a number of measures, of which energy-efficient products are one part.

This criterion focuses on energy efficiency in the use phase and helps purchasing organizations independently verify that the IT product they source meets the energy efficiency requirements of ENERGY STAR.

Applicability

All-in-one PCs and desktops.

References

5.1.

5.1.1 Mandate

Calculated Typical Energy Consumption (E_{TEC}) for Desktop, Integrated Desktop (All in one PCs) The energy consumption and Thin Client shall be less than or equal to the maximum TEC (E_{TEC_MAX}) as calculated below:
(E_{TEC_MAX}) per Equation below:

$$E_{TEC_MAX} = (1 + ALLOWANCE_{PSU}) \times (TEC_{BASE} + TEC_{MEMORY} + TEC_{GRAPHICS} + TEC_{STORAGE} + TEC_{INT_DISPLAY} + TEC_{SWITCHABLE} + TEC_{EEE})$$

Where:

$ALLOWANCE_{PSU}$ is an allowance provided to power supplies that meet the optional more stringent efficiency levels specified in Table 1; power supplies that do not meet the supply requirements receive an allowance in version 8 of 0; the ENERGY STAR® program for computers must be fulfilled.

- TEC_{BASE} is the base allowance specified in Table 2; and,
- $TEC_{GRAPHICS}$ is the discrete graphics allowance as specified in Table 2, with the exception of systems with integrated graphics, which do not receive an allowance, or

~~Desktops and Integrated Desktops with switchable graphics enabled by default, which receive an allowance through $TEC_{SWITCHABLE}$ and TEC_{MEMORY} , $TEC_{STORAGE}$, $TEC_{INT_DISPLAY}$, $TEC_{SWITCHABLE}$, TEC_{EEE} and $TEC_{MOBILEWORKSTATIONS}$ are added allowances as specified in Table 3.~~

Submit the following to an approved verifier:

- A copy of the test report(s) from a laboratory accredited according to ISO 17025.

Submit The following ~~together with the application~~ is submitted to TCO

Development:

- A copy of the test report(s), and a copy of the verification report(s) from a verifier approved by TCO Development.

The following is submitted to TCO Development and may be published:

- The measured energy values and product configuration must be reported in TCO Certified Portal

5.1.2 Clarification

~~TCO Certified energy efficiency requirements~~

~~The energy efficiency requirements are harmonized with EnergyStar version 7.1 for computers. Products which have a valid EnergyStar version 7.1 (or a more recent version) test report may use this as proof of compliance.~~

~~For products which are configurable in such a way that only some configurations meet a more recent version of ENERGY STAR such as Energy Star for computers version 8, The product must be tested according to version 8 (or a more recent version) of the mandate.~~

~~Measured energy consumption according to ENERGY STAR®, as well as Typical Energy Consumption (TEC) and the allowed maximum consumption (TEC_{MAX}) program for each category (I1 I2, d1 d2 or 0 2) must be submitted to TCO Certified Portal, together with the application.~~

~~computers. Testing may can be carried out at any test facility accredited according to ISO 17025, but the test report must be verified by a verification organization approved by TCO Development. The minimum version of EnergyStar that all product configurations are able to meet will be presented on the certificate.~~

~~Table 1: Power Supply Efficiency Allowance~~

Draft 2

Table 2: Base TEC (TEC_{BASE}) Allowances for Desktop or Integrated Desktops (All in one PCs)

Table 3: Functional Adder Allowances for Desktop, Integrated Desktop(AIOs)Thin Client

Equation 1: Calculation of Allowance for Enhanced Performance Integrated Displays

$$EP = \begin{cases} 0, & \text{No Enhanced Power Displays} \\ 0.3, & \text{Enhanced Performance Display } d < 27 \\ 0.75, & \text{Enhanced Performance Display } d \geq 27 \end{cases}$$

Where

- ii ——— EPs shall meet the specified requirements when tested using the Uniform Test Method for Measuring the Energy Consumption of External Power Supplies, Appendix Z to 10 CFR Part 430. IPSs shall meet the specified requirements when tested using the EPRI 306 Generalized Internal Power Supply Efficiency Test Protocol, Rev. 6.6
- iv ——— Discrete Graphics capability is categorized based on frame buffer bandwidth, as shown in Table 9:
- v ——— $P = [\# \text{ of CPU cores}] \times [\text{CPU clock speed (GHz)}]$, where # of cores represents the number of physical CPU cores and CPU clock speed represents the Max TDP core frequency, not the turbo boost frequency.
- vi ——— TEC_{MEMORY} Adder: Applies per GB installed in the system.
- vii ——— $TEC_{GRAPHICS}$ Adder: Applies to only the first dGfx installed in the system, but not Switchable Graphics.
- viii ——— FB_BW : Is the display frame buffer bandwidth in gigabytes per second (GB/s). This is a manufacturer declared parameter and should be calculated as follows: $(\text{Data Rate [Mhz]} \times \text{Frame Buffer Data Width [bits]}) / (8 \times 1000)$.
- ix ——— $TEC_{SWITCHABLE}$ Incentive: Applies to automated switching that is enabled by default in Desktops and Integrated Desktops.
- x ——— TEC_{EEE} : Applies per IEEE 802.3az compliant (Energy Efficient Ethernet) Gigabit Ethernet port.
- xi ——— $TEC_{STORAGE}$ Adder: Applies once if system has more than one Additional Internal Storage element.
- xii ——— $TEC_{INT_DISPLAY}$ Adder: EP is the Enhanced Performance Display allowance calculated per Table 28; r is the Screen resolution in megapixels; and A is viewable screen area in square inches.

Calculation of E_{TEC_MAX} for Thin Clients

$$E_{TEC_MAX} = TEC_{BASE} + TEC_{GRAPHICS} + TEC_{WOL} + TEC_{INT_DISPLAY} + TEC_{EEE}$$

Where:

- TEC_{BASE} is the Base Allowance specified in Table 4;
- $TEC_{GRAPHICS}$ is the Discrete Graphics allowance specified in Table 4, if applicable;
- TEC_{WOL} is the Wake-on-LAN allowance specified in Table 4, if applicable;
- $TEC_{INT_DISPLAY}$ is the Integrated Display allowance for Integrated Desktops specified in Table 3, if applicable; and
- TEC_{EEE} is the Energy Efficiency Ethernet incentive for Desktops specified in Table 3, if applicable, per IEEE 802.3az compliant (Energy Efficient Ethernet) Gigabit Ethernet port.

Table 4: Adder allowances for Thin Clients

Equation 2: TEC Calculation (E_{TEC}) for Desktop, Integrated Desktop, and Thin Client

$$E_{TEC} = 8760 + 1000 \times (POFF \times TOFF + PSLEEP \times TSLEEP + PLONG_IDLE \times TLONG_IDLE + PSHORT_IDLE \times TSHORT_IDLE)$$

Where:

- $POFF$ = Measured power consumption in Off Mode (W)
- $PSLEEP$ = Measured power consumption in Sleep Mode (W)
- $PLONG_IDLE$ = Measured power consumption in Long Idle Mode (W)
- $PSHORT_IDLE$ = Measured power consumption in Short Idle Mode (W); and
- $TOFF$, $TSLEEP$, $TLONG_IDLE$, and $TSHORT_IDLE$ are mode weightings as specified in Table 5

Table 5: Mode weightings for Desktops, Thin Clients, and Integrated Desktop Computers
Testing only needs to cover the energy consumption requirements and the power supply requirements of that program. The product does not need to be ENERGY STAR certified to be approved for TCO Certified.

Measured energy consumption according to ENERGY STAR® , as well as Typical Energy Consumption (TEC) and the allowed maximum consumption (TEC_MAX) for each category (I1-I2, D1-D2, 0-2 or Thin Clients) must be submitted to TCO Certified Portal, together with the application.

Exceptions and special requirements

All exceptions and special requirements, test methods etc. that are accepted by ENERGY STAR are also accepted by TCO Development.

Products that are covered by another ENERGY STAR product specification must be tested according to that specification.

Draft 2

Visual ergonomics

Good visual ergonomics is a very important aspect of quality that can also have a direct effect on the health, comfort and productivity of the user. Good ergonomics, such as a high quality display image, can also influence our productivity and extend the usable life of a product. In this way, ergonomic design can also offer sustainability benefits.

In developing criteria for visual ergonomics, the possible health effects of various parameters have been taken into account. Other features that characterise high quality displays have also been in focus when developing these criteria.

TCO Development used three main methodologies to determine suitable levels and test methods for the visual ergonomics criteria:

1. Acceptable visual levels, as determined by scientific research.
2. Statistics from tests carried out in accordance with TCO Development, ISO, MPR regulations and from specialized VDU tests.
3. Manufacturers' knowledge and experience, which is invaluable. Manufacturers, consumer groups and other organisations with interests in the visual ergonomics field have contributed a great deal of valuable information and ideas throughout the development process.

5.2 Display resolution

Background

Image quality is negatively affected by a low fill factor, visible “jaggies” and poor rendering of details. All of these are related to the resolution of the display. For display resolution characteristics, it is important to take the viewing distance into account.

Definition

A pixel is the smallest addressable imaging element of the display panel capable of reproducing a full range of luminance and colors.

Applicability

Displays and all-in-one PCs.

References

5.3-5.5.

5.2.1 Mandate

~~The display panel should~~ [Display panels <60” must](#) have a pixel density of at least 70 PPI -

~~Submit and~~

[Display panels >60” must have a resolution of at least 8.3 MP \(4K\)](#)

The following ~~together with the application is submitted~~ to TCO Development:

- A copy of the test report(s), and a copy of the verification report(s) from a verifier approved by TCO Development.

[The following is submitted to TCO Development and may be published:](#)

- The pixel density must be reported in TCO Certified Portal.

5.2.2 Clarification

~~The defined 70 PPI gives a reasonable image quality at a~~ viewing distance ~~in this criteria document is of~~ 80 cm, which can be regarded as a normal viewing distance to a ~~typical~~ display monitor on a desktop workspace, based on anthropometric data. [Very large displays \(>60”\)](#)

[are often those used in conference rooms or for multiple viewers. In these situations, the viewing distance is often more than 80cm, so 4k resolution should be enough in most cases.](#)

Preparations for testing

No specific preparation of the product is needed.

Equipment

Calibrated ruler for the diagonal measurement. Product manual or similar information about the display resolution.

Test method

The maximum resolution and size of the display panel can be found in the manual or in a similar information document from the manufacturer. Verify the diagonal distance in inches rounded to one decimal and calculate the PPI.

Test evaluation

The pixel density (PPI, pixels per inch) should be calculated as following:

$$PPI = \frac{\sqrt{\textit{horizontal pixels}^2 + \textit{vertical pixels}^2}}{\textit{the diagonal of the panel in inches}}$$

Overall uncertainty

Measurement uncertainty in diagonal measurement is $\leq \pm 2\text{mm}$. Product data information is sufficient.

See 9.1.10

5.3 Correlated color temperature

Background

Physical measurements of color stimuli can only give an indication of the color appearance in a practical situation. The color of the frame, the spectral composition of the lighting, the color of various areas in the visual field, and the complexity of brightness variations in the visual field all influence the color appearance of a display image.

It is important to be able to set a color temperature that represents average daylight. It will be intuitive to most users to have their document background and photo editing in this color temperature as this is a light source that users will be exposed to daily. Average atmospheric filtered daylight has a correlated color temperature of approximately 6500K and is reproduced according to a number of standards such as D65, sRGB and ITU Rec 709, which are widely used in photo and video editing.

Definition

The correlated color temperature is a measure of the perceived screen color expressed in Kelvin (K).

Applicability

Non monochromatic displays and all-in-one PCs with backlit or light emitting pixels.

References

5.4, 5.5, 5.10, 5.19-5.22, 5.23, 5.26, 5.27, 5.30-5.33, 5.34-5.40.

5.3.1 Mandate

The product's default preset correlated color temperature may have any name but must have a color difference $\Delta u'v' \leq 0.012$ when compared to CIE u' and v' chromaticity coordinates for D65.

Submit The following ~~together with the application~~ **is submitted** to TCO

Development:

- A copy of the test report(s), and a copy of the verification report(s) from a verifier approved by TCO Development.
- The measured values must be reported in TCO Certified Portal.

5.3.2 Clarification

Preparations for testing

- All necessary preparations described in 9.1 and 9.2 must be done.
- A TCO Certified default test image, as shown in figure 9.1.7, must be used for this measurement.

Equipment

Spectro-radiometer capable of presenting CIE u' and v' chromaticity coordinates with at least three decimals.

Test method

The spectral properties at the centre of the measurement area must be measured with a spectroradiometer. The spectral data must then be processed, which is normally done directly in the instrument's microprocessor, to give chromaticity coordinates. In this case, the CIE coordinates u' and v' are needed for the test evaluation and are often presented directly by the spectro-radiometer used.

Test evaluation

CIE $u'v'$ chromaticity coordinates for D65.

u'	v'
0,1979	0,4683

If the spectro-radiometer used only can produce CIE 1931 x and y chromaticity coordinates, these can be transformed to u' and v' chromaticity coordinates by using the formulae in the CIE Publication 15.2 (reference 5.26). The relevant CIE material – conversion formulae and tabulated data for u'_{cct} and v'_{cct} – can also be found on tcocertified.com.

The resulting color difference calculation must be presented to 3 decimal places.

Overall uncertainty

$\leq \pm 0.003$ in u' and v' .

See 9.1.10

5.4 Color gamut

Background

Accurate color rendering is important when realistic color images or color presentations are presented on the display screen. Poor color rendering can lead to poor readability and misinterpretation.

Definition

The color characteristics of a display are based on the visual appearance of the primary color stimuli of the display, the R, G, B-stimuli. The color gamut of a device or process is that portion of the color space that can be represented or reproduced.

Applicability

Non-monochromatic displays and all-in-one PCs with backlit or light emitting pixels.

References

5.5, 5.19-5.23, 5.26, 5.27, 5.30-5.34, 5.37-5.40.

5.4.1 Mandate

The following mandates must be met:

1. The minimum color triangle must be $\geq 29\%$.
2. The following tolerances to the sRGB coordinates:

	Red		Green		Blue	
Coordinate	u'	v'	u'	v'	u'	v'
Requirement	≥ 0.411	≥ 0.503	≤ 0.140	≥ 0.548	≥ 0.150	≤ 0.210

Submit The following ~~together with the application~~ **is submitted** to TCO

Development:

1. A copy of the test report(s), and a copy of the verification report(s) from a verifier approved by TCO Development.
2. The measured values must be reported in TCO Certified Portal.

5.4.2 Clarification

The u' and v' chromaticity coordinates of the primary colors red (R), green (G) and blue (B) of the screen must aim at values given in international IEC, EBU and ITU standards. The u' and v' chromaticity coordinates of the primary colors R, G and B form a triangle in the CIE 1976 uniform chromaticity scale diagram. The larger the area of the triangle, the more saturated and the wider the range of colors the screen is capable of presenting if the same numbers of color bits are used. The relative color gamut calculation in this document is expressed as a percentage of the total CIE 1976 uniform chromaticity scale diagram. However, it is also important that the u' and v' for red, green and blue are accurate enough to present as true colors as possible.

Preparations for testing

- All necessary preparations described in 9.1 and 9.2 must be done.
- A TCO Certified default test image, as shown in figure 9.1.7, must be used for this measurement.
- The measurement area must have each of the following RGB settings: (255, 0, 0) for red, (0, 255, 0) for green, (0, 0, 255) for blue.

Equipment

Spectroradiometer with a capacity to present u' and v' coordinates with at least 3 decimals.

Test method

The instrument must be directed orthogonally towards the different test square centers at the measurement distance described in 9.2.5. Measure the chromaticity coordinates at the center of the measurement area for each color setting specified above, or alternatively, the larger measurement area image (80% of the active screen area) described in 9.1.7 may be used for these measurements. Change the color of the area for each measurement.

Reference color coordinates are based on sRGB: Red ($u' 0.451, v' 0.523$), Green ($u' 0.125, v' 0.563$), Blue ($u' 0.175, v' 0.158$) which corresponds to 33.3% of the total CIE 1976 uniform chromaticity scale diagram (100% sRGB and 87% Adobe RGB).

Test evaluation

Mandate 1

Calculate the color gamut using the equation below.

$$A (\%) = 256.1 \times |(u'R - u'B)(v'G - v'B) - (u'G - u'B)(v'R - v'B)|$$

The indexes R, G and B are short for Red, Green and Blue.

Example: The following reading gives a gamut of $A = 31.65\%$

Red $u'/v' = 0,436/0,526$

Green $u'/v' = 0,132/0,572$

Blue $u'/v' = 0,181/0,158$

Mandate 2

The recorded chromaticity coordinates u' and v' for the Red, Green and Blue squares must be reported. The u' and v' must be presented to 3 decimal places.

Overall uncertainty

$\leq \pm 0.003$ in u' and v' for red and green.

$\leq \pm 0.007$ in u' and v' for blue.

See 9.1.10

5.5 Color uniformity

Background

The human visual system is very sensitive to changes in color hue in white and gray areas. White and gray color hues also serve as reference colors on the screen, that affect how all other colors are perceived. Patches of color variation on an active white or gray screen may reduce the contrast, be disturbing and affect readability, color rendering and color differentiation.

Definition

The color uniformity of a display is the capability to maintain the same color on any part of the screen.

Applicability

Non monochromatic displays and all-in-one PCs with backlit or light emitting pixels.

References

5.4, 5.5, 5.18, 5.23, 5.26, 5.27, 5.28, 5.29, 5.34, 5.40.

5.5.1 Mandate

The maximum color deviation between measured active areas on the screen that are intended to present the same color must be $\Delta u'v' \leq 0.012$.

Submit The following ~~together with the application~~ is submitted to TCO

Development:

1. A copy of the test report(s), and a copy of the verification report(s) from a verifier approved by TCO Development.
2. The measured values must be reported in TCO Certified Portal.

5.5.2 Clarification

Preparations for testing

- All necessary preparations described in 9.1 and 9.2 must be done.
- The entire active area of the screen must be white and the display color setting must be RGB 255, 255, 255.

Equipment

Spectroradiometer with a capacity to present u' and v' coordinates with at least 3 decimals.

Test method

The color uniformity must be measured orthogonally to the display screen plane at nine points. The four corner positions (1, 3, 7 and 9) are measured 1° from the edges of the screen as shown in *luminance uniformity 1*. The 4 side positions (2, 4, 6 and 8) are measured on the middle of the side 1° from the edge. These measurement points have a $1/2^\circ$ margin to the edges if the measurement area of the instrument is 1° (see figure *luminance uniformity 1* (section 5.9.2)). Finally, the center position (5) is measured.

In addition to the nine default positions, the color uniformity must also be evaluated visually by the technician in order to find areas where the color varies the most. If a significant difference within the 1° from the edge area is found, these measuring points must also be measured and used to evaluate the color uniformity. The conditions for color measurement in the corner positions and the distribution of other measurement points are illustrated in figure *luminance uniformity 1*.

Test evaluation

$\Delta u'v'$ according to the CIE (1976) uniform chromaticity scale diagram must be calculated for each measured position using the formula:

$$\Delta u'v' = \sqrt{(u'_A - u'_B)^2 + (v'_A - v'_B)^2}$$

where A and B are the two points found to have the largest color difference between them.

The largest difference in $u'v'$ value must be reported.

The result must be presented to 3 decimal places.

The evaluation procedure is exemplified below:

- Make a table of color chromaticity values for each measured position.

Measurement position no.	u'	v'
1	0.190	0.447
2	0.186	0.441
3	0.186	0.437
-	-	-
n-1	0.185	0.434

n	0.186	0.432
Largest difference	0.005 in this example	0.015 in this example

- The largest u' difference, $\Delta u'$, is 0.005 (between 0.190 and 0.185) at measurement positions 1 and n-1.
- The largest v' difference, $\Delta v'$, is 0.015 (between 0.447 and 0.432) at measurement positions 1 and n.
- Since $\Delta v'$ (= 0.015) is much larger than $\Delta u'$ (= 0.005), the $\Delta v'$ value must be used for the calculation of $\Delta u'v'$.
- The corresponding two pairs of u' and v' to be used for the calculation are thus the values found at position 1 and position n and thus become the values used for points A and B such that $u'_1 = u'_A = 0.190$ and $v'_1 = v'_A = 0.447$ for point A in this example and $u'_n = u'_B = 0.186$ and $v'_n = v'_B = 0.432$ for point B in this example.

Hence $\Delta u'v' = \sqrt{0.000016 + 0.000225} = 0.01552$, which must be reported as 0.016.

Overall uncertainty

$\leq \pm 0.003$ in u' and v' .

See 9.1.10

5.6 Color uniformity – angular dependence

Background

The human visual system is very sensitive to changes in color hue in white and gray areas. White and gray color hues also serve as reference colors on the screen, that affect how all other colors are perceived. Angular-dependent color variations on an active white or gray screen may be disturbing and affect readability, color rendering and color differentiation.

Definition

The white color uniformity – angular dependence of a display is the capability of the display to maintain constant white color over the screen surface depending of the direction from which the screen is viewed.

Applicability

Non monochromatic displays and all-in-one PCs with backlit or light emitting pixels.

References

5.4, 5.18, 5.23, 5.26-5.29, 5.34.

5.6.1 Mandate

In landscape mode, the $\Delta u'v'$ of white color between areas on the left side and the right side of the screen when it is positioned at $+30^\circ$ and at -30° horizontally to the screen normal (rotated around the vertical axis through the center of the screen), must be $\Delta u'v' \leq 0.024$.

Submit The following ~~together with the application~~ is submitted to TCO

Development:

- A copy of the test report(s), and a copy of the verification report(s) from a verifier approved by TCO Development.
- The measured value must be reported in TCO Certified Portal.

5.6.2 Clarification

Preparations for testing

- All necessary preparations described in 9.1 and 9.2 must be done.
- The screen background must be RGB 102,102,102.

- Chromaticity coordinates u' and v' must be measured at three different positions on the screen as shown in figure *color uniformity - angular dependence 1*, below. Each measurement position must consist of white RGB 255, 255, 255 areas with a size that is 4% of the active screen size.
- The spectro-radiometer must be positioned and directed orthogonally to the screen center-point as described in 9.2.5.

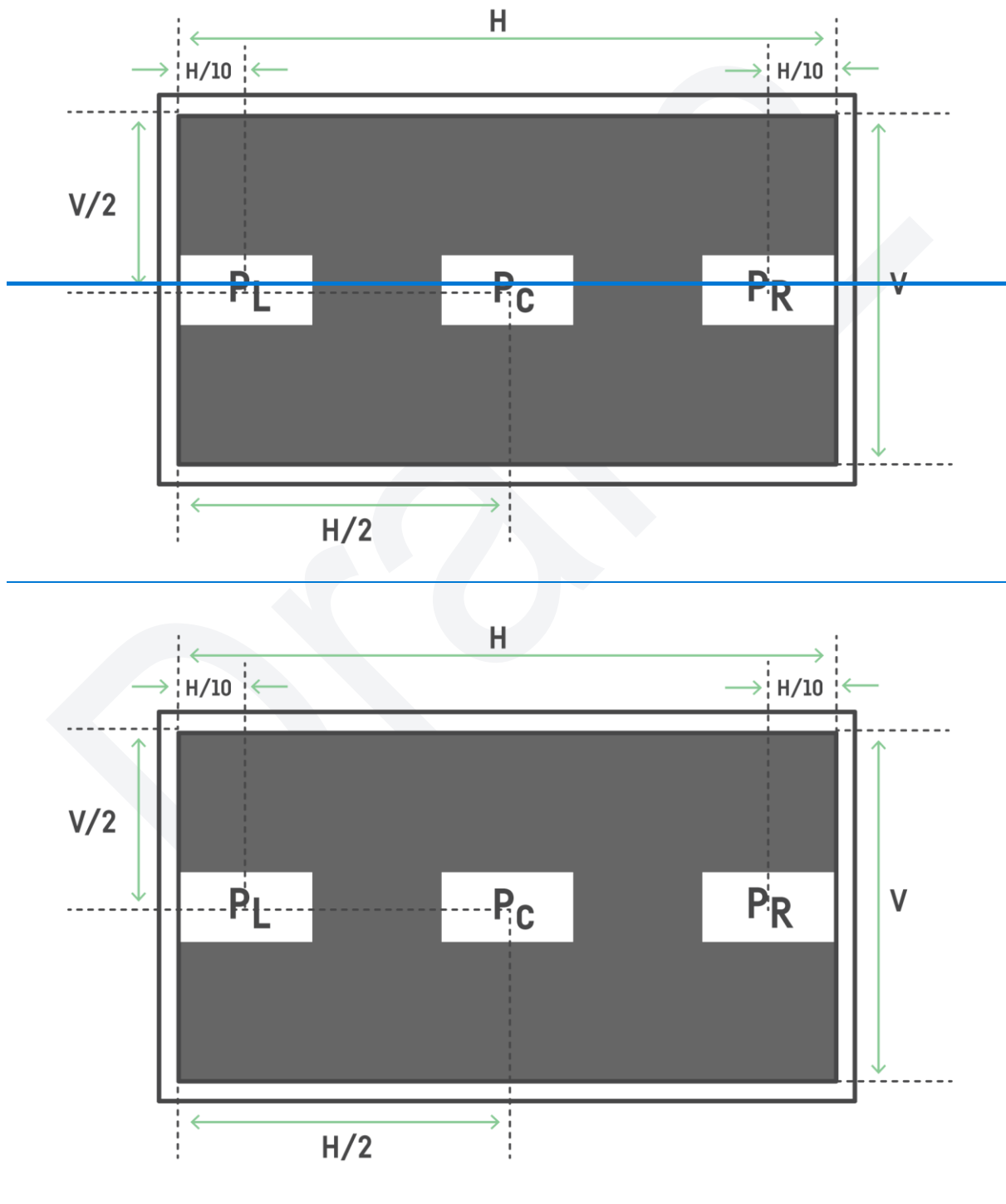

Figure *color uniformity - angular dependence 1*. Measurement positions for color uniformity-angular dependence.

Equipment

Spectroradiometer with a capacity to present u' and v' coordinates with at least 3 decimals.

Test method

- The spectro-radiometer must always be directed towards a measurement point and rotated around a fixed vertical axis, (or horizontal axis for the tilt measurement) through the focal point of the front lens from the distance described in 9.2.5.
- The spectro-radiometer must be turned towards positions P_L and P_R and focused. The color coordinates at positions P_L and P_R ($u'_{PL/0}$, $v'_{PL/0}$ and $u'_{PR/0}$, $v'_{PR/0}$ respectively) must be recorded.
- The screen must then be rotated +30 degrees around a vertical axis through the screen's center-point and the chromaticity coordinates at positions P_L , P_R , ($u'_{PL/+30}$, $v'_{PL/+30}$ and $u'_{PR/+30}$, $v'_{PR/+30}$ respectively) must be recorded.
- The screen must finally be rotated -30 degrees around a vertical axis through the screen's center-point and the chromaticity coordinates at positions P_L , P_R , ($u'_{PL/-30}$, $v'_{PL/-30}$ and $u'_{PR/-30}$, $v'_{PR/-30}$ respectively) must be recorded.
- Pivot screens must only be measured in the usual landscape mode.

Test evaluation

$\Delta u'v'$ according to the CIE (1976) uniform chromaticity scale diagram must be calculated for each measured position using the formula:

$$\Delta u'v' = \sqrt{(u'_A - u'_B)^2 + (v'_A - v'_B)^2}$$

where A and B are the two points found to have the largest color difference between them.

The largest difference in $u'v'$ value must be reported

The result must be presented to 3 decimal places.

The evaluation procedure is exemplified below:

- Make a table of chromaticity values for each measurement position and calculate $\Delta u'v'$ for +30° for and -30°.

Measurement position no.	Example value u'	Example value v'
PL /+30	0.190	0.447
PR /+30	0.187	0.442

Difference at +30°	0.003	0.005
$\Delta u'v'$ at +30°	0.0059	
Measurement position no.	Example value u'	Example value v'
PL /-30	0.182	0.436
PR /-30	0.189	0.432
Difference at -30°	0.007	0.004
$\Delta u'v'$ at -30°	0.0081	
Largest difference $\Delta u'v'$	0.0081 in this example	

The largest calculated $\Delta u'v'$ difference is 0.0081 when the screen is rotated -30°. The test value to be reported is this value, reported to 3 decimal places, thus 0.008.

Overall uncertainty

$\leq \pm 10\%$ in luminance.

$\leq \pm 0.003$ units for u' and v' .

$\leq \pm 0.3^\circ$ in rotation angle.

See 9.1.10

5.7 Color grayscale linearity

Background

A well-tuned color grayscale is the basis for good color rendering of the screen. This is measured by comparing steps in a grayscale on the screen. To enable correct color interpretation, each grayscale step should have similar color hues. To avoid confusion for the user, only the luminance should vary.

Definition

Color grayscale linearity is the capability of the screen to maintain the same u',v' coordinates of a grayscale pattern at all grayscale levels. Only the luminance should change from one grayscale step to the next.

Applicability

Non monochromatic displays and all-in-one PCs with backlit or light emitting pixels..

References

5.4, 5.6, 5.18, 5.23, 5.26-5.29.

5.7.1 Mandate

$\Delta u'v' \leq 0.020$ between 28 evenly distributed grayscale levels combinations.

Table *color grayscale linearity 1*

Grayscale	Maximum u'v' difference							
	255	225	195	165	135	105	75	45
255	0							
225	0.020	0						
195	0.020	0.020	0					
165	0.020	0.020	0.020	0				
135	0.020	0.020	0.020	0.020	0			
105	0.020	0.020	0.020	0.020	0.020	0		
75	0.020	0.020	0.020	0.020	0.020	0.020	0	
45	0.020	0.020	0.020	0.020	0.020	0.020	0.020	0

Submit The following ~~together with the application~~ is submitted to TCO

Development:

1. A copy of the test report(s), and a copy of the verification report(s) from a verifier approved by TCO Development.
 2. The largest $\Delta u'v'$ measurement must be reported in TCO Certified Portal.
-

Draft 2

5.7.2 Clarification

Preparations for testing

- All necessary preparations described in 9.1 and 9.2 must be done.
- A TCO Certified default test image, as shown in figure 9.1.7, must be used for this measurement.
- The measurement area must have a size that is 4% of the active screen size and have the following RGB settings: R=G=B= 255, 225, 195, 165, 135, 105, 75, 45.

Equipment

Spectroradiometer with a capacity to present u' and v' coordinates with at least 3 decimals.

Test method

The instrument must be directed orthogonally towards the center of the measurement area, from the distance described in 9.2.5. Measure the chromaticity coordinates at the center of the measurement area for each grayscale step specified above. Change the grayscale of the area for each measurement.

Test evaluation

A spreadsheet is available on tco certified.com, which will calculate the $\Delta u' v'$ differences between all the grayscale levels according to the equation:

$$\Delta u' v' = \sqrt{(u'_A - u'_B)^2 + (v'_A - v'_B)^2}$$

Fill in the chromaticity values of u' and v' for each measured grayscale step into the corresponding cells of the spreadsheet.

Overall uncertainty

$\leq \pm 10\%$ in luminance.

$\leq \pm 0.003$ units for u' and v' .

See 9.1.10

5.8 Luminance level

Background

Poor screen luminance can lead to low contrast, poor readability and color discrimination, which may cause misinterpretations and eye strain. Therefore, it is important that the luminance levels can be set both high and low enough, with respect to the ambient lighting.

Definition

Luminance being emitted from a particular area is a measure of the luminous intensity per unit area of light travelling in a given direction and falls within a given solid angle.

The unit of luminance is candela per square meter (cd/m^2)

Applicability

Displays and all-in-one PCs with backlit or light emitting pixels.

References

5.3-5.5, 5.7-5.11.

5.8.1 Mandate

The following conditions must be fulfilled:

- The luminance at default setting must be $\geq 150 \text{ cd}/\text{m}^2$
- The maximum luminance must be $\geq 200 \text{ cd}/\text{m}^2$
- The minimum luminance must be $\leq 100 \text{ cd}/\text{m}^2$

Submit The following ~~together with the application~~ is submitted to TCO

Development:

- A copy of the test report(s), and a copy of the verification report(s) from a verifier approved by TCO Development.
- The maximum and minimum luminance must be reported in TCO Certified Portal

5.8.2 Clarification

Preparations for testing

- All necessary preparations described in 9.1 and 9.2 must be done.

- The TCO Certified default test image with an 18 step grayscale as shown in figure *Luminance level 1* must be used for luminance level measurement.

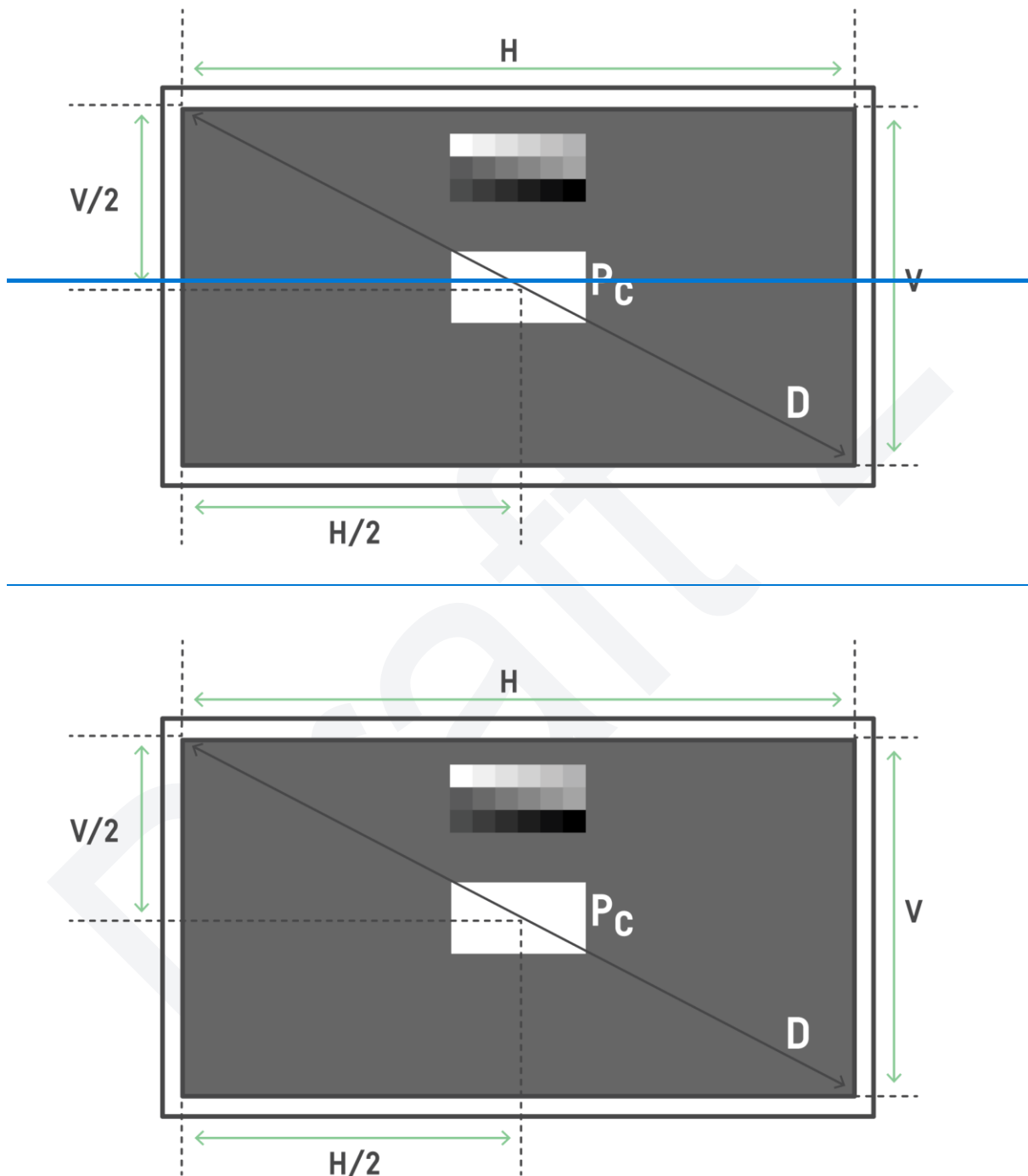

Figure *Luminance level 1*. TCO Certified default test image with the 18-step grayscale inserted.

- The measurement position P_C must be at the center of the measurement area without line borders, have an RGB setting of 255, 255, 255, and be positioned at the center of the screen. The background must be RGB 102,102,102.
- Reset the display to its default setting. Check that the luminance is ≥ 150 cd/m².

The following evaluations must be carried out orthogonally to the screen surface.

- To achieve the maximum luminance, proceed as follows:
Use the TCO Certified default test image with an 18 step grayscale pattern presented on the screen. From the default setting, adjust the controls on the display to achieve as high luminance as possible with an acceptable image quality. The image quality is considered acceptable if at least 15 of the 18 grayscale steps are visible. Check that the display has a luminance of ≥ 200 cd/m².
- Reset the display to its default setting. From the default setting, adjust the controls on the display to achieve as low luminance as possible with an acceptable image quality. The image quality is considered acceptable if at least 15 of the 18 grayscale steps are visible. Check that the display has a luminance of ≤ 100 cd/m².
- If it difficult to visually determine if 15 of the 18 grayscale steps are visible, then the display must conform with the *grayscale gamma curve* criteria in the max and min luminance setting.
- After this test is completed the display must be put back in its default mode by pressing a reset button or similar. After each reset, the display has to stabilize before other test measurements are made.

Equipment

Luminance meter or spectroradiometer.

Test method

The luminance at the center of the white measurement area must be measured with the luminance meter directed orthogonally to the measurement area as described in 9.2.5.

Test evaluation

The measured luminance is the required value. The luminance must be reported with no decimal places.

The measured luminance, contrast and brightness settings for all conditions must be noted in the test report. The preset CCT in default setting must also be noted.

Overall uncertainty

$\leq \pm 10\%$ in luminance.

See 9.1.10

Draft 2

5.9 Luminance uniformity

Background

Poor luminance uniformity can locally affect the contrast and consequently the readability of information on the display. The areas of deviating luminance can have different sizes and cause varying contour sharpness.

Definition

Luminance uniformity is the capacity of the display to maintain the same white luminance level over the whole active screen area. The luminance uniformity is defined as the ratio of maximum to minimum luminance within the fully active screen area.

Applicability

Displays and all-in-one PCs with backlit or light emitting pixels.

References

5.3-5.10, 5.12-5.15.

5.9.1 Mandate

Luminance variation across the active screen, $L_{\max} : L_{\min}$ must be ≤ 1.50 .

Submit The following ~~together with the application~~ is submitted to TCO

Development:

- A copy of the test report(s), and a copy of the verification report(s) from a verifier approved by TCO Development.
- The Luminance variation must be reported in TCO Certified Portal

5.9.2 Clarification

Preparations for testing

- All necessary preparations described in 9.1 and 9.2 must be done.
- The entire active area of the screen must be white and the display color setting must be RGB 255, 255, 255.

Equipment

Luminance meter or spectroradiometer.

Test method

The luminance must be measured orthogonally to the display screen plane at nine points. The four corner positions (1, 3, 7 and 9) are measured 1° from the edges of the screen as shown in figure *luminance uniformity 1*. The four side positions (2, 4, 6 and 8) are measured on the middle of the side, 1° from the edge. Finally, the center position (5) is measured. This means that all measurement points have $1/2^\circ$ marginal to the edges if the measurement area of the instrument is 1° .

The luminance uniformity must also be evaluated visually by the technician in order to find any dark or bright areas outside of the nine default positions. If a significantly bright or dark area is found, these measuring points must also be measured and used to evaluate the luminance uniformity.

The conditions for luminance measurement in the corner positions and the distribution of other measurement points are illustrated in figure *luminance uniformity 1*.

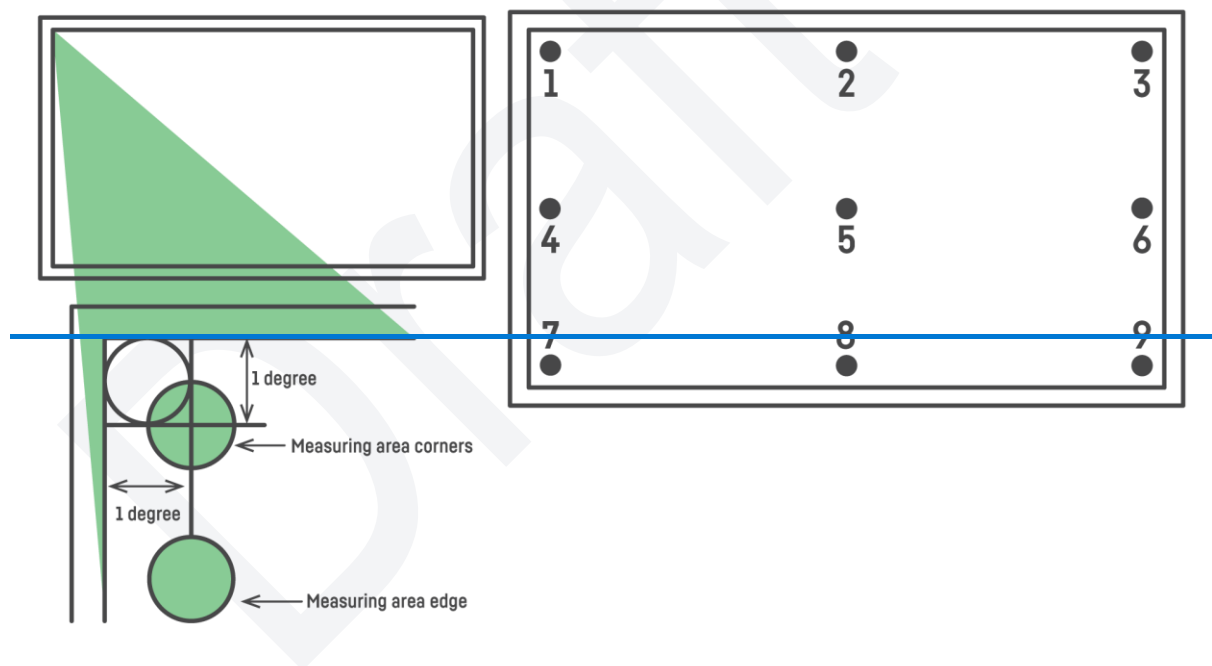

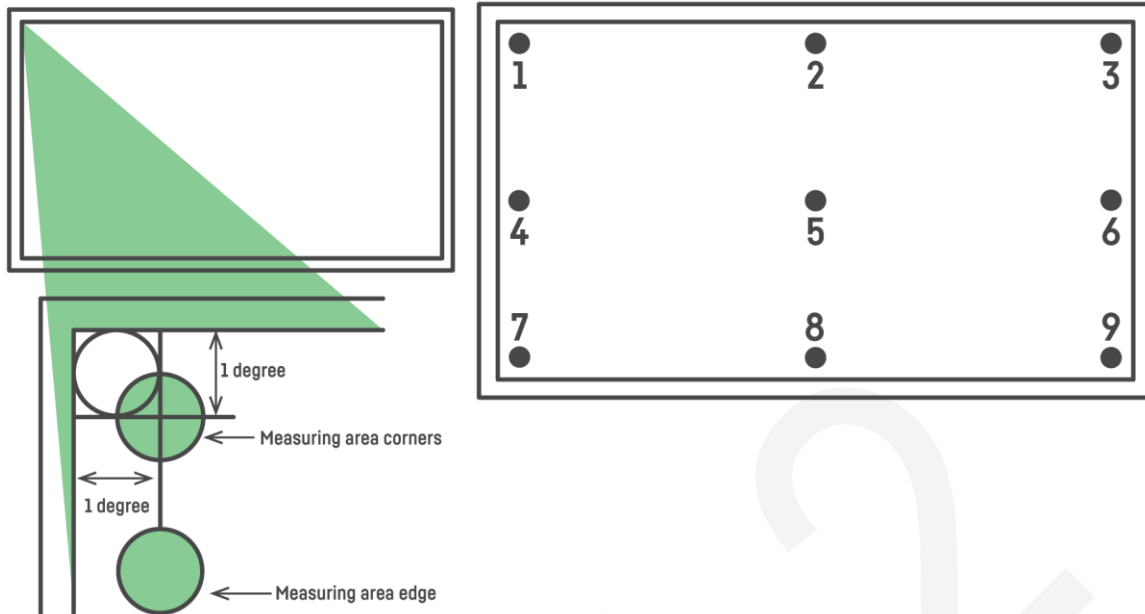

Figure *luminance uniformity 1* Measurement positions for the measurement of luminance and color uniformity.

Test evaluation

The luminance uniformity must be reported as the ratio between the highest and the lowest measured luminance values. The result must be presented to 2 decimal places.

Overall uncertainty

$\leq \pm 10\%$ in luminance.

$\leq \pm 0.1$ unit in luminance uniformity.

See 9.1.10

5.10 Luminance uniformity – angular-dependence

Background

The luminance of a display may be angular-dependent which means that screen luminance decreases when the display is viewed slightly from the side, either horizontally or vertically. This can have a negative effect on contrast and can affect the readability of the display.

Definition

Luminance uniformity – angular dependence, is the capacity of the display to maintain a certain luminance level irrespective of the viewing direction. The angular-dependent luminance uniformity is defined as the ratio of maximum luminance to minimum luminance in the specified measurement areas.

Applicability

Displays and all-in-one PCs with backlit or light emitting pixels.

References

5.7, 5.10-5.15.

5.10.1 Mandate

1. In landscape mode, when the screen is rotated around the vertical axis through the center of the screen the mean value of the L_{\max} to L_{\min} ratios at $\pm 30^\circ$ must be ≤ 1.73 .
2. In landscape mode, when the screen is rotated around the horizontal axis through the center of the screen, the largest value of the L_{\max} to L_{\min} ratios at $\pm 15^\circ$ must be ≤ 1.73 .

Submit The following ~~together with the application~~ is submitted to TCO

Development:

- A copy of the test report(s), and a copy of the verification report(s) from a verifier approved by TCO Development.

5.10.2 Clarification

Preparations for testing

- All necessary preparations described in 9.1 and 9.2 must be done.

- Luminance values must be measured at five different positions on the screen as shown in figure *luminance uniformity - angular-dependence 1*. Each measurement position must present white RGB 255, 255, 255 measurement areas (4% of the active screen size) without line borders.
- The background must be RGB 102,102,102.
- The luminance meter must be positioned and directed orthogonally to the screen center-point as described in 9.2.5

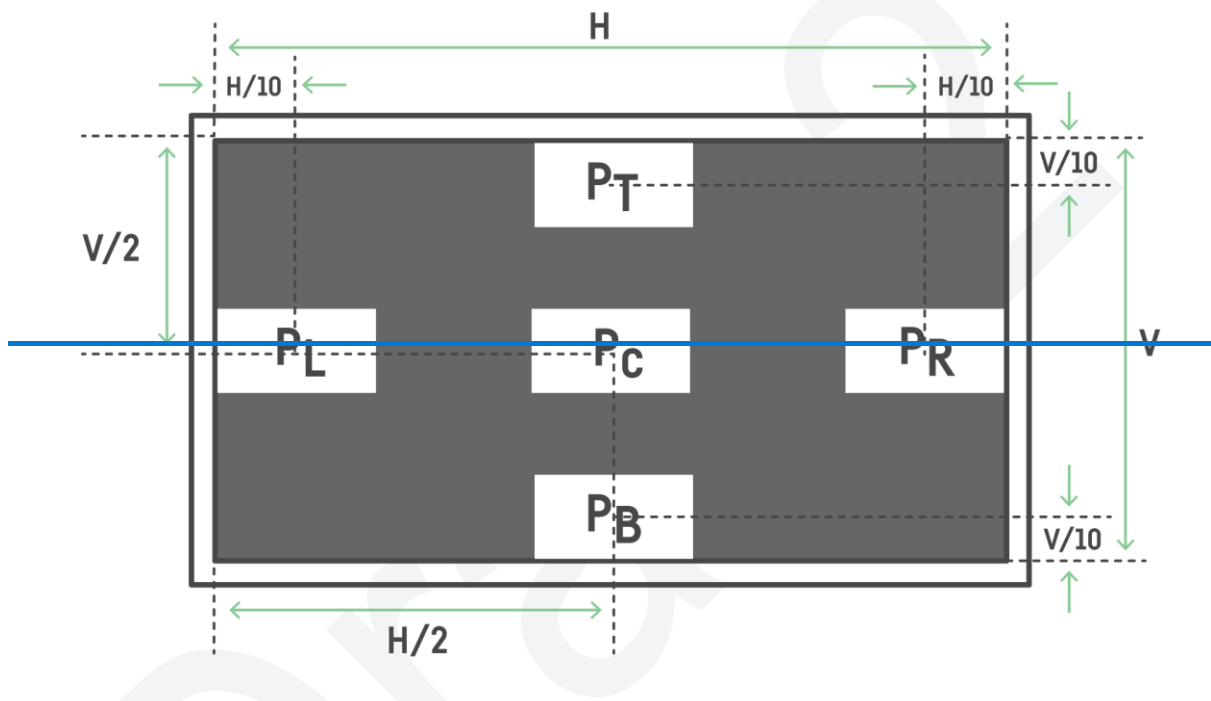

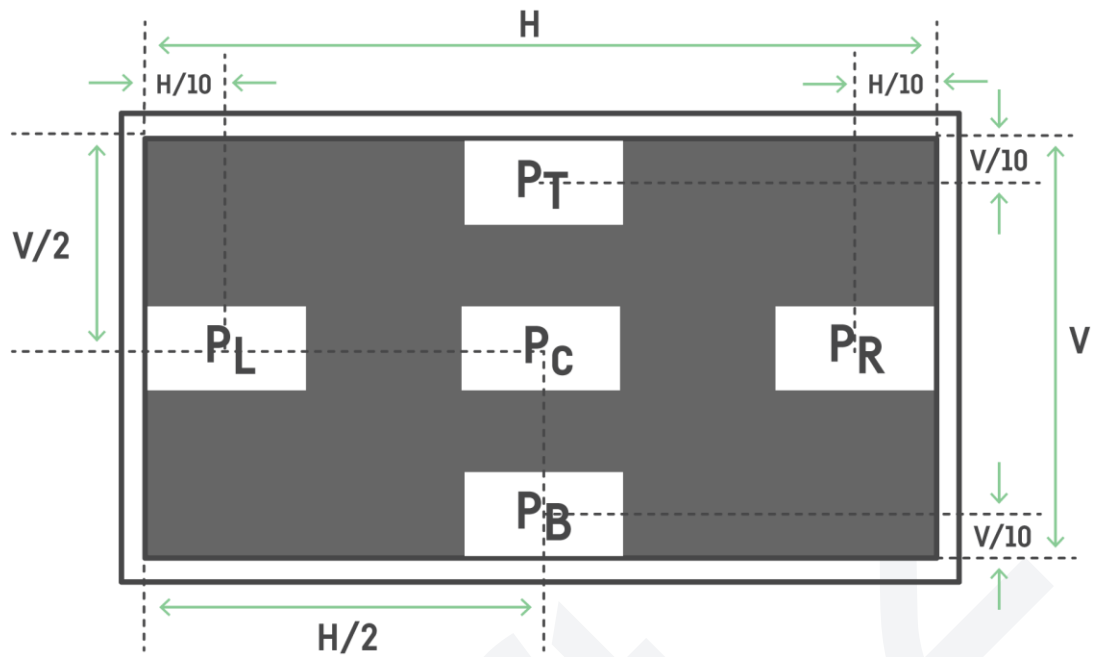

Figure: *luminance uniformity - angular-dependence 1*. Measurement positions for luminance uniformity - angular dependence.

Equipment

Luminance meter.

Test method (steps)

1. The luminance meter must always be directed towards a measurement point and rotated around a fixed vertical axis, (or horizontal axis for the tilt measurement) through the focal point of its front lens with a distance as described in 9.2.5.
2. In landscape mode the display must be rotated +30 degrees around a vertical axis through the display-glass center-point and the luminance at positions P_L and P_R ($L_{P_L/+30/0}$ and $L_{P_R/+30/0}$ respectively) must be recorded. See figure *luminance uniformity - angular-dependence 2*.
3. In landscape mode the display must then be rotated -30 degrees around the vertical axis through the display-glass center-point and the luminance at positions P_L and P_R ($L_{P_L/-30/0}$ and $L_{P_R/-30/0}$ respectively) must be recorded. See figure *luminance uniformity - angular-dependence 2*.
4. In landscape mode the display must then be tilted +15 degrees backwards around a horizontal axis through the display-glass center-point and the luminance at positions

P_T and P_B ($L_{PT/0/+15}$ and $L_{PB/0/+15}$ respectively) must be recorded. See figure *luminance uniformity - angular-dependence 3*.

5. In landscape mode the display must then be tilted -15 degrees forwards around a horizontal axis through the display-glass center-point and the luminance at positions P_T and P_B ($L_{PT/0/-15}$ and $L_{PB/0/-15}$ respectively) must be recorded. See figure *luminance uniformity - angular-dependence 3*.
6. The measurements to be carried out are summarized in table *luminance uniformity - angular-dependence 4*. The steps numbers in the step column correspond with the test method paragraphs.

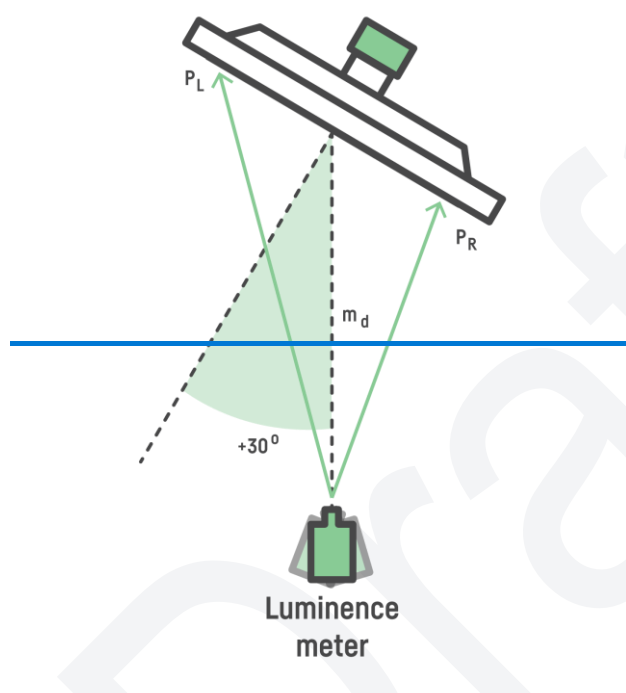

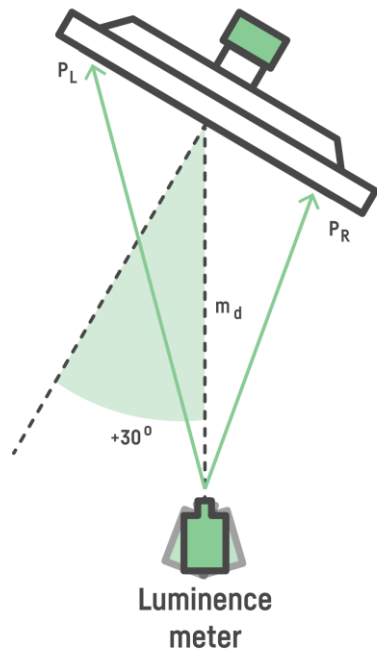
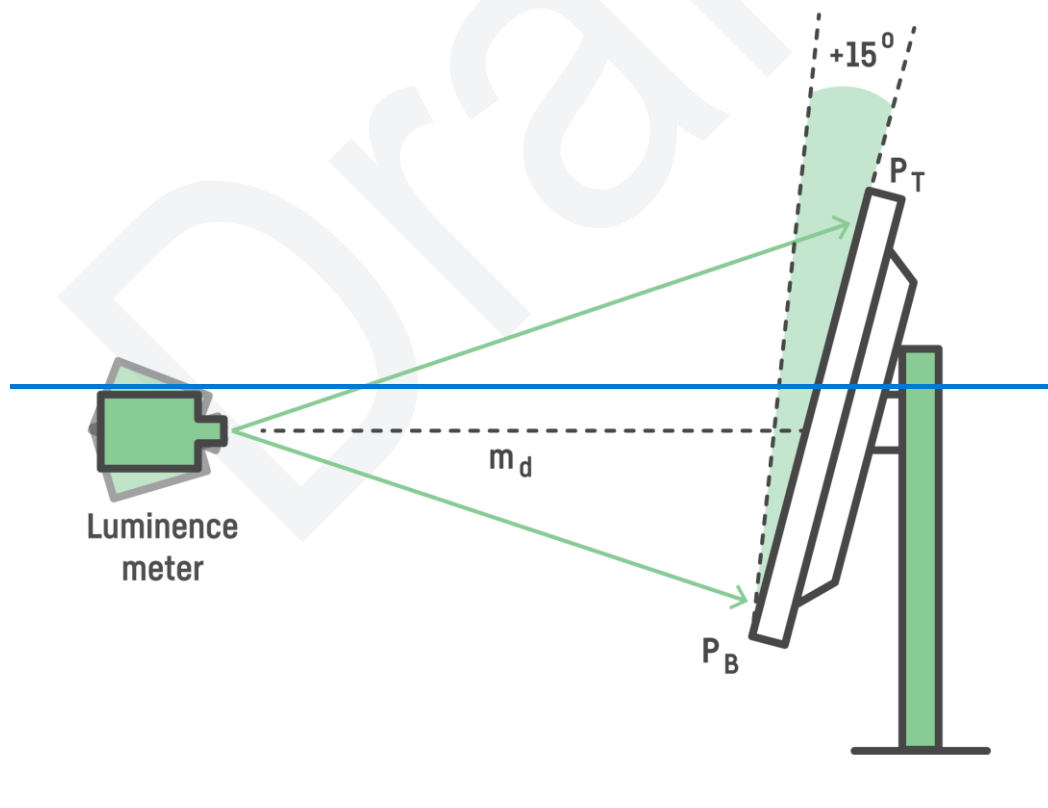

Figure *luminance uniformity - angular-dependence 2*. Top view of test set-up when the display is rotated ± 30 degrees. The + rotation is defined clockwise.



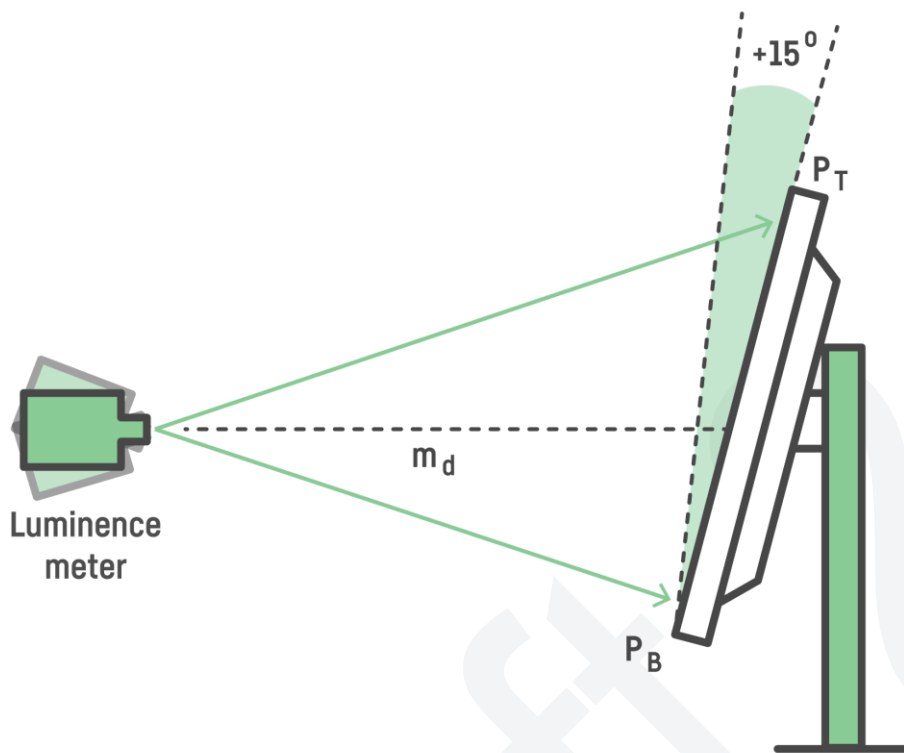

Figure *luminance uniformity - angular-dependence 3*. Side view of the test set-up when the display is tilted $\pm 15^\circ$. The + rotation is defined as backwards.

Table *luminance uniformity - angular-dependence 4*.

Test method step (reference above)	Landscape mode	Screen rotation	Screen tilt	Measuring points			
				P _L	P _R	P _T	P _B
Step 2	Horizontal direction (turned around vertical axis)	+30°	0°	X	X		
Step 3	Horizontal direction (turned around vertical axis)	-30°	0°	X	X		
Step 4	Backwards tilt = (turned around the horizontal axis)	0°	+15°			X	X
Step 5	Forwards tilt = (turned around the horizontal axis)	0°	-15°			X	X

Test evaluation

The luminance uniformity for angular dependence must be calculated as follows:

- In landscape mode, for the horizontal direction, (turned around the vertical axis) measurement presented in table *luminance uniformity - angular-dependence 4* (test step 2 and 3). A ratio between the two measured luminances must be calculated. This ratio, or its inverse if it has a higher value, must be reported as the requested L_{\max} to L_{\min} luminance uniformity in mandate 1. The requirement is on the mean value of the two ratios $+30^\circ$ and -30° . The result must be presented to 2 decimal places.
- In landscape mode, for the vertical direction (turned around the horizontal axis). Tilt backwards and tilt forwards $+15^\circ$ test step 4 and 5. A ratio between the two measured luminances must be calculated. This ratio, or its inverse if it has a higher value, must be reported as the requested L_{\max} to L_{\min} luminance uniformity in mandate 2. The requirement is on the larger of the two ratios $+15^\circ$ and -15° . The result must be presented to 2 decimal places.

Overall uncertainty

$\leq \pm 10\%$ in luminance.

$\leq \pm 0.3^\circ$ in rotation angle.

$\leq \pm 0.1$ unit in luminance uniformity.

See 9.1.10.

5.11 Luminance contrast – characters

Background

The degree of contrast is important for readability and for distinguishing one character from another.

Definition

Luminance contrast – characters are the capacity of the display to maintain a high luminance difference between a bright background and dark characters or parts of characters over the whole active area.

Luminance contrast – characters are expressed as the ratio of the L_{\max} to L_{\min} difference over the sum of L_{\max} and L_{\min} , in accordance with Michaelson's formula.

Applicability

Displays and all-in-one PCs with backlit or light emitting pixels.

References

5.3, 5.4, 5.10, 5.12-5.14, 5.16-5.18.

5.11.1 Mandate

The luminance contrast must be ≥ 0.70 measured orthogonally to the screen.

Submit The following ~~together with the application~~ is submitted to TCO

Development:

- A copy of the test report(s), and a copy of the verification report(s) from a verifier approved by TCO Development.
- The luminance contrast must be reported in TCO Certified Portal

5.11.2 Clarification

Preparations for testing

- All necessary preparations described in 9.1 and 9.2 must be done.
- A micro-photometer for luminance measurement must be aligned orthogonally to the display surface.

- The test images must be presented in a pixel matched way. (One program that does this up to 8-bit color is Microsoft Paint.)

Equipment

A micro-luminance meter such as an array photodetector capable of measuring luminance on structures ≤ 0.02 mm. Measurement requirements are given in section 9.2.2.

Draft 2

Test method

This measurement is a modified version of the measurements in IDMS 7.2 and IDMS 7.8.

By visual evaluation of the standard test measurement position, the technician must search for and locate visual stripes, or patches, that clearly influence the contrast of characters or even parts of characters. If patches with significantly lower contrast are found, they must be geometrically referenced from the upper left corner of the active image and the position must be reported in the test report. If no such position is found, the default test position is the center of the screen. If one position is found that does not fulfil the mandate, there is no need to make further measurements.

With an array or scanning light measuring device, obtain the luminance profile of the vertical black-pixel line and the corresponding white region. Obtain the net signal S as a function of distance with any background subtracted (this is the background inherent in the detector if a nonzero signal exists for no light input). A correction for veiling glare must be made. See the figure below for an illustration of the pixel configuration and data. 12 consecutive pixel rows must be used for integration in vertical direction to get a one-dimensional intensity signal.

Here, the 1-1-1-1 patterns must be used, i.e. the 6-groups with the highest resolution. Inside each group, the pattern with the worst measured performance must be chosen.

Perform a running window average (moving box-car filter) of the luminance profile where the averaging window width is as close as possible to the pixel pitch as rendered by the light measuring device. There should be at least ten or more detector pixels per display pixel. For example, if an array detector is used and with the magnification of the imaging lens there are 53.4 array pixels which cover the display pixel pitch, then the running average window width is 53 array pixels wide.

From the resulting modulation curve, determine (1) the net intensity level of the vertical black line $S_K = S_d - S_g$, where S_d is the minimum intensity level (dim) of the black line generated by the product, S_g is the ground level, and (2) the net intensity level of the white line $S_W = S_h - S_g$, where S_h is the maximum intensity level (high) of the white line generated by the product. Compute the resolution contrast ratio as, $C = (S_W - S_K) / (S_W + S_K)$.

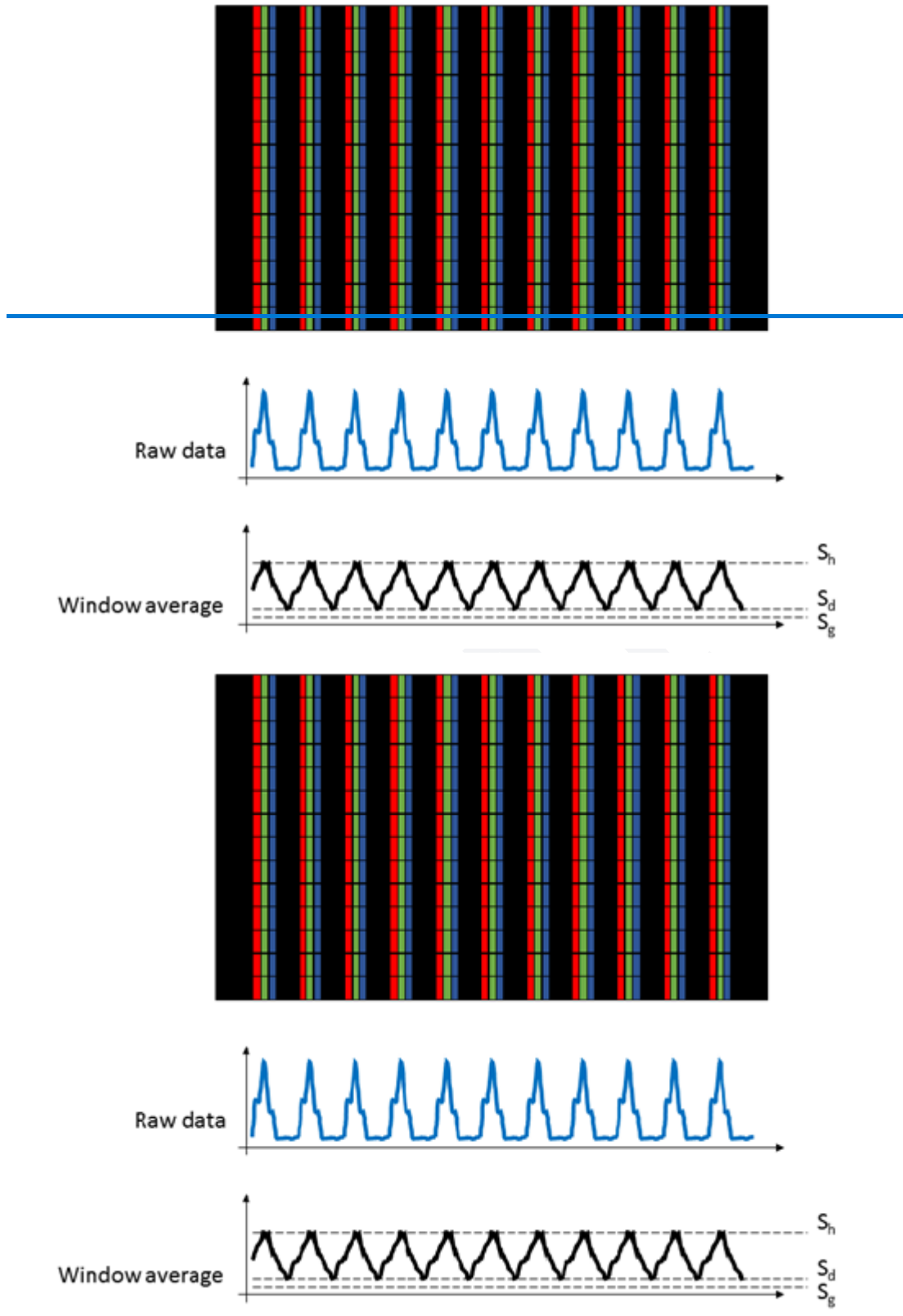

Figure *Luminance contrast - characters 1*: Measurement principle (from IDMS 7.2).

In summary:

$$S_K = S_d - S_g \quad (1)$$

$$S_w = S_h - S_g \quad (2)$$

$$C = (S_w - S_k) / (S_w + S_k)$$

Then perform the same operation but in vertical mode for the other set of grille patterns.
Record the contrast values for both directions.

Test picture: "WGrille pattern" with the same resolution as the display.

Test evaluation

- C must be ≥ 0.70 .
- The lowest luminance contrast found must be reported.
- The result must be presented to 2 decimal places.

Overall uncertainty

$\leq \pm 0.05$ in contrast.

The misalignment between the screen surface normal and the optical axis of the luminance meter must be $\leq 0.3^\circ$.

See 9.1.10

5.12 Luminance contrast – angular dependence

Background

For displays, the luminance and consequently the contrast of the display may be angular-dependent. The luminance variations can influence both the bright white and the dark areas of the screen, causing a change in contrast. This can have a negative effect on the readability of the display.

Definition

Luminance contrast – angular dependence, is the capability of the display to maintain the same white/black contrast regardless of the direction from which the screen is viewed.

Luminance contrast – angular dependence, is expressed as the ratio of the L_{\max} to L_{\min} difference over the sum of L_{\max} and L_{\min} , in accordance with Michaelson's formula. It is measured at two different angles.

Applicability

Displays and all-in-one PCs with backlit or light emitting pixels.

References

5.4, 5.12, 5.15-5.19.

5.12.1 Mandate

In landscape mode, the luminance contrast-angular dependence must be ≥ 0.80 at $\pm 30^\circ$ horizontally from the viewing direction (rotated around the vertical axis through the center of the screen).

Submit The following ~~together with the application~~ is submitted to TCO

Development:

- A copy of the test report(s), and a copy of the verification report(s) from a verifier approved by TCO Development.
- The luminance contrast-angular dependence must be reported in TCO Certified Portal.

5.12.2 Clarification

Preparations for testing

- All necessary preparations described in 9.1 and 9.2 must be done.
- A TCO Certified default test image, as shown in figure 9.1.7, must be used for this measurement.
- The measurement area must have each of the following RGB settings: (RGB 255, 255, 255) and (RGB 0, 0, 0).

Equipment

Luminance meter or spectroradiometer.

Test method

- The luminance meter must be positioned and directed orthogonally to the screen center-point as described in 9.2.5.
- The display must be rotated around a vertical axis through the screen front center, changing the azimuth angle to + 30°. The luminance of the white measurement area L_{W+30} and the luminance when the measurement area is black L_{K+30} at the center must be recorded.
- Finally the azimuth angle of the screen must be changed to -30° and the new measurements $L_{W/-30}$ and $L_{K/-30}$ taken.

Test evaluation

The luminance contrast values C_{+30} and C_{-30} must be calculated using the formula

$$C = \frac{L_W - L_K}{L_W + L_K}$$

Of C_{+30} and C_{-30} , only the lowest value must be reported as the luminance contrast.

Overall uncertainty

$\leq \pm 10\%$ in luminance.

See 9.1.10

5.13 Black level

Background

It is important that a display can produce a black level dark enough to show shadow details in pictures at high and low white luminance levels. The black level is also important for achieving a good contrast ratio.

Definition

Black level is the capacity of the display to maintain a good reproduction of black even when its white luminance is high.

Applicability

Displays and all-in-one PCs with backlit or light emitting pixels.

References

5.6.

5.13.1 Mandate

The luminance of black must be ≤ 2 cd/m² at a white luminance setting of ≥ 200 cd/m².

Submit The following ~~together with the application~~ is submitted to TCO

Development:

- A copy of the test report(s), and a copy of the verification report(s) from a verifier approved by TCO Development.
- The measured luminance must be reported in TCO Certified Portal.

5.13.2 Clarification

Preparations for testing

- All necessary preparations described in 9.1 and 9.2 must be done.
- The TCO Certified default test image with an 18-step grayscale as shown in figure *luminance level 1* or alternative the larger measurement area image also described in 9.1.7 must be used for luminance level measurement.
- The measurement position P_c must be at the center of the measurement area without line borders, have an RGB setting of 0, 0, 0, and be positioned at the center of the

screen. Alternatively, a measurement area with a size that is 80% of the active screen size may be used.

- The black level must be tested at maximum luminance, i.e., $\geq 200 \text{ cd/m}^2$.
- To achieve the maximum luminance, proceed as follows:
Use the TCO Certified default test image with an 18-step grey scale pattern presented on the screen. From the default setting, adjust the controls on the display to achieve as high luminance as possible with an acceptable image quality. The image quality is considered acceptable if at least 15 of the 18 grey scale steps are visible. The maximum luminance level must be $\geq 200 \text{ cd/m}^2$.
- If it is difficult to visually determine if 15 of the 18 grey scale steps are visible, then the display must conform with the *grayscale gamma curve* criteria in the max luminance setting.
- Change the color of the white measurement area in the test image to black (RGB: 0,0,0) and measure the luminance of the black area, check that it is $\leq 2 \text{ cd/m}^2$.

Equipment

Luminance meter or spectroradiometer.

Test method

The luminance at the center of the black measurement area must be measured with the luminance meter directed orthogonally to the measurement area as described in 9.2.5.

Test evaluation

The measured luminance is the required value. The luminance must be reported to one decimal place.

Overall uncertainty

$\leq \pm 10 \%$ in luminance.

See 9.1.10

5.14 Grayscale gamma curve

Background

A calibrated gamma curve makes it easier to distinguish between similar light levels. A well-tuned grayscale is the basis for accurate detail rendering of any imaging device. The grayscale rendering is measured by comparing a set number of steps in a grayscale in the test image. In order to give accurate rendering of the grayscale of the original image, each grayscale step, regardless of gray level, must have a luminance level close to what is specified by the common standard sRGB.

Definition

Grayscale gamma curve is the capability of the imaging device to maintain the original grayscale luminance or a grayscale pattern at all tested grayscale levels.

Applicability

Non monochromatic displays and all-in-one PCs with backlit or light emitting pixels.

References

5.6, 5.17, 5.20-5.25.

5.14.1 Mandate

The different grayscale luminance levels must be within the max and min levels specified in the table below, where 100% is the luminance level measured for white: RGB 255, 255, 255.

gray level	L_{sRGB}	L_{min}	L_{max}
	%	%	%
255	100	100,0	100,0
225	75	70	93
195	55	46	68
165	38	29	49
135	24	17	36
105	14	8	24
75	7	3	14
45	3	1	7

Submit The following ~~together with the application~~ is submitted to TCO

Development:

- A copy of the test report(s), and a copy of the verification report(s) from a verifier approved by TCO Development.
-

Draft 2

5.14.2 Clarification

Preparations for testing

- All necessary preparations described in 9.1 and 9.2 must be done.
- A TCO Certified default test image, as shown in figure 9.1.7, must be used for this measurement.
- The measurement area must have each of the following RGB settings: R=G=B=255, 225, 195, 165, 135, 105, 75 and 45.

Equipment

Luminance meter or spectroradiometer.

Test method

Measure the luminance at the center of the measurement area for each grayscale setting specified above. Change the grayscale of the area for each measurement.

Comments on the limits tolerance from the sRGB curve

A linear tolerance has been applied symmetrically around the sRGB gamma curve. However, as many displays on the market today have a somewhat S-shaped gamma curve, a “S-correction” has been added to the linear tolerance on the gamma level 225 and 195.

This correction has been determined based on statistics from measured displays. TCO Development may decide to remove this “S-correction” in the next generation of this criteria document.

Overall uncertainty

$\leq \pm 10\%$ in luminance.

See 9.1.10

6 Product lifetime extension

- In our current, linear way of producing and consuming products we take virgin natural resources and make products from them which we then discard once we're done using them – often after a relatively short time.
- Linearity leads to the loss of valuable and scarce natural resources, pollution and extensive energy use that contributes to the climate crisis.
- Moving toward sustainable solutions means creating a system that is more regenerative, where products and materials are kept in their intended use longer.

Linearity undermines ecosystems and the economy

Today, the common approach to the IT product life cycle is linear. Virgin materials are extracted to make new products which are used and then discarded, often after a relatively short time. In a majority of cases, materials are not recycled, and turn to waste. This linear “take, make, use, dispose” model is not sustainable and largely inefficient from a resource perspective. It depletes the earth's natural resources, and creates enormous amounts of hazardous e-waste.

Our approach: driving the development of products that can live longer

The best way to begin taking a more circular approach to the production and consumption of IT products, is extending their usable life. For the IT industry, this means designing products that are durable, built to last, upgradeable and repairable, making them more attractive for reuse or secondary markets. Once a product has reached the end of its usable life, the materials should be possible to recycle and use again in new products.

Criteria in chapter 6 focus on:

- Extending product life by requiring that products are durable, repairable and that spare parts and repair manuals are available.
- Making sure batteries in mobile products live longer, are replaceable and easily can be charged in a way that protects the battery from premature degradation.
- Enabling reuse of cables and reducing e-waste through requirements of standardized connectors.
- Incentivizing the IT industry to produce longer-lasting products by requiring that a product warranty must be in place on all markets where the product is sold.
- Preventing data leakage and promoting safe reselling of products through secure data removal solutions.

Draft 2

6.1 Product warranty

Background

~~By extending product lifetime, natural resources are used more efficiently and the pollution to air, water and soil is reduced.~~ A precondition for an extended product lifetime is that the product is of high quality. A product warranty provides the brand owner with an economic incentive to design a durable product that lasts longer and to encourage users to keep their products longer before replacing them.

Definitions

Brand owner: The company or organization owning or controlling the brand name.

Brand name: The name or sign, including but not limited to a trademark or company name, used to identify, amongst users and customers, the manufacturer or seller of a product.

~~Product warranty: Is an agreement where the brand owner offers to repair or replace broken products at no charge.~~

Product warranty: Covers defects existing at the time of delivery and those appearing after delivery that are due to material or manufacturing faults. It does not cover damages due to misuse or accidents. (However, functionality defects resulting from normal wear and tear, such as battery degradation, fan and keyboard wear-down, etc. must be covered.)

MSRP: Manufacturer's suggested retail price

Applicability

All product categories.

6.1.1 Mandate

~~The brand owner must:~~

- ~~• Provide a product warranty for at least one year,~~

~~AND~~

- ~~• Provide information about the minimum product warranty period for the product~~

~~covering~~In all markets where the product is sold-, the brand owner must:

- Offer a 5-year minimum available warranty, where at least 1 year must be included free of charge.
- Each year of warranty, which is not included free of charge, must be offered for a maximum of 15% of the MSRP of the product and must be available for purchase together with the product.

Submit the following to an approved verifier:

- [A link to a public statement in English covering the warranty of the certified product.](#)
- A completed and signed brand owner product form (chapter 11.4).

Submit The following ~~together with the application~~ **is submitted** to TCO

Development:

- A copy of the verification report(s) from a verifier approved by TCO Development.

The following is submitted to TCO Development and may be published:

- [Minimum included product warranty in years](#)
 - [Minimum purchasable extended warranty in years](#)
 - [Minimum total available warranty in years \(free + extended\)](#)
 - [The maximum cost \(in % of product cost\) per year for the extended warranty](#)
 - [A link to a public commitment on warranty covering the certified product](#)
-

6.1.2 Clarification

Clarification of sustainability performance indicator(s)

One or more “sustainability performance indicators” (chapter 1.3) are collected for this criterion. There is no mandatory level for these indicators but they ~~must be~~ [The brand owner](#) must be verified and

~~reported according~~ [provide a link to a public statement in English covering the description below.](#)

Warranty period (Class A-G)

The minimum number of years the ~~whole~~certified product ~~is covered by warranty~~

- ~~Class A~~ Product warranty for at least 7 years, covering all markets, where the brand owner commits to the minimum warranties on any market where the product is sold
- ~~Class B~~ Product, as well as information on how to purchase an extended warranty, for at least 6 years, covering all markets where the product is sold

~~Class C~~ Product warranty for at least 5 years, covering all markets ~~where~~example, directly from the ~~product is sold~~brand owner's webshops or through a retailer.

- ~~Class D~~ Product warranty for at least 4 years, covering all markets where the product is sold
- ~~Class E~~ Product warranty for at least 3 years, covering all markets where the product is sold
- ~~Class F~~ Product warranty for at least 2 years, covering all markets where the product is sold
- ~~Class G~~ Product warranty for at least 1 years, covering all markets where the product is sold

Verification: Documentation proving the ~~product warranty period, covering all markets where the product is sold.~~ If product components have different warranty periods, or if different warranty periods are offered in different regions, the worst-case scenario (least number of years) must be ~~reported~~used in the statement.

The following SPI(s) is not required for compliance with TCO Certified. If no information is provided the product will receive the lowest classification by default.

Extended warranty availability (Class A-G)

The maximumLink to a public commitment on warranty covering the certified product

The link must be functioning during the validity of the certificate. If the URL is changed, then it must first be approved by TCO certified and the new URL added to the certificate.

Minimum included product warranty

This is the minimum number of years ~~the product warranty can be extended to covering the whole~~(at least 1 year) of product:-

- ~~Class A~~ Extended warranty for the product ~~is available for 7 years or more on all markets where the product is sold~~

- ~~Class B~~ Extended warranty for the product is available for at least 6 years on all markets where the product is sold
- ~~Class C~~ Extended warranty for the product is available for at least 5 years on all markets where the product is sold
- ~~Class D~~ Extended warranty for the product is available for at least 4 years on all markets where the product is sold

~~Class E~~ Extended warranty for the product is available for at least 3 years that is included for free on all markets where the product is sold.

~~Class F~~

Minimum purchasable extended warranty

This is the minimum optional extension of the product warranty, offered for purchase with the product on all markets.

Minimum total available warranty

This is the worst-case combination of "included product warranty" and "purchasable extended warranty" on any market where the product is sold.

Maximum warranty cost per year (in % of product cost)

- ~~This is the maximum annual cost for the purchasable extended warranty for must not exceed 15% of the product is available up to 2 years on all markets where MSRP cost of the product is sold~~
- ~~Class G~~ No information provided

Verification: Documentation proving the maximum availability of an extended warranty for the product for all markets where the product is sold. If product components have different warranty periods, the worst case scenario (least number of years) must be reported. Extended warranty is defined as the warranty time that exceeds the base warranty period.

Public repair policy (A-C)

- ~~Class A~~
 - ~~Product repair is favored before product replacement.~~
 - ~~A repair policy is publicly available.~~
- ~~Class B~~
 - ~~No policy on product repair vs. replacement~~
- ~~Class C~~
 - ~~No information provided~~

Verification: A link to a Public policy proving the type of repair policy.

Draft 2

6.2 Replaceable components

Background

Extending the lifetime of IT products is the most effective way to reduce their environmental impact. Components that often break or become outdated may limit the total lifespan of the product and must be replaceable. ~~By making these critical replaceable components available and~~By providing the user with clear instructions on how to ~~exchange them,replace these critical components~~, IT-products can live longer.

Definitions

CPU: Central processing unit.

GPU: Graphics processing unit.

RAM: Random access memory.

Storage: Any computing hardware that is used for storing, porting, and extracting data files and objects, including temporary and permanent storage of information (SSD, HDD, RAM).

Display assembly: Main display panel.

All batteries: Defined as all batteries with one or more cells that are installed in the product.

System board: Also referred to as the motherboard.

Keyboard: Built-in keyboard.

External/Internal PSU: The power supply unit used to convert AC to low voltage DC power for the internal components of the product.

Critical, replaceable components: Components that are crucial for the functionality and have a high risk of failing during normal use. Components that are defined as critical, replaceable components (per product category) are listed in the clarifications section of this criterion.

Applicability

All product categories.

References

6.1, 6.2.

6.2.1 Mandate

- The brand owner must provide a service manual describing how to replace at least all critical replaceable components. The service manual must be available for anyone to read, free of charge ~~in case the critical replaceable components are available for anyone to purchase or to the service network.~~
- ~~1. The brand owner must guarantee that, during the validity of the certificate, all critical replaceable components for the product type; that are listed in the clarifications of this criterion;~~
 - ~~○ are available for anyone to purchase~~
 - ~~or~~
 - ~~○ may be replaced by a service network for repair and maintenance of the certified product on all markets where it is sold.~~

Submit the following to an approved verifier:

- A completed and signed brand owner [product](#) form (chapter 11.4)
- A link to the service manual on the brand owner website or a pdf of the material that will be published there during the validity of the certificate

~~Submit~~ The following ~~together with the application is submitted~~ to TCO

Development:

- A copy of the verification report(s) from a verifier approved by TCO Development, [including the link and instructions on how to locate the service manual.](#)

6.2.2 Clarification

Replaceable parts management

- The brand owner must provide a service manual including step-by-step instructions and component descriptions for the disassembly and assembly.
 - External PSU, charger, and AC Adapters are exempted from the disassembly instructions.
 - If instructions on how to replace all critical replaceable components (listed below) are included in the user manual, no additional service manual is needed to comply with the mandate 6.2.1.
- [Board diagrams must be available for professional repairers free of charge.](#)

- A critical, replaceable component must be possible to replace with an equivalent component. However, the replacement component does not have to be identical to the original component.
- Instructions on how to replace the critical components must be available online during the validity of the certificate.
- If a critical component is soldered, step-by-step instructions on how to replace soldered components does are not need to needed, however it must be listed stated that the component is soldered in the service- or user manual (mandate 6.2.1).
- For data center products (Servers, Storage products, Network equipment), if one or more critical replaceable component(s) are part of a controller canister or system board, the controller canister or system board must be treated as the critical component.
- Headband cushions which are molded do not need to be replaceable. Headband cushions designed to be snapped/mounted (for eg, with adhesive) shall be replaceable.

Critical replaceable components:

The critical replaceable components listed below must only be made available if they are included in the certified product.

Displays Connectivity cables Power cables External PSU System board/motherboard Display panel assembly	Tablets Battery Display Panel/display assembly External/internal PSU
All-in-one PCs CPU External/internal PSU Storage (SSD, HDD, ODD) System memory (RAM) System board/motherboard	Smartphones Battery Display Panel/display assembly Charger
Notebooks Battery Display Panel/display assembly Storage (SSD, HDD) System memory (RAM) External/internal PSU Keyboard System board/motherboard	Headsets Battery External/internal PSU Earloop Neckband Ear tips Ear cushions Microphone shield Headband
Desktops CPU GPU (PCIe) External/internal PSU Storage (SSD, HDD, ODD) System memory (RAM) System board/motherboard	Projectors The light source (except lasers) Filters External PSU

<p>Servers</p> <p>System boards(s) Storage (i.e. SSD, HDD) CPU RAM Network device PSU Fan module(s) Connectivity cables Rack rails Cable management arms</p>	<p>Storage products</p> <p>System board(s) Storage (i.e. SSD, HDD) Storage controller (i.e. RAID controllers) PSU Fan module(s) Batteries Connectivity cables Rack rails Cable management arms</p>
<p>Network equipment</p> <p>System board(s) Storage (i.e. SSD, HDD) PSU Fan module(s) Expansion module(s) I/O module(s) Connectivity cables Rack rails Cable management arms</p>	
<p><i>Component table</i></p>	

Component table

Clarification of sustainability performance indicator (SPI)(s)

One or more “sustainability performance indicators” (chapter 1.3) are collected for this criterion. There is no mandatory level for these indicators but they must be verified and reported according to the description below.

Replaceability and repairability of the product

For each critical component in the component table above, the following evaluation must be completed to calculate the repairability and reusability of the product. The evaluation is based on the standard EN 45554:2020—General methods for the assessment of the ability to repair, reuse and upgrade energy related products:

1. Fasteners and connectors (Class A-D)
2. Necessary tools for repair/upgrade, (Class A-D)
3. Availability of spare parts
 - a. Availability by target group (Class A-E)
 - b. Duration of availability (Class A-D)
4. Comprehensiveness of available information (Class A-C)

1. Fasteners and connectors (Class A-D)

The reusability of fasteners and connectors is interlinked with the repairability and reusability of products and components. Knowledge of type of fasteners can assist with the assessment of tools and skills necessary for repair reuse or upgrade:

Evaluation procedure

The assessment of the fasteners and connectors must be done from the start until the component is removed. This means that if any other part needs to be removed before it is possible to remove the critical component, then those steps must also be taken into consideration for the final score.

● Class A: Reusable

- An original fastening system that can be completely reused, or any elements of the fastening system that cannot be reused are supplied with the new part for the repair, reuse or upgrade process.

● Class B: Removable

- An original fastening system that is not reusable, but can be removed without causing damage or leaving residue which hinders reassembly (in case of repair or upgrade) or reuse of the removed part (in case of reuse) for the repair, reuse or upgrade process.

● Class C: Neither removable nor reusable

○ An original fastening system that is not removable and not reusable, as defined above, for the repair, reuse or upgrade process.

● **Class D: No evaluation performed**

Draft 2

Example for a battery in a notebook:

Example 1

Step 1—Remove eight screws to open the chassis—Class A

Step 2—Remove four screws and loosen the connector to the motherboard—Class A

Step 3—The battery can now be replaced without additional steps—Class A

Total score for battery component: Class A

Example 2

Step 1—Remove eight screws to open the chassis—Class A

Step 2—Remove four screws and loosen the connector to the motherboard—Class A

Step 3—The battery is glued with non-reusable adhesive—Class B

Total score for battery component: Class B

Example for a power board in a display:

Example 1

Step 1—Remove eight screws to open the chassis—Class A

Step 2—Remove four screws and loosen the connector to the motherboard—Class A

Step 3—Remove four screws and loosen the connector to the power board—Class A

Total score for power board component: Class A

Example 2

Step 1—Remove eight screws to open the chassis—Class A

Step 2—Remove four screws and loosen the connector to the motherboard—Class A

Step 3—The connector to the power board is *taped* and fastened with screws—Class B

Total score for power board component: Class B

If a component is soldered to another component, it automatically receives Class C.

2. Necessary tools for repair/upgrade (Class A-E)

The availability of tools necessary for repair, service or upgrade, are interlinked with the product lifetime. Without easy access to tools needed for repair, upgrade or service the likelihood of these decrease. Therefore, it is important to make use of tools that are readily available instead of using proprietary tools:

● Class A: Basic tools, no tools, provided tools

- Replacing critical components can be carried out without the use of any tools; or with a tool or set of tools that is supplied with the product or spare part, or with basic tools as listed in Table A.

- All tools required must be listed in the service manual.

Table A Basic tools

- **Class B: Other commercially available tools:**

- Replacing critical components can be carried out with non-proprietary tools that are not Class A.
- All tools required must be listed in the service manual.

Verification: The brand owner must include a link to a shop where the tools can be bought in the service manual.

- **Class C: Can be carried out with proprietary tools:**

- The tools required to replace critical components can be carried out with use of proprietary tools. These are tools that are not available for purchase by the general public or for which any applicable patents are not available to license under fair, reasonable, and non-discriminatory terms.

Verification: The brand owner must state in the service manual that the tools needed are proprietary.

- **Class D: Not enough information, or not feasible with any existing tools:**

- The tools listed in the service manual are not Class A, and no extra information is made available on where usable tools can be purchased, or if they are proprietary.

or

- The tools required to replace the critical components are not listed in the service manual.

- **Class E: No evaluation performed**

3. Availability of spare parts

The availability of spare parts is a prerequisite for a successful repair. Spare parts availability refers to both the availability to various target groups and the availability over a specific period of time. These two perspectives are assessed in sequence.

3.a. Availability by target group (Class A-E)

- ~~Class A: Publicly available~~
- ~~Class B: Available to independent repair service providers~~
- ~~Class C: Available to brand owner authorized repair service providers~~
- ~~Class D: Available to the brand owner only~~
- ~~Class E: No spare parts available or no information on availability~~

*Verification: The brand owner must pledge the availability of spare parts in the service manual.
Read*

3.b. Duration of availability (Class A-D)

- ~~Class A: Long-term availability (6 or more years)~~
- ~~Class B: Mid-term availability (4 or more years)~~
- ~~Class C: Short-term availability (2 or more years)~~
- ~~Class D: No information on duration of availability~~

Verification: The brand owner must pledge the minimum duration of availability for spare parts in the service manual.

4. Comprehensiveness of available information (Class A-C)

The comprehensiveness of service information facilitates the possibility for repairs, maintenance and upgrades, which enables the extension of product lifetime.

● **Class A: Comprehensive information available**

A repair, reuse or upgrade process, for which the following information is available for anyone to read, free of charge:

- Step-by-step disassembly instructions with identification of tools needed.
- Information on where to attain all tools needed for repair/upgrade.
- An overview of repair or upgrade services offered by the manufacturer.
- Troubleshooting charts.
- Circuit board schematics (only main board).
- Functional specification of parts (e.g. resistance value of resistors).
- Recommended torque for fasteners.
- Diagnostic and error resetting codes.

or

- Appropriate formats for reporting comprehensive information can include IEEE1874 (IEEE Standard for Documentation Schema for Repair and Assembly of Electronic Devices).

● **Class B: Basic information available**

A repair, reuse or upgrade process, for which the following information is available for anyone to read, free of charge:

- Step-by-step disassembly instructions with identification of tools needed.
- Information on where to attain all tools needed for repair/upgrade.
- An overview of repair or upgrade services offered by the manufacturer.
- Troubleshooting charts.

● **Class C: Limited information available**

A repair, reuse or upgrade process, for which the following information is available for anyone to read, free of charge:

- Step-by-step disassembly instructions with identification of tools needed.

Verification: Unless the brand owner provides documentation showing compliance with Class A or B, the product will be categorized as Class C.

6.3 Standardized connectors

Background

By using one standardized interface (USB Type-C) for charging and data transfer, fewer cables need to be manufactured, and the [reuse](#) of chargers and data cables can increase. USB Type-C is also designed to be more robust and future-proof than the existing USB Type-A and Type-B. Therefore, using USB Type-C helps prevent problems with failing ports.

~~The connector can also enable features such as eGPU for notebooks that make it possible to upgrade the GPU performance with standalone graphics cards. This means that a user will be able to keep the same product for a longer time.~~

Definitions

USB Type-C: A 24-pin USB connector system with a horizontally symmetrical "reversible" connector: [based on the "Universal Serial Bus Type-C Cable and Connector Specification"](#).

Applicability

Notebooks, desktops, AIOs, [smartphones, tablets](#)

6.3.1 Mandate

The device must [carry be equipped with](#) at least one USB Type-C [connector that is backwardreceptacle](#) compatible with USB [2.03.1 Gen 1 or faster and that remains accessible and operational at all times](#).

Submit the following to an approved verifier:

- A completed and signed product form (chapter 11.3)
- [SubmitA product manual including an exploded diagram of the device illustrating the types of connectors used.](#)

The following ~~together with the application~~ is submitted to TCO Development:

- A copy of the verification report(s) from a verifier approved by TCO Development.
-

6.3.2 Clarification

Products with no connectors are exempted from this criterion.

Draft 2

6.4 Secure data removal

Background

By reusing IT products, their usable life can be extended which is an effective way of reducing their environmental impact. However, fear of confidential data leakage often prevents companies and individuals from making their products available on the second-hand market. By providing software that wipes the storage of the device, the owner can more safely recirculate their product.

Definitions

Brand owner: The company or organization owning or controlling the brand name.

Brand name: The name or sign, including but not limited to a trademark or company name, used to identify, amongst users and customers, the manufacturer or seller of a product.

Media sanitization: refers to a process that renders access to target data on the media infeasible for a given level of effort.

[NIST 800-88 Revision 1: Erasing a hard drive using the NIST 800-88 Revision 1 data sanitization method will prevent all software-based file recovery methods and hardware-based recovery methods from recovering data from the drive.](#)

Applicability

Notebooks, network equipment, desktops, all-in-one PCs, servers, data storage products, smartphones and tablets.

Reference

6.7.

6.4.1 Mandate

The brand owner must provide a media sanitization solution, either by:

1. Pre-installing it on/in the product before it is shipped.
2. Providing the software for download on their webpage, free of charge.
3. Providing a direct link on their own webpage to an external webpage where the software is available for download, free of charge.
4. Providing a remote secure data removal service upon request, free of charge.
5. Providing an on-site secure data removal service upon request, free of charge.

The selected media sanitization solution above must conform with the [guidelines of NIST 800-88 Revision 1, for the level of "Clear" in accordance with the products storage](#)

[technology:method of “Clear” in IEEE P2883](#). Users must be able to use it at least once, free of charge.

OR

6. Pre-installed data encryption technologies that allow for erasure or removal of the encryption keys.

[Submit the following to an approved verifier:](#)

[Instructions on how to use this functionality, the techniques used and the secure data deletion standard\(s\) it supports must be provided in the user manual and/or by a web link to the manufacturer’s webpage.](#)

[The following is submitted to TCO Development:](#)

- A completed and signed product form (chapter 11.3).

Submit the following together with the application to TCO Development:

- A copy of the verification report from a verifier approved by TCO Development.

6.4.2 Clarification

[We accept “enhanced secure erase” as an option for ATA SSDs to comply with the level of “Clear” in NIST 800-88 Revision 1.](#)

[Pre-installed data encryption technologies must have a security stronger or equal to: AES encryption algorithm in cipher block chaining \(CBC\) or XTS mode with a 128-bit or 256-bit key.](#)

6.5 Security and functionality software updates

Background

Devices may become obsolete or vulnerable due to infrequent software updates, putting user data at risk and curtailing device longevity. Therefore TCO Certified intends to address the following challenges:

- Consumer Protection: Consistent security updates minimize risks from cyber threats and unauthorized data access.
- Device Longevity: By ensuring functionality updates, devices remain relevant longer, delivering better value to users and reducing electronic waste.
- Holding Manufacturers Accountable: This enforces a set support duration, nudging manufacturers towards more sustainable designs and post-sale maintenance.

Definitions

- Security update: An operating system update, including security patches, if relevant for a given device, whose main purpose is to provide enhanced security for the device.
- Corrective update: An operating system update, including corrective patches, whose purpose is to provide corrections to bugs, or malfunctions in the operating system.
- Functionality update: An operating system update whose main purpose is to implement new functionalities.
- "The date of end of placement on the market" is defined as "the last manufacturing date" in this criterion.

Applicability

All product categories.

6.5.1 Mandate

- The brand owner must publicly guarantee the availability of free-of-charge security updates, corrective updates and functionality updates to the operating system for at least 5 years after the end of placement on the market.

Submit the following to an approved verifier:

- A completed and signed brand owner product form (chapter 11.4).
- A link to a public statement where the brand guarantees the availability of these updates.
- The last year, the brand owner publicly committed to delivering such updates.

The following is submitted to TCO Development:

- A copy of the verification report(s) from a verifier approved by TCO Development.

The following is submitted to TCO Development and may be published:

- A link to a public statement where the brand guarantees the availability of these updates.
 - The last year, the brand owner publicly committed to delivering such updates.
-

6.5.2 Clarification of sustainability performance indicator(s)

One or more “sustainability performance indicators” (chapter 1.3) are collected for this criterion. There is no mandatory level for these indicators but they must be verified and reported according to the description below.

Media sanitization solution (Class A-B)

- **Class A** Media sanitization solution: 1 or 6
- **Class B** Media sanitization solution: 2, 3, 4 or 5

Compliance with EN 45554:2020 – A.4.11 Data management (Class A-B)

This criterion can be used as verification of conformity with EN 45554:2020 A.4.11 Data management:

- **Class A** No data stored or built in : media sanitization solution: 1
- **Class B** On request: media sanitization solution: 2, 3, 4, 5 or 6

The manufacturing date is possible to verify on a product level in a spot check program. The last manufacturing date is considered representative of “the date of end of placement on the market.” Therefore, “the date of end of placement on the market” is defined as “the last manufacturing date” in this criterion.

Verification guideline

The brand owner must provide a link to a public statement where they guarantee the availability of security updates, corrective updates and functionality updates to the operating system for at least 5 years after the end of production of the certified product as well as information on how these updates will be provided. The link must be functioning during the validity of the certificate.

The software updates must cover the operating system delivered with the product or a newer version of the same operating system that must then be supported by the product without any additional cost for the user.

Draft 2

7 Reduction of hazardous substances

- Hazardous substances used in IT products ~~are a risk to~~ human health and the natural environment.
- Legislation is lagging and focuses on banning substances, but the substitutions can be just as hazardous, or even worse.
- TCO Certified drives transparency and knowledge-sharing, developing pathways to safer alternatives.

Hazardous substances – a risk to human health and the environment

No one knows how many chemicals are in use today. What we do know is that very few of these substances have been studied for their impact on humans and the environment. ~~Two~~ Examples of potentially hazardous substances are plasticizers ~~and~~, flame retardants ~~and~~ [stabilizers](#), often used in components, cables and other plastic parts. These substances risk leaking out in the natural environment, both in connection with manufacturing, and when products and their packaging are incinerated, placed in landfill or recycled in an improper way.

Keeping hazardous substances out of products is [also](#) important ~~also~~ from a circular perspective. Contaminated materials cannot be responsibly recycled and reused in new products, and risk therefore being incinerated or discarded, adding to the enormous e-waste problem.

Our approach: guiding the IT industry to safer alternatives

For a long time, TCO Certified has restricted the use of harmful substances with criteria that go beyond RoHS. However, simply banning substances isn't enough. A banned substance may be replaced with another that is equally harmful, or potentially even worse. Therefore, we need better information about substances before they are being used. With TCO Certified, a chemical is considered a high risk until it is proven to be otherwise. GreenScreen® for Safer Chemicals is used to identify a pathway to safer alternatives.

Criteria in chapter 7 focus on:

- Reducing or eliminating the use of hazardous substances in IT products and their packaging, beyond RoHS.
- Requiring that all flame retardants ~~and~~, plasticizers [and stabilizers](#) are assessed by an independent toxicologist and benchmarked as a safer alternative before being used in

certified products. The same principle applies also to process chemicals, covered in chapter 2.

- Increasing transparency and making safer alternatives the mainstream choice by collecting all approved substances on the public and dynamic TCO Certified Accepted Substance List.

Draft 2

7.1 Heavy metals

Background

Electronic devices contain hazardous substances like heavy metals and brominated flame retardants. The effects of cadmium, mercury, lead and hexavalent chromium are well documented as substances hazardous both to human health and the environment. They may cause problems, both in the manufacturing phase where workers or the environment can be exposed, and at the material recovery, where uncontrolled recycling can cause the release of toxins such as dioxins and furans.

This criterion is harmonized with EU RoHS Directive (2011/65/EU), except that in TCO Certified, mercury is not allowed in lamps. As TCO Certified is a global certification, this also affects products sold outside the EU.

Applicability

~~Displays, notebooks, tablets, smartphones, desktops, all-in-one PC's, headsets, servers, network equipment, data storage products.~~
[All product categories.](#)

References

7.1, 7.2.

7.1.1 Mandate

The product must not contain cadmium, mercury, lead and hexavalent chromium

Exemptions are according to EU Directive 2011/65/EU (RoHS) and the documents supporting the directive, except that mercury in lamps is not permitted.

The maximum concentration values tolerated by weight in homogeneous materials are 0.01% for cadmium, 0.1% for mercury, 0.1% for lead and 0.1% for hexavalent chromium according to EU RoHS Directive (2011/65/EU annex II) and the documents supporting the directive.

The limit value for batteries is 0.0005 % for mercury, 0.002 % for cadmium and 0.004 % lead per listed part, according to [EU Directive 2006/66/EC Regulation \(EU\) 2023/1542](#).

Submit the following to an approved verifier:

- A completed and signed product form (chapter 11.3).

Submit The following ~~together with the application~~ is submitted to TCO

Development:

- A copy of a verification report from a verifier approved by TCO Development.
-

Draft 2

7.2 Halogens

Background

Halogenated substances are often persistent and can bio-accumulate in living organisms. They are problematic from both a human health and environmental perspective throughout the product life cycle and should be phased out. Workers may be exposed during manufacturing. Substances risk leaking out into the natural environment at end of life. PVC is by far the most common halogen-containing plastic.

Definitions

An electronic component is considered an individual part or combination of parts that, when together, perform a design function(s) and are typically directly attached to a printed circuit board. Internal and external power supplies are not included in the definition.

Product housing is considered the external enclosure or casing that protects the internal parts of a product. This includes a product stand and external power supplies.

Product housing protects internal components and safeguards the user against injury from these electrical components. Product safety standards define these safeguards as different types of protective enclosures. These enclosures are added to safeguard against electrical shock, high temperatures, fire and mechanical (moving parts such as the fan), and radiation (such as any internal laser), whilst also protecting internal parts.

Printed circuit board (PCB) or printed wiring board (PWB) laminate is a printed board that provides point-to-point connections.

Power board or power PCB regulates the power leading to the device, converting alternating current to direct current

Polybrominated biphenyls (PBB) and polybrominated diphenyl ethers (PBDE) are restricted in the EU RoHS Directive (2011/65/EU) due to the hazardous properties of these substances.

Hexabromocyclododecane (HBCDD) has been identified as a substance of very high concern in accordance with EU REACH criteria due to PBT (persistent, bio-accumulative, toxic) properties.

External cables delivered with the product: Cables that provide power to the product and cables that connect the product to an external peripheral (USB-USB, HDMI-HDMI, HDMI-DP, VGA-VGA, etc).

Applicability

All product categories.

References

7.2, 7.3.

Draft 2

7.2.1 Mandate

1. Product housing parts above 0.5 grams ~~and the power, printed circuit board (PCB laminate of the internal/external power supply unit) laminates and external cables delivered with the certified product~~ must not contain intentionally added (additive or reactive) ~~flame retardants or plasticizers with~~ halogenated ~~flame retardant, plasticizer or vinyl polymer stabilizer~~ substances.

Exempted are all other parts, such as electronic components, ~~other and~~ PCB ~~laminates laminates and all kinds of cable insulation.~~

~~sealed inside electronic components.~~

2. The product must not contain PBB, PBDE and HBCDD. No parts of the product are exempted.
3. The largest PCB by area in the power supply unit (internal/external) must be tested for bromine and chlorine; (see clarification below).

Maximum concentration values tolerated for a ~~restricted~~non-accepted substance (including decaBDE) is 0.1% by weight of the material in homogeneous materials. Fluoroorganic additives, used to modify the dripping behavior of plastics in fire conditions or to improve the processing behavior, are exempted provided that they do not exceed 0.5% by weight of the material in homogeneous materials.

Submit the following to an approved verifier:

- A completed and signed product form (chapter 11.3).
- A copy of the test report(s) from any laboratory accredited according to ISO 17025

~~Submit~~ The following ~~together with the application is submitted~~ to TCO

Development:

- A copy of the test report(s) from any laboratory accredited according to ISO 17025 and a copy of the verification report(s) from a verifier approved by TCO Development.

7.2.2 Clarification

[Point 1 of the mandate 1](#). Applies to product housing parts above 0.5 grams. This includes the product stand and the housing of the external power supply. The internal or external power supply socket or inlet is ~~not~~ included in the definition of product housing.

~~The power board laminate of the internal or external power supply is the only PCB that is mandated due to the high risk for their being added flame retardants to this part. All other PCBs inside the product are exempted.~~

[Point 2 of the PCB laminates completely sealed within an electronic component are exempted. External cables delivered with the product are considered cables provided to supply power to the product and connect the product to an external peripheral \(USB-USB, HDMI-HDMI, HDMI-DP, VGA-VGA, etc\).](#)

See mandate [for non-halogenated substances for the requirements on safer substitution](#).

[2](#). Applies to the whole ~~of the~~ product, including components, parts and raw materials in all assemblies and sub-assemblies, such as batteries, paint, surface treatment, plastics, electronic components and printed wiring boards.

[Point 3 of the mandate 3](#). Applies to the testing for bromine and chlorine where the following is required:

The largest PCB by area in the power supply unit must be tested for bromine and chlorine. The PCB must be tested in its final state with PCB laminates included but does not need to be tested with electrical components attached. Testing must be conducted through either IEC IEC 62321-3-1:2013, 62321-3-2:2020 or EN14582 by an ISO 17025 accredited laboratory. If the same PCB is used in multiple products, a test report may be used for multiple products if traceability between the tested sample and the product is verified.

- If indications of bromine or chlorine >0.1% are discovered, the applicant must proceed with additional testing ~~in order~~ to prove compliance with this criterion.
- If the concentration of [a](#) detected substance is <0.1%, then no additional testing is needed.

7.3 Non-halogenated substances

Background

Hazardous non-halogenated substances are problematic in the manufacturing and material recovery phases where workers and the environment can be exposed, leading to ~~both~~ human health and environmental risks. ~~The purpose of~~ This criterion ~~is~~ ~~aims~~ to increase the knowledge of which non-halogenated substances are used in certified products, how hazardous they are to human health and the environment, and to drive a shift toward less hazardous alternatives.

This mandate uses the [chemical](#) hazard assessment and decision logic framework GreenScreen® for Safer Chemicals, developed by the non-profit organization Clean Production Action (CPA), ~~and the ChemFORWARD hazard banding system based on the Cradle to Cradle Material Health Assessment Methodology.~~

~~GreenScreen criteria are in line~~ [Both methods align](#) with international standards and regulations that assess ~~the chemicals'~~ human health and environmental risks ~~of chemicals~~.

These include the Regulation on the classification, labelling and packaging of substances and mixtures (CLP), [the](#) Globally Harmonized System of Classification and Labelling of Chemicals (GHS), OECD testing protocols, European REACH Regulation that includes RoHs, POPs, SVHCs and the U.S. EPA's Design for Environment (DfE) Alternatives Assessment.

Definitions

[Licensed](#) GreenScreen Profilers: [and ChemFORWARD qualified assessors: Independent toxicology firms licensed/qualified](#) by CPA/[ChemFORWARD](#) to provide [GreenScreen](#) assessment services for a fee to clients.

TCO Certified Accepted Substance List: Public list of independently assessed safer available alternatives considering toxicity and functionality. ~~Go to:~~

~~Clean Production Action (CPA). Developers of GreenScreen® for Safer Chemicals:~~

[An](#) electronic component is considered an individual part or combination of parts that, when together, perform a design function(s) and are typically directly attached to a printed circuit board. Internal and external power supplies are not included in the definition.

Product housing ~~is considered the external enclosure or casing that~~ protects ~~the~~ internal [components and safeguards the user against injury from these electrical components.](#)

[Product safety standards define these safeguards as different types of protective enclosures. These enclosures are added to safeguard against electrical shock, high temperatures, fire and mechanical \(moving parts of such as the fan\), and radiation \(such as any internal laser\), whilst also protecting internal parts.](#)

External cables delivered with the product. This includes: Cables that provide power to the product stand and cables that connect the product to an external peripheral (USB-USB, HDMI-HDMI, HDMI-DP, VGA-VGA, etc).

Applicability

All product categories.

References

7.4, 7.5, 7.6.

Draft 2

7.3.1 Mandate

Product housing parts above 0.5 grams ~~and the power, printed circuit board (PCB laminate of the internal/)~~ laminates and external ~~power supply unit~~ cables delivered with the certified ~~product~~ must only contain intentionally added (additive or reactive) non-halogenated flame retardants ~~that have been assigned a GreenScreen benchmark score of 2, 3 or 4 by a licensed GreenScreen Profiler and~~ and vinyl polymer stabilizers that appear on ~~the public-~~TCO Certified Accepted Substance List. ~~(A benchmark U may only be accepted when the “worst case scenario” for data gaps is considered to be a benchmark 2 or above.)~~

All substances of a [flame retardant and stabilizer](#) mixture must be accounted for. Non-accepted substances must not exceed concentration levels of 0.1% by weight of the flame retardant [and stabilizer](#).

Exempted are all other parts, such as electronic components and [all kinds of cable insulation](#) PCB laminates sealed inside electronic components.

Submit the following to an approved verifier:

- A completed and signed product form (chapter 11.3).

~~Submit~~ The following ~~together with the application~~ is submitted to TCO

Development:

- A copy of a verification report from a verifier approved by TCO Development.
- A document copy or access to a database copy of the certified assessment report conducted and issued by a licensed GreenScreen Profiler.

7.3.2 Clarification

~~The mandate~~ Applies to product housing parts above 0.5 grams. This includes the product stand and the housing of the external power supply. The internal or external power supply socket or inlet is ~~not~~ included in the definition of product housing.

~~The power board laminate of the internal or external power supply is the only PCB that is mandated due to the high risk for their being added flame retardants to this part. All other PCBs inside the product are exempted.~~

~~Only PCB laminates completely sealed within an electronic component are exempted.~~

~~External cables delivered with the product are considered cables provided to supply power to the product, and to connect the product to an external peripheral (USB-USB, HDMI-HDMI, HDMI-DP, VGA-VGA, etc).~~

TCO Certified Accepted Substance List

Non-halogenated flame retardants can be used in certified products once they receive an accepted [GreenScreen](#) benchmark [or ChemFORWARD hazard band](#), and appear on the public TCO Certified Accepted Substance List. [GreenScreen benchmarks 2, 3 or 4 assigned by a licensed GreenScreen profiler or hazard bands A, B or C assigned by a qualified ChemFORWARD assessor are accepted to appear on TCO Certified Accepted Substance List. A GreenScreen benchmark U may only be accepted when the “worst case scenario” for data gaps is considered a benchmark 2 or above.](#) The list is dynamic, which allows new substances that have undergone a valid assessment to be added [at any time](#). Accepted substances may be reassessed in light of new scientific findings.

~~If an accepted substance is reassessed and given a benchmark score lower than 2, TCO Development reserves the right to remove the substance from TCO Certified Accepted Substance List. Before a substance is removed from the list a sunset date (at least one year) is set and shown on the list. This is to give chemical and product manufacturers time to submit additional information, must have access to improve the benchmark score or to transfer to an alternative on the list. Product models that use a removed chemical but were certified copy of the GreenScreen and ChemFORWARD assessment reports before the sunset date are permitted substance can be added to TCO Certified Accepted Substance List.~~

Conformity procedure

- ~~If all substances relevant to this mandate are confirmed by suppliers to keep their TCO Certified certificate. Models certified after the sunset date may only contain flame retardants or plasticisers that are listed be on TCO Certified Accepted Substance List, complete the product form 11.3 and submit it to an approved verifier. When the verifier considers all documentation compliant, they will issue an environmental verification to the applicant.~~
- ~~If any substance relevant to this mandate does not yet appear on TCO Certified Accepted Substance List, then it must be added before approval can be given by a verifier. An extended time period to comply can be applied here (see “Applying for an extended period...” below).~~
- ~~Any spot checks by~~ TCO Development will require manufacturers to disclose substance details ~~being~~ used in randomly chosen products. To verify that the obligations according to this mandate are fulfilled CASNR disclosure and laboratory assessments of selected parts will be conducted to assess the completeness, quality and validity of a benchmark score.

TCO Development Get a substance assessed and **Clean Production Action (CPA)** must have access to a copy of the **GreenScreen** assessment report before the substance can be added to **TCO Certified Accepted Substance List**, ~~available at~~:

Conformity procedure

- ~~The applicant must contact relevant suppliers and ask them to confirm that the flame retardants and plasticizers they use only include substances listed on TCO Certified Accepted Substance List.~~
- ~~If all flame retardants and plasticizers only include substances on TCO Certified Accepted Substance List, complete the product form 11.3 and submit it to an approved verifier. When the verifier considers all documentation to be compliant, they will issue an environmental verification to the applicant.~~
- ~~If any flame retardant or plasticizer is used that contains a substance that is above the threshold level but doesn't appear on TCO Certified Accepted Substance List, then it must be added before approval can be given by a verifier. An extended time period to comply can be applied for here (see "Applying for an extended period..." below).~~

Adding a substance to the TCO Certified Accepted Substance List:

- First, determine if the substance is restricted or already has a valid assessment available.
 - a. Contact TCO Development directly to see if the substance is restricted.
 - a.b. Visit TCO Certified Potential Candidate List to see if we have any additional information on the substance. Reasons for the substance's absence can be that the substance has received benchmark 1, that no a previous assessment has been conducted or that it has a benchmark score U (unspecified), due to a high number of data gaps completed and the profiler/assessor that completed it.
 - c. If TCO Development requires the substance to be benchmarked, we recommend that you contact your suppliers and inform them that the substance will need an Visit the GreenScreen Assessment Registry or contact ChemFORWARD to see if a valid assessment by is available.
- If the substance needs an assessment and depending on the chemical hazard assessment method chosen, a licensed GreenScreen profiler. The list of licensed profilers can be is found on the Clean Production Action website at, and a qualified ChemFORWARD assessor is found on the ChemFORWARD website.

- ~~A draft report per substance (not per product) is~~ Next, an extensive chemical hazard assessment will be assembled by the ~~licensed~~ profiler/assessor from the available information (literature search, structural similarity comparison, expert judgment) ~~covering human and environmental toxicology endpoints in accordance with GreenScreen or ChemFORWARD requirements~~
- ~~It is the licensed~~ The profiler ~~that/assessor~~ sets the benchmark ~~score/hazard band~~ per relevant substance, ~~which. The assessment report~~ is then valid for ~~at least~~ up to five years.
- Benchmark ~~Complete assessment~~ reports must be submitted to TCO Development for final approval before a substance is added to TCO Certified Accepted Substance List. ~~A copy must also be made available to CPA.~~
- When the ~~final approval is complete, TCO Development will add the~~ substance is added to the TCO Certified Accepted Substance List, ~~showing it shows only~~ the substance's name, CASRN, type, ~~of additive,~~ benchmark ~~score/hazard band~~, date of the assessment and profiler /assessor company name.
- Once a substance is added to the list and the environmental verifier identifies them, ~~then it,~~ they will issue the environmental verification ~~to the applicant (see above point 1: "If all flame retardants and plasticizers only include substances on~~

A substance being removed from TCO Certified Accepted Substance List ~~the procedure is as follows~~ is as follows ~~is as follows~~:

- When the validity of a GreenScreen/ChemFORWARD assessment (5 years) has expired and not been updated, TCO Development will consider that the substance is no longer being used on certified products. In this case, the substance will be moved to TCO Certified Potential Candidate List.
- If a substance benchmark/hazard band has been degraded during the 5 year validity to a non-accepted benchmark/hazard band, it must be removed. The substance can continue to be used for up to 18 months from the degraded date. The removal date will be visible on TCO Certified Accepted Substance List.

Applying for an extended period ~~of time~~ to substitute or add a substance to TCO Certified Accepted Substance List

Applicants signing the mandate ~~have the option to can~~ seek an extended period ~~of time in order~~ to complete assessments or substitute restricted substances ~~with unknown hazard levels~~. Upon request for an extension, the applicant ~~is required to~~ must complete a risk assessment questionnaire and submit it to TCO Development. The risk assessment requires

the applicant to clarify why an extension is necessary, provide information on the chemical and its substitute ~~in question~~, and include a timeline for ~~completing~~ the assessment and/or substitution ~~to be completed~~. If an extension application is not granted, the applicant ~~is required to~~ must ensure that all used flame ~~retardants~~ retardant, plasticizer or plasticizers stabilizer formulations only include substances ~~that are~~ on TCO Certified Accepted Substance List before an environmental verification can be issued for the product model ~~by an environmental verifier~~. If ~~the agreed an~~ extension due date is exceeded without conformity, ~~then~~ the ~~environmental~~ verifier must contact TCO Development and a course of action will be decided after discussing the issue with the applicant.

Draft 2

7.4 Plasticizers

Background

Plasticizers are increasingly associated with negative environmental and human health impacts. RoHs is a restricted substances list that, beginning in 2019, restricts the use of four phthalates. TCO Development is committed to ~~take~~[taking](#) a much broader approach by identifying and restricting not only these four, but all substances of high concern used in IT products. Our criteria are, therefore, designed to make sure that replacement substances are independently assessed as safer alternatives, and that transparency increases. The full list of safer alternatives is available on tcocertified.com.

This mandate uses the [chemical](#) hazard assessment and decision logic framework ~~called~~ GreenScreen® for Safer Chemicals, developed by the non-profit organization Clean Production Action (CPA), ~~and the ChemFORWARD hazard banding system based on the Cradle to Cradle~~ [Material Health Assessment Methodology](#).

GreenScreen criteria ~~are in line~~[align](#) with international standards and regulations that assess chemicals on their human health and environmental hazards. These include the Regulation on the classification, labelling and packaging of substances and mixtures (CLP), ~~the~~ Globally Harmonized System of Classification and Labelling of Chemicals (GHS), OECD testing protocols, European REACH Regulation that includes RoHs, POPs, SVHCs and the U.S. EPA's Design for Environment (DfE) Alternatives Assessment.

Definitions

Plasticizer: An additive to a polymer (plastic), to increase its flexibility, transparency, durability, or longevity.

Phthalates: The most common type of plasticizer in PVC cables.

Licensed ~~profilers~~[GreenScreen Profilers and ChemFORWARD qualified assessors](#): [Independent](#) toxicology firms licensed/[qualified](#) by CPA/[ChemFORWARD](#) to provide ~~GreenScreen~~ assessment services for a fee to clients.

TCO Certified Accepted Substance List: Public list of independently assessed safer available alternatives considering toxicity and functionality. ~~Available at~~.

~~Clean Production Action (CPA) Developers of GreenScreen® for Safer Chemicals~~,

Product housing is ~~considered~~ the external enclosure or casing that protects the [product's](#) internal parts ~~of the product~~. This includes the product stand.

[An](#) electronic component is considered an individual part or combination of parts that, when together, perform a design function(s) and are typically directly attached to a printed circuit board. Internal and external power supplies are not included in the definition.

[External cables delivered with the product: Cables that provide power to the product and connect the product to an external peripheral \(USB-USB, HDMI-HDMI, HDMI-DP, VGA-VGA, etc\).](#)

Applicability

All product categories.

References

7.4, 7.5, 7.6.

7.4.1 Mandate

- ~~Plasticizers used in~~ Product housing [above 0.5 grams](#) and cable and wire insulations must ~~have been assigned a GreenScreen benchmark score of 2, 3 or 4 by a licensed GreenScreen profiler and~~ [only contain intentionally added plasticizers that](#) appear on ~~the public~~-TCO Certified Accepted Substance List. ~~A benchmark U is only accepted when the “worst case scenario” for data gaps is considered to be a benchmark 2 or above.~~

Exempted are connectors and wires [sealed](#) inside electronic components.

- The product must not contain Bis (2-ethylhexyl) phthalate (DEHP), Butyl benzyl phthalate (BBP), Dibutyl phthalate (DBP), and Diisobutyl phthalate (DIBP).

No parts of the product are exempted.

All substances of a plasticizer mixture must be accounted for. Non-accepted ingredients must not exceed concentration levels of 0.1% by weight of the plasticizer.

Submit the following to an approved verifier:

- A completed and signed product form (chapter 11.3).

~~Submit~~ The following ~~together with the application~~ [is submitted](#) to TCO

Development:

- A copy of a verification report from a verifier approved by TCO Development.
- A document copy or access to a database copy of the complete assessment report conducted and issued by an approved GreenScreen licensed profiler.

7.4.2 Clarification

The mandate applies to ~~the~~ product housing, ~~above 0.5 grams.~~ There is no weight threshold for cable and wire insulations with no weight threshold. This includes internal and external power supply housing and ~~their~~ external cables ~~and.~~ Only wires. ~~Wires that are exempted are those enclosed inside completely sealed within an~~ electronic ~~components~~ component such as a HDD, SSD and ODD ~~are exempted.~~

Examples of cables and wires include: Internal product cables that interconnect between components and are detachable at both ends, such as power and data/signal cables. Cables permanently attached to electronic components, such as fans and speakers. External cables delivered with the product are considered cables provided to supply power to the product and connect the product to an external peripheral (USB-USB, HDMI-HDMI, HDMI-DP, VGA-VGA, etc).

TCO Development ~~and Clean Production Action (CPA)~~ must have access to a copy of the GreenScreen ~~and ChemFORWARD~~ assessment ~~report~~ reports before the substance can be added to TCO Certified Accepted Substance List. ~~Once this is done, the substance will be added to the list, available at.~~

For more clarifications on adding substances to TCO Certified Accepted Substance List; ~~conformity procedure, rules for adding a substance and applying for an extended period of time for substances not on the list, refer to clarifications under the mandate and accepted hazard assessment frameworks, see~~ non-halogenated substances 7.3 clarifications.

7.5 Hazardous substances in product packaging

Background

The use of hazardous substances in packaging materials is problematic and should be minimized. It poses a risk to human health and the environment, not least because packaging materials have a short lifespan and generate large volumes of waste. Several hazardous substances are regulated in many countries, and the use of them should be phased out.

Applicability

All product categories.

References

7.7.

7.5.1 Mandate

The packaging material must not contain lead (Pb), cadmium (Cd), mercury (Hg) or hexavalent chromium (Cr6). Plastic packaging material must not contain organically bound halogens.

Submit the following to an approved verifier:

- A completed and signed product form (chapter 11.3).

Submit The following ~~together with the application~~ is submitted to TCO Development:

- A copy of a verification report from a verifier approved by TCO Development.
-

7.5.2 Clarification

Limit values are according to Directive 94/62/EC on packaging and packaging waste.

8 Material Recovery

- More than 50 million metric tons of e-waste is generated every year and only a small amount is handled in a safe way.
- This leads to pollution, human health hazards and the loss of valuable finite resources.
- For a more sustainable life cycle, products and materials must be recovered and reused to a much larger extent.

Material waste – a multi-faceted sustainability issue

Today's unsustainable handling of e-waste leads to pollution, health hazards and the loss of valuable natural resources, such as copper, gold and rare earth metals. According to the United Nations University, electronic waste is the fastest growing waste stream in the world, with more than 50 million metric tons generated every year. It is estimated that only 20 percent of the waste is handled in a proper way. The rest is unaccounted for and risk being incinerated, placed on scrap heaps, or illegally exported to developing countries, often to destinations lacking effective legislation that regulates how e-waste should be managed. In these countries, products are manually disassembled, burned in the open air or dissolved in acid by local laborers including children, without adequate protective equipment – leading to severe health problems.

The packaging is also a sustainability issue. Packaging material has a short lifetime and generates large volumes of waste. Using several types of materials that are difficult to separate makes recycling a challenge.

Our approach: prevent e-waste and recover materials safely

The most important way of reducing e-waste is to use products longer. Read more about this in chapter 6. Once products have reached the end of their usable life, they must be collected for remanufacturing, refurbishing or recycling. Product packaging must be designed in a way that enables reuse and recycling.

Criteria in chapter 8 focus on:

- Saving natural resources and limiting hazardous waste by requiring that all packaging materials must be easily separable if not reusable.
- [Gathering information on which to increase the use of post-consumer recycled plastics in product packaging when it is not possible to substitute them with other non-plastic materials.](#)

- Ensuring that brand owners actively participate in e-waste reduction through offering product take-back schemes in all sales countries and utilizing a significant portion of certified reuse and recycling facilities ~~are used today, to prepare for future criteria on material recovery.~~

Draft 2

8.1 Product packaging

Background

Packaging is a well-known environmental problem that is regulated in many countries worldwide. Packaging material has a short lifetime and generates large volumes of waste.

[More than 50% of global waste ends up in landfills or open dumps.](#)

- [To reduce the waste generated by packaging materials, it shall be possible to separate them into single material types without the use of tools so that material can be recycled instead of becoming waste.](#)
- [Even for packaging materials that may be separated into single materials, little of the plastic is properly recycled. Plastics that degrade into microplastics should be prevented from entering landfills or waterways, as the incomplete degradation process leads to the accumulation of highly mobile microplastics in the environment.](#)

Definitions

Applicability

All product categories.

8.1.1 Mandate

- ~~Non-reusable~~[All parts of the packaging components](#) of the certified product weighing more than 25 grams must be possible to separate into single material types without the use of tools ~~in order for the material to be recycled.~~
- ~~Exempted is reusable packaging.~~
- [For product packaging solutions that are comprised of \$\geq 20\%\$ plastic, by weight of all packaging materials, the following must be fulfilled:](#)
 - [\$\geq 50\%\$ of the total plastic packaging must be composed of post-consumer recycled plastics, by weight.](#)

Submit the following to an approved verifier:

- A completed and signed product form (chapter 11.3)
- [Completed post-consumer recycled content template - packaging section.](#)

The following ~~information must be~~ submitted ~~with the application~~ to TCO Development:

- A copy of the verification report(s) from a verifier approved by TCO Development.

8.1.2 Clarification

~~A reusable package or container~~The following is designed for repeated reuse without impairments submitted to TCO Development and may be published:

- Total weight of its protective function. A take-back system~~all packaging materials~~
 - Total weight of all plastic content in the packaging solution
 - Total weight of post-consumer recycled plastic materials
 - Percentage of post-consumer recycled plastics
-

8.1.2 Clarification

Packaging solutions that contain more than one individual product are not covered by the mandate, such as bulk packaging solutions.

Document proof from the material vendor must also be provided for each part containing post-consumer recycled plastics if it is to be included in the PCR percentage.

If no proof exists, then 0% must be reported.

The following information must be submitted to an approved verifier

For each packaging part weighing more than 0,5g, the following must be reported in the "postconsumer recycled content & packaging template", packaging tab:

- Material Type
- Weight of part
- Weight of plastics in part
- Weight of PCR plastic content
- PCR material manufacturer name
- PCR material identifier

The post-consumer recycled content & packaging template is available for all end-users in order for packaging to be defined as reusable at tco-certified.com/certification-documents

8.2 E-waste management

Background

Enormous amounts of e-waste is generated every year. It is one of the world's fastest growing waste streams, and much of it is exported to developing countries, burdening local communities with this global problem. Unsafe handling of e-waste causes pollution, human health hazards and the loss of valuable, finite resources. The Basel Convention governs the export of many types of electronic waste, however, it is not properly implemented in all countries. To help reduce the e-waste problem, manufacturers need to provide mechanisms to take back their products. This is consistent with the principle of individual producer responsibility, where each manufacturer is financially responsible for managing its own branded products at end-of-use. The purpose of this criterion is to influence the expansion of better electronic waste management practices to more countries.

Applicability

All product categories.

8.2.1 Mandate

~~By the end of August each year, the brand owner must report the following for the previous calendar year on a global scale for each certified product. (This applies until one year after the certificate expires):~~

~~1. The number of certified products that were manufactured~~

~~The brand owner must annually complete the e-waste management template and prove that:~~

~~2. In all countries where the certified products were product is sold in~~

- ~~The name of, the brand owner offers product take-back system or extended producer responsibility schemes (EPRs) used for each country.~~
- ~~The name and address At least 40% of the all first-tier reuse_ and recycling facilities processing the collected products together with the standards met used by the facilities (i.e. non-EPR take-back systems are certified according to R2, e-Stewards, WEEE LABEX, EN50625, or equivalent).~~

Submit the following to an approved verifier:

- A completed and signed brand owner product form (chapter 11.4).
- Submit a filled-out TCO Certified E-waste management template covering the previous calendar year.

The following together with the application is submitted to TCO Development:

- A copy of the verification report(s) from a verifier approved by TCO Development.
 - The e-waste management template must be uploaded annually in TCO Certified Portal
-

8.2.2 Clarification

Instead of Reporting period

The reporting manufacturing volumes must be submitted by 31 August each year. Each reporting period is the previous calendar year. The reporting applies until one year after the certificate has expired.

Reporting and verification guideline

The brand owner must complete the E-waste template. In this template the brand owner will provide the following information:

1. The number of certified products that were manufactured.
2. The take-back volume of products (in numbers) by the brand owner for each certified product, reporting may be done by combining product category. (take-back carried out by EPRs systems, which is mandatory/approved by local law/government are excluded)
 - a. The number of products processed for Reuse
 - b. The number of products processed for Recycling
3. The name and weblink to all used take-back systems (EPR and non-EPR).
- 4.4. All countries in which the certified products within each product category were sold together with one take-back system covering the country.
- 2.5. Reuse The name and address of all first-tier reuse- and recycling facilities that are used by government approved EPRs are excluded from point 4 in the mandate- non-EPR take-back systems to process the products.
 - a. The certificates held by the first-tier reuse- and recycling facilities used to process the products. (i.e. R2, e-Stewards, WEEELABEX, EN50625, or equivalent.)

The e-waste management template can be found at <https://tcocertified.com/certification-documents/https://tcocertified.com/certification-documents/>

Clarification The number of sustainability performance indicator(s)

One or more “sustainability performance indicators” (chapter 1.3) are collected for this criterion. There is no mandatory level for these indicators but they must be verified and reported according to the description below.

The following SPI(s) is not required for compliance with TCO Certified. If no information is provided the product will receive the lowest classification by default.

Membership in multi-stakeholder initiatives working towards solving the problems connected to e-waste (Class A-C)

- **Class A:** Membership in a multi-stakeholder initiative working towards solving the problems connected to e-waste (i.e. StEP, PREVENT Waste Alliance, PAGE)
- **Class B:** No membership
- **Class C:** No information provided

Verification: The brand owner must provide documentation showing an active membership in a multi-stakeholder initiative working towards solving the problems connected to e-waste.

Use of internationally accredited reuse and recycling facilities (Class A-D)

Brand Owners use EPRs and/or reuse/recycling facilities that are certified to internationally accredited standards (R2, e-Stewards, EN50625 or equivalent):

- **Class A:** For all markets where certified products are sold, only internationally accredited EPRs and reuse/recycling facilities are used by the brand owner.
- **Class B:** For all markets where certified products are sold, internationally accredited reuse/recycling facilities (EPRs excluded) are used.
- **Class C:** Not all markets where certified products are sold are covered by accredited EPRs or reuse/recycling facilities.
- **Class D:** No markets where certified products are sold are covered by accredited EPRs or reuse/recycling facilities.

Verification: The data must be provided during the reporting at the end of August.

- For EPR systems:
 - a link to their public policy must be provided which must include their requirement on internationally accredited standards (R2, e-Stewards, EN50625 or equivalent).
- For reuse and recycling facilities:
 - a valid certificate for R2, e-Stewards, EN50625, or equivalent must be provided.

Ratio of compensated versus that were manufactured products (Class A-G)

For can be reported per product category applicability, see the corresponding TCO Certified Edge, E-waste compensation criteria document.

For this SPI, products have the possibility to be compliant with the model of TCO Certified Edge—E waste compensation without achieving the full 100% compensation threshold. The compensation must still follow the rules in TCO Certified Edge—E waste compensation:

- **Class A:** Fully compliant with TCO Certified Edge, E-waste compensated. (100%)
- **Class B:** 75% or above
- **Class C:** 50% or above
- **Class D:** 25% or above
- **Class E:** 10% or above
- **Class F:** 1-10%
- **Class G:** 0% or no information provided.

Verification: The brand owner must provide a verification of conformity report from an approved verification organization which follows the TCO Certified Edge, E-waste compensated rules.

For Part 2 - Point 1 - The take-back can be handled by an EPR or by the Brand owner.

8.3 Material coding of plastics

Background

The best way of reducing IT products' environmental impact is to extend product life through reuse. Once this no longer is possible, the materials must be recycled. By coding the plastic parts, recycling is made easier and the materials can be used in new products.

Definitions

Plastic parts are parts made mainly of plastics, e.g. the product housing. Parts containing other materials in any significant amounts, e.g. cables with metal conductors, are not included in the definition.

Printed wiring board laminate is a printed board that provides point-to-point connections but not printed components in a predetermined configuration on a common base.

Applicability

Displays, desktops, all-in-one PCs, projectors, servers, network equipment, data storage products, Imaging equipment.

References

8.1-8.3.

8.3.1 Mandate

- Parts made with a majority of plastics weighing more than 25 grams must be material coded in accordance with ISO 11469 and ISO 1043-1, -2, -3, -4.

Submit the following to an approved verifier:

- A completed and signed product form (chapter 11.3)

The following ~~information must be~~ submitted ~~with the application~~ to TCO

Development:

- A copy of a verification report from a verifier approved by TCO Development.
-

8.3.2 Clarification

Printed wiring board laminates, wires and cables, connectors, electronic components, optical components, acoustic components, ESD and EMI components are exempted from the mandate.

If the amount of flame retardant exceeds 1 % by weight, the coding must be complemented in accordance with ISO 1043-4.

The requirements also apply to plastics in the LCD panel, however, labeling of the light guide may instead consist of the application of a label in close proximity, for example PLASTIC LIGHT GUIDE:>*plastic type(s)*< or >PLASTIC LIGHT GUIDE:*plastic type(s)*<.

Labeling of plate diffuser (not thin plastic film diffuser) must follow the same rules as for the light guide. The requirement does not cover other thin plastic films in the panel due to difficulties in labeling these.

9 Test conditions for all-in-one PCs

9.1 General test conditions

9.1.1 Definition of a test object

- The products that are subject to tests within this product category are defined in the chapter "About this document".

9.1.2 Required information about the product

The applicant must specify:

- Name(s), type designation(s) and manufacturer for all exchangeable parts of the product.
- Display resolution and the vertical and horizontal frequencies for testing.
- Name, type designation and manufacturer of the graphics card. This information must be specified in the test report.

9.1.3 Test conditions

- The product must be delivered to the test facility in test ready condition and include any required accessories. All necessary information about how to operate and adjust the product must be provided.
- The performance of the tested product must in all aspects be equal to the product that is delivered to the end user.
- The measurement must be taken with the all in one PC in default CCT. If no default CCT is given or available the color temperature presented by the recall function (or equivalent function) in the On-Screen-Display. If no On-Screen-Display exists, the default CCT on start up must be used.
- The applicant must inform the test facility if any image enhancement software or hardware is used for the all in one PC, since this can influence the results.
- The product must be warmed up for at least 30 minutes or until it is stabilised. If the display is not stable within one hour, the engineer may cancel the test and demand a replacement sample.
- The screen surface must be clean when tested.
- The product must be tested under nominal conditions of input voltage, current, etc. If sold on different markets, the manufacturer must choose one setup which represents the conditions of the country where the largest number of products are sold.

- The product must be tested without load on any peripheral interface unless it is necessary in order to operate the product. For example, if the product relies on network connection to function, a network connection must be established.
- The product can be tested with or without a CD/DVD drive and does not need to have a built-in CD/DVD drive.

9.1.4 Product alignment for testing

The product display front must be aligned vertically with the possibility to rotate the screen $\pm 30^\circ$ around a vertical axis through the centre point of the screen front. It must also be possible to tilt the screen forwards and backwards $\pm 15^\circ$ around a horizontal axis through the same centre point.

9.1.5 Settings of the all-in-one PC

- Pivot screens must only be measured in the usual landscape mode.
- The all-in-one PC display resolution must be set to the native resolution.
- The all-in-one PC must be put in its factory default mode. The CCT of the default mode must be used.
- All tests must be performed with the all-in-one PC in the factory default mode if not stated otherwise in the test methods.
- Testing may be done with a preset instead of the default mode if the user is informed in the user manual which preset is used for compliance with the criteria in TCO Certified. In this case this preset must be treated as the default mode in the standard and noted in the test report.
- The settings must be the same for all tests, if not specified otherwise in the test method.
- An external control unit that is not a standard part of the all-in-one PC is not allowed.
- The color depth of the source signal must be 24 bits (8 bits per colour channel) or more.
- In Windows/Display Properties/Settings/Advanced, the Windows "Small fonts" option must be used.
- In Windows/Display Properties/Appearance the "Windows standard" color scheme option must be used.
- All settings in the operating system must be the default ones as delivered to the end user or the default as it appears directly after the installation of the operating system.

- Integrated automatic sensors and any eco mode functions enabled by default on the display must be disabled by the test engineer for all the tests, as long as the default CCT setting does not change.

9.1.6 Test image/test character

- All test images can be found on teocertified.com.
- The default testing 12 point Arial font and 100% “zoom/magnification” must be used. The latest version of MS Windows operating system is the default user interface, if not otherwise stated. For Macintosh PCs, Mac OS can be used during testing. The operating system most likely to be used by an end user should be used for testing.
- Another possibility is to use a testing program that must consist of software commonly used in office and home computer work. The word processor should be able to produce the text and graphics required for the test procedures.
- The default testing polarity is positive polarity (black characters on a white background).
- All parts of the tests for a test object must be conducted using the same font, character size, correlated color temperature, resolution, operating system and other settings of the all-in-one PC controls etc., unless otherwise stated in the test procedure.

9.1.7 Test image and test luminance setting

- The TCO Certified default test image (*figure 9.1.7*), has a 40 % image loading. The test image must fill the whole usable screen that represents the “full screen mode”. This image must be used for testing unless otherwise specified in the test procedure.
- If the measured display is not affected by image loading, alternative images may be used (described in *procedure* below) instead of the default test image for measurement of **Black level** and **Color gamut**, to minimize the contribution of stray light for some measurement equipment. If this method is selected, pay extra attention to displays with dynamic backlight as they may be affected by different levels of image loading.

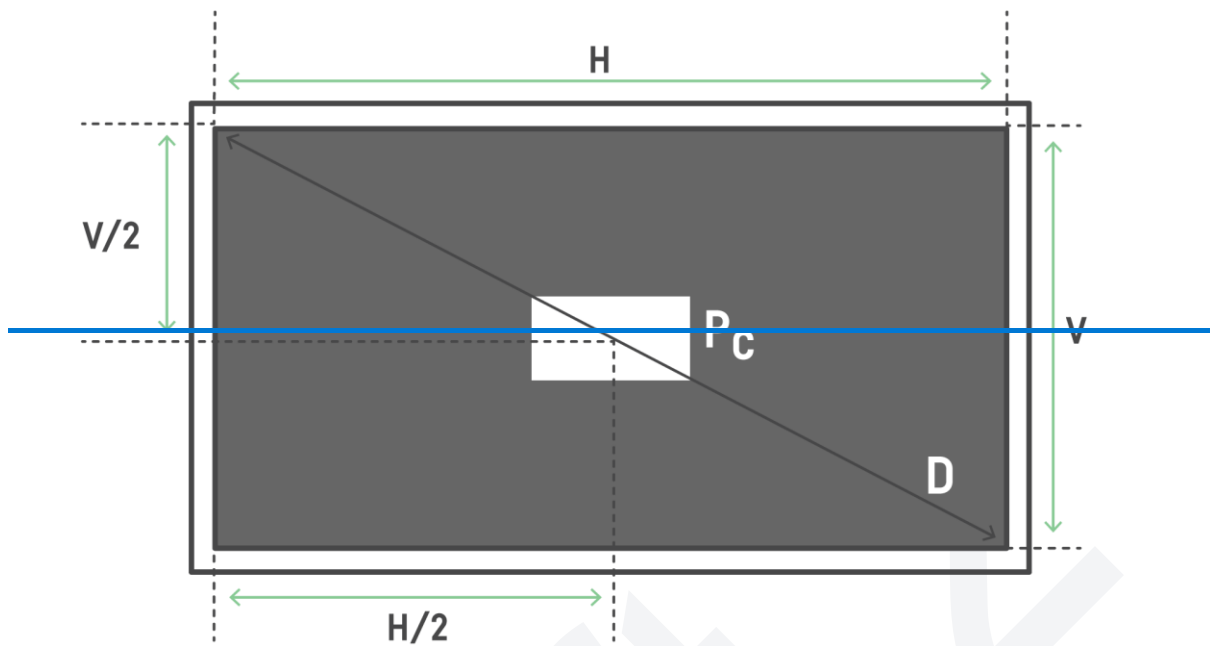

Figure 9.1.7 The TCO Certified default test image. H—horizontal size of the active area of the screen. V—vertical size of the active area of the screen.

Procedure

- The background color must be set to RGB 102,102,102 (i.e. equal to 40 % image loading).
- An active white measurement area at the centre of the screen must have a size that is 4% of the active screen size and have an RGB setting of 255, 255, 255.
- A permitted alternative to the 4% active screen size measurement area when testing Black level and Color gamut is to increase the measurement area to a size that is equal to 80% of the active screen size. The background must continue to be RGB 102, 102, 102.

Test luminance setting

- Reset the product to its default mode settings (as intended to be delivered to the end user). If the product has an automatic adjustment this can be activated once. In the default mode the luminance of the all-in-one PC display must be ≥ 150 cd/m². If the luminance is lower, then testing cannot proceed since the product does not conform with TCO Certified.

9.1.8 Instruments used for testing

All instruments used for testing must be calibrated and there must be a valid calibration report. Calibration must be done before the tests are carried out. Calibrations must be traceable to national standards.

9.1.9 Test report

The test results are valid only for the presentation form(s) and configuration(s) that are included in the test. However, configurations may be accepted by the test facility based on tests of a "worst case" configuration. In this case, it must be clearly specified in the test report which of the configurations that have been tested.

The test report must include the following information:

- Any changes to the test methods.
- The manufacturer, brand name, model type and serial number (if available).
- The supply voltage and frequency used during the test and whether it is a CLASS I or CLASS III type. If CLASS III the AC external power supply brand name and model number must also be stated.
- The degree of uncertainty for each given measurement result.
- Photographs of the product showing: front, rear and, if applicable, the external power supply with legible marking label.
- The panel brand name, full panel number, if the screen is pivot stand type and if it has a LED backlight.
- The mode(s) (i.e. horizontal and vertical scan frequency and resolution) used during the test and the aspect ratio.
- If applicable, the setting of contrast, brightness and CCT preset used during the test.

9.1.10 Overall uncertainty

The overall uncertainty of the test facility must be calculated for each measurement procedure in this document and presented in the test report. The uncertainty must be within the required levels for each criterion. All measurement uncertainties claimed for used instruments must be referred to traceable calibration reports.

About combining overall uncertainty values during test measurements:

- Criteria are fulfilled without adding or subtracting the overall measurement uncertainty.

- Report the value shown on the instrument without adding or subtracting the overall measurement uncertainty.
- The overall measurement uncertainty of the test facility must be printed in the test report together with the reported value.
- If a test facility has an overall measurement uncertainty higher than the one allowed by TCO Development for a certain criterion, then the test report for that criterion is not valid for certification and the test result will not be accepted by TCO Development.

9.2 Visual ergonomics

9.2.1 General test requirements

General test requirements are specified in section 9.1. During all tests, the display screen must be clean.

9.2.2 Photometric test facility general requirements

Photometric measurements must be performed under darkroom conditions. This means that measurement data must in no way be affected by direct light from sources or light reflected from interiors, equipment, clothes etc. The test facility must have a routine for the control of the stray light level at the all in one PC screen (see also 9.2.6).

9.2.3 Power supply and test room climate requirements for testing

- AC mains voltage* — 230 VAC RMS, tolerance δ 1 %
- AC mains frequency* — 50 Hz, tolerance δ 2 %
- Test room temperature — 23 ± 3 °C
- Humidity — 20-75 % RH (non condensing)

* or other voltage and frequency combination specified by the client.

9.2.4 Photometric and spectrometric measurements

Several instruments are to be used when carrying out measurements for visual ergonomics.

The following instrument types are to be used for testing:

- **Luminance meter.** A luminance meter must have a sufficiently good V_L -sensitivity (Requirements for luminance meters are covered by CIE Publication 69 (1987). Luminance meters of CIE Class L (laboratory) with a combined performance characteristic ≤ 3 % must be used) and integrate luminance over a finite measuring field during a finite time. The meter must be equipped with adjustable optics and always be focused on the measured area. The luminance meter must incorporate a

sufficiently long time constant of integration in order to ensure averaging of the pulsation of the light emitted by displays. The sensitivity must be independent of the polarization of the measured light (often referred to as f_s error).

The luminance meter measuring field must be one degree for all measurements, except for the micro-photometric luminance measurements, see below.

An automated instrument using collimating optics may be used for testing although the measurement area will differ somewhat from the area covered by the luminance meter. When the luminance measurement in this case is done at a shorter distance than $1.5 \times$ the screen diagonal (D) because of instrumental constraints, the facility must verify that the results are equal to those done at $1.5 \times D$.

- **Micro-photometer.** Micro-photometric registration of the luminance distribution of test patterns must be performed with an array photodetector device capable of resolving structures of ≤ 0.02 mm. A scanning device must not be used because it is sensitive to jitter and other variations that may occur during a scanning.
- **Spectroradiometer.** An instrument for the measurement of radiant flux as a function of wavelength must be used. A spectroradiometer for the measurement of light and color is normally equipped with a microprocessor that makes it possible to obtain luminance and color coordinates directly from raw measurement data. A spectroradiometer can replace the luminance meter when suitable. The wavelength resolution must be ≤ 4 nm for accurate color measurements. The sensitivity must be independent of the polarization of the measured light (often referred to as f_s error).

9.2.5 Measurement distance

All measurements must be carried out through a point, simulating the eye position of the operator, at a distance of $1.5 \times$ "diagonal of the screen" from the centre point of the display screen but no less than 500 mm which could be considered as an absolute minimum viewing distance for comfortably viewing the display. The instrument must be focused on the presented test image for all measurements.

9.2.6 Stray light

Stray light may cause errors which can negatively affect measurement of luminance, contrast and chromaticity coordinates. It is therefore necessary to make an evaluation of stray light influence for the different measurement procedures described in this document.

If it is verified that stray light affects the measurement result it is necessary to take actions to eliminate the source of error. Two possible ways to solve the problem are to equip the

luminance meter with a well designed screening attachment, a frustum or to use a black screening sheet at the display surface.

Draft 2

9.3 Emissions

9.3.1 General test requirements

General test requirements are specified in section 9.1. During all tests, the display screen must be clean.

9.3.2 Power supply and test room climate requirements for testing

- AC mains voltage* — 230 VAC RMS, tolerance $\leq 1\%$
- AC mains frequency* — 50 Hz, tolerance $\leq 2\%$
- Test room temperature — 23 ± 3 °C
- Humidity — 20-75 % RH (non-condensing)

The equipment must be connected to phase and neutral:

*— or other voltage and frequency combination specified by the client.

9.3.3 Product conditions and setup

- The tests must be performed with the full screen size activated.
- The all-in-one PC control settings must be the same as for visual ergonomics. This means that the default setting at reset must be used for the emission testing of alternating electric and magnetic fields the luminance at this setting must be ≥ 150 cd/m². See section 9.1.7 for details concerning this setting.
- The all-in-one PC must during the measurements show a full screen of capital "H" pattern in dark/black Arial letters on a luminated background (positive polarity), see section 9.1.6 for details concerning this setting.

Any pivot all-in-one PC that can be used in both normal landscape position and portrait position (turned 90°) must have measurements taken in both positions. The worst case must be reported.

Any all-in-one PC equipped with a height adjustable stand must have measurements taken in both the lowest and highest positions. Both measurements must be done with the measurement instrument positioned to the centre-centre point of the screen surface. The worst case must be reported.

If the all-in-one PC is connected to mains via a detachable mains cord, the measurement must be performed with a shielded mains cord (connected to earth for CLASS I device). Most shielded power cords have the text "shielded" printed on them. The quality of the shielding must be verified in the following way:

- Bend the cable in half and put the bended point of the cable in the centre of the turntable and both the connectors hanging down behind the turntable. Put the antenna 30 cm above and 30 cm in front of the centre of the turntable.
- Connect one side of the cable to mains and measure the alternating electric field of the cable. The values must be below (5.0 V/m in band I and 0.20 V/m in band II).

An all in one PC without an external power supply must be connected to mains via the above mentioned power cable. The power cable and signal cable must run from the points of connection on the product and then horizontally straight to a point 0.4 m behind the screen surface. The cables must then from this point run downwards at least 1 m. (See figure 9.3.3.1.) The power and signal cables may not be placed together unless the product is provided with an integrated cable holder. When an integrated cable holder is present it must be used for the test to secure the cables:

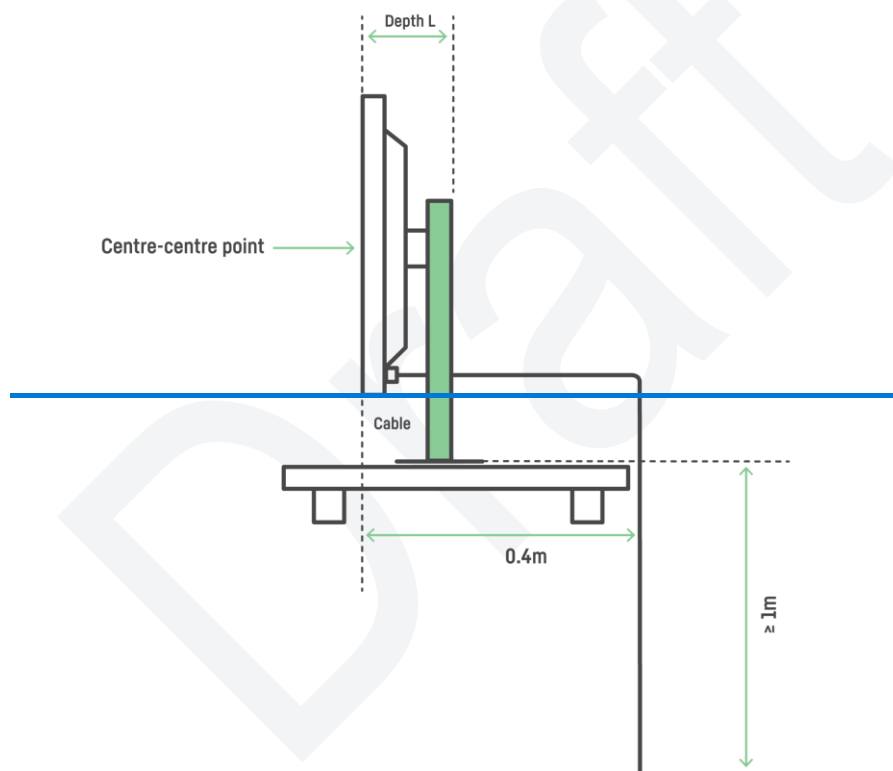

Figure 9.3.3.1. All in one PC without external power supply unit.

The external power supply unit, if any, will contribute to the electromagnetic fields around the all in one PC. Power supply units, which are connected via a primary cable to the outlet, must be positioned centrally, directly behind the test sample, on the turntable, with the secondary side towards the all in one PC, see figure 9.3.3.2. The primary cable must extend horizontally,

on the turntable to a point 0.4 m behind the screen surface. The cable must then, from this point run downwards at least 1 m. If the power supply can be positioned with different sides up, it must be tested in all positions and the worst case must be used. However, if it is obvious which side is intended to be the top side or bottom side by the placement of LED indicator or integrated supports to stand on, it is enough to test the power supply in the one intended position.

The secondary cable of the power supply must run the shortest distance from the point of its connection on the all in one PC to the secondary side of the power supply. The unused portion of the secondary cable, if any, must be bundled together with the power supply unit. The bundle loops must have a length equal to the longest dimension of the power supply. For supply units with dimensions less than 0.1 m, a 0.1 m bundle loop length must be used. For power supply units which are designed to be attached directly in the outlet without a primary cable, the secondary cable must in these cases run vertically down to the turntable from the point of its connection on the all in one PC and then horizontally straight to a point 0.4 m behind the screen surface. The cable must then, from this point, run downwards at least 1 m.

If the product bezel has an integrated external power supply holder, this must be used during the test and the cables placed according to the set up conditions for an all in one PC without external power supply as described above, if the product does not have an integrated cable holder. When an integrated cable holder is present then it must be used for the test to secure the cables.

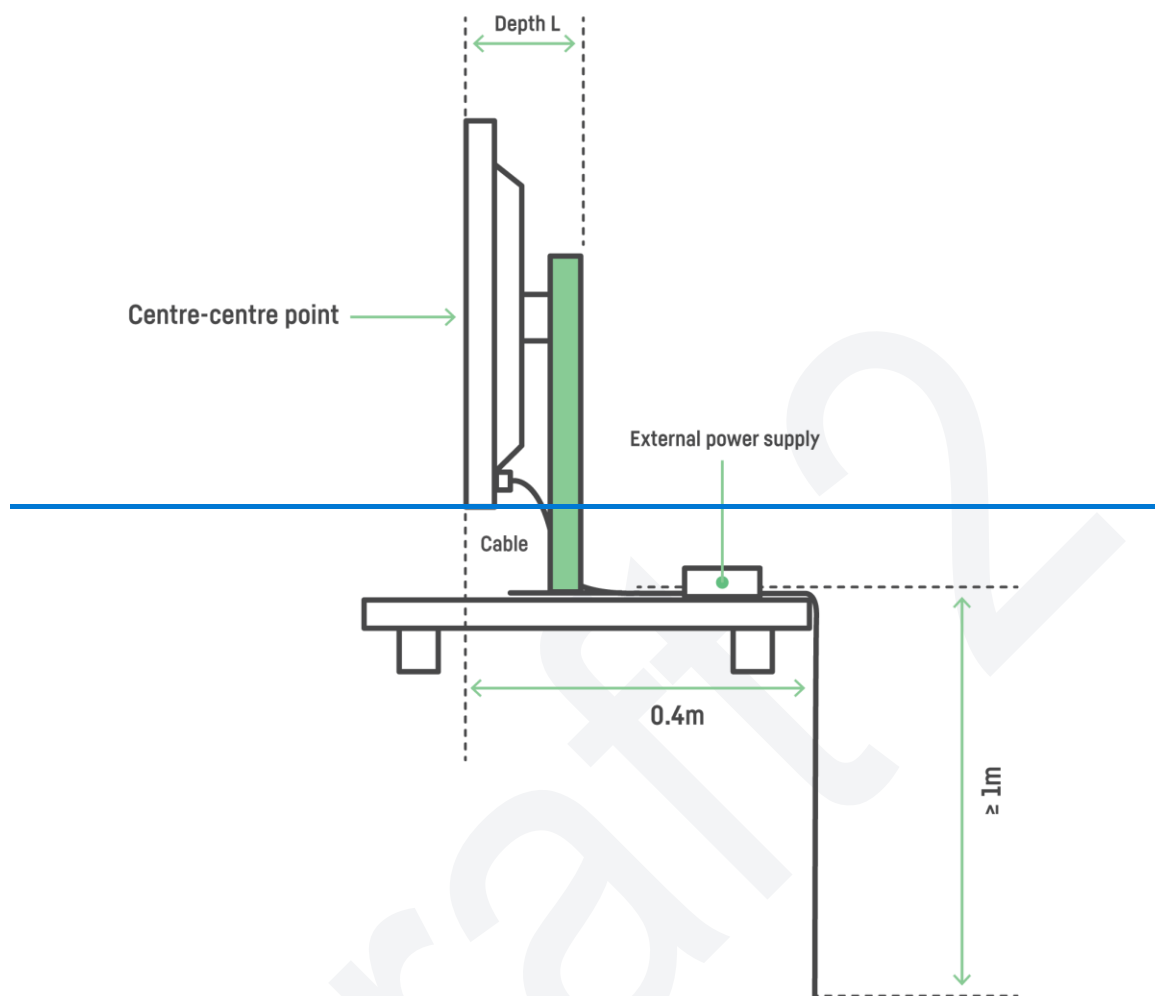

Figure 9.3.3.2. All in one PC with external power supply units.

Note! For pivot all in one PCs and those equipped with height adjustable stands, the cable has to be adjusted for the different positions:

For measurements of *alternating magnetic fields* the power cable need not be a shielded power cable and it may be positioned in another way, as the cable contributes a negligible amount to the magnetic field. However external power supplies must be correctly positioned, as they may give rise to magnetic fields:

If positioning according to the above rules is not possible, then the positioning of the external power supply and cables must be described in the test report.

9.3.4 Emission measurement instruments

The instruments used for emission testing must conform with the requirements and calibration procedures described below:

Alternating electric field meter

The alternating electrical field emission from the all in one PC under test must be determined by measuring the displacement current passing a given surface of the measuring probe. The probe consists of a disc of double sided printed circuit board laminate with a diameter of 300 mm. On the front of the board the copper layer is removed in the annulus between radii 50 and 52 mm (see figure 9.3.4.1):

The copper foil surrounded by the annulus is the active measuring surface. It is connected to one input terminal of an operational amplifier, with capacitive feedback. The other input terminal of the operational amplifier, the copper ring outside the active surface, and the back of the board are connected to ground. The output voltage (U) from the probe (active surface with area (A)) is related to the incident electric field, E, averaged over the active surface according to $U = \epsilon \cdot E \cdot A / C$ where C is the capacitance in the feedback loop of the operational amplifier and ϵ is the permittivity for a vacuum.

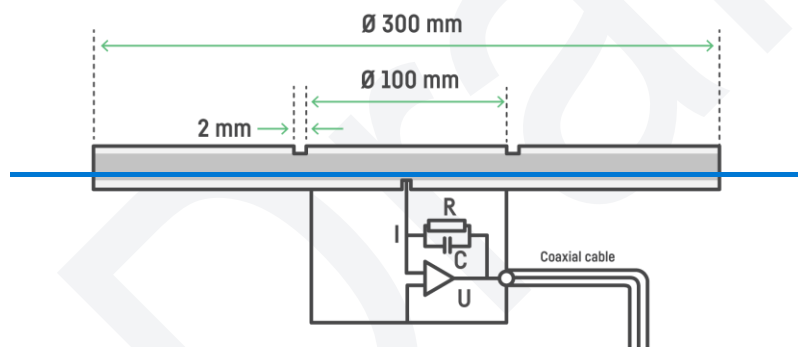

Figure 9.3.4.1 Sketch and circuit principle of the Alternating electric field meter for alternating electrical field measurements. The feedback circuit of the operational amplifier is a capacitance C in parallel with a high value resistor R to ensure that there is no DC voltage across the plates of the capacitor C.

The specifications for the frequency response of the measuring probe are given by the calibration procedure. The signals from the probe must be filtered by high pass and low pass filters. The specification of the filters is given in table 9.3.4.2

Table 9.3.4.2 Filter specifications

Frequency Band I					
Frequency	< 5 Hz	5 Hz	100 Hz	2 kHz	> 2 kHz
Attenuation	> 80 dB/decade	3 dB	0 dB	3 dB	> 40 dB/decade

Frequency Band II					
Frequency	< 2 kHz	2 kHz	30 kHz	400 kHz	> 400 kHz
Attenuation	> 80 dB/decade	3 dB	0 dB	3 dB	> 40 dB/decade

After amplification and filtering the output voltage of the measuring probe must be used to determine the r.m.s. value of the electric field strength in both frequency bands.

The measuring time must be sufficiently long to enable measurements with an accuracy of $\pm 5\%$ at 50/60 Hz.

The measuring system must be capable of measuring at least down to 2.0 V/m in band I and down to 0.20 V/m in band II.

The measuring probe must be calibrated using a parallel plate capacitor (air dielectric) consisting of the measuring probe and a metal plate of at least 300 mm diameter. The distance between the surface of the probe and the plate must be 30 mm.

The calibration must be performed with sinusoidal fields at the amplitudes and frequencies specified in table 9.3.4.3

Table 9.3.4.3. Calibration frequencies and amplitudes

	Frequencies	Amplitude
Band I	50, 100, 500, 1000 Hz	10, 25 V/m
Band II	15, 30, 60, 120 kHz	1.0, 2.5, 10 V/m

Recorded values at these calibration points must be within $\pm 5\%$ of the nominal value. Due to the nature of the specified filters the deviation must be calculated at 1 kHz from 9.5 and 22.5 V/m and at 120 kHz from 0.95, 2.4 and 9.5 V/m.

Alternating magnetic field meter in band I and band II

The magnetic field must be measured using coil systems that must consist of three mutually perpendicular concentric circular coils each with an area of 0.01 m^2 . The coils may depart from a circular shape where they intersect. The minimum inner diameter must be 110 mm and the maximum outer diameter 116 mm. The measuring coils must not be sensitive to electric fields.

The resonance frequency of each coil appropriately connected to cables and amplifiers must not be so low that it may influence the specified frequency response according to table 9.3.4.2. Amplifiers and integrating networks to make the output voltage proportional to the magnetic flux density and independent of frequency must follow each coil. The specifications in respect of the frequency response are given in the calibration procedure.

High pass and low pass filters must filter the signals from the coil systems. The specifications of the filters are given in table 9.3.4.2.

After amplification, integration and filtering, the signals from the three coils in each coil set must be used as input values for calculating the r.m.s. values of the amplitudes of the magnetic flux density vectors in both frequency bands. It is permissible to calculate the r.m.s. value for each of the coil signals and use the root of the squared sum of those r.m.s. values as the test result.

The measuring time must be sufficiently long to enable measurement with an accuracy of $\pm 5\%$ at 50/60 Hz.

The alternating magnetic field meter in band I and band II must be capable of measuring down to at least 40 nT in band I and down to 5.0 nT in band II.

The alternating magnetic field meter in band I and band II must be calibrated using a Helmholtz type calibration coil as shown in the figure 9.3.4.4. Calibration set up. Calibration must be performed with sinusoidal fields at the amplitudes and frequencies specified in table 9.3.4.2.

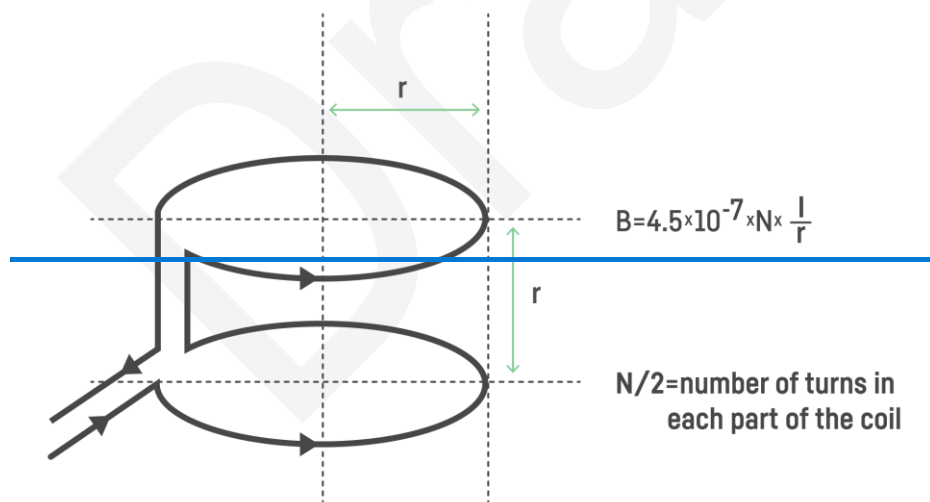

Figure 9.3.4.4. Calibration using a Helmholtz type calibration coil.

Table 9.3.4.5. Calibration frequencies and amplitudes

	Frequencies	Amplitudes
Band I	60, 100, 500, 1000 Hz	200, 2000 nT

Band-II	15, 30, 60, 120 kHz	25, 250 nT
---------	---------------------	------------

Recorded values for these calibrations must not deviate more than $\pm 5\%$ from the nominal value. Due to the nature of the specified filters the deviation at 1 kHz must be calculated from 180 nT and 1800 nT and at 120 kHz from 24 nT and 240 nT.

The calibration must be performed for each of the three individual coils separately exposed and for one situation where approximately the same flux density passes through all three coils:

Draft 2

9.3.5 Acoustic noise

The noise measurements must follow ISO 7779:2010 and must be reported according to ISO 9296:1988. (However, the principle for how the measurement uncertainty is handled must be the same as for all the other criteria in TCO Certified. This means that no uncertainty must be added to the result presented in the report.

In addition to reporting the measured A-weighted sound power level (LWA) in Bels (B) the single measurement values of the 9 measurement positions and the mean value of these A-weighted sound pressure level (LpA) in Decibels (dB) have to be included in the test report.

9.3.6 Overall uncertainty

The test must be performed in such a way that the total extended uncertainty in the test result will be less than $\pm 2.5\text{dB}$.

Note

The uncertainties given are worst case limits. In many cases it will be possible to obtain better accuracy.

10 References

International standard organizations referred to and their websites:

- ASTM, American Society for Testing and Materials;
- CIE, Commission Internationale de l'Eclairage, International Commission on Illumination;
- DIN, Deutsches Institut für Normung e. V.;
- EBU, European Broadcasting Union;
- IEC, International Electrotechnical Commission;
- ISO, International Organization for Standardization;
- ITU, International Telecommunication Union
- SMPTE, Society of Motion Picture Television Engineers;
- VESA, Video Electronics Standards Association;

1.1 — EN 60950-1 (IEC 60950-1). Safety of information technology equipment including business equipment.

2.1 — Responsible Business Alliance (RBA), <http://www.responsiblebusiness.org/>

2.2 — SA8000, <http://www.sa-intl.org>

2.3 — Amfori BSCI, <http://www.amfori.org/>

2.4 — <https://iccwbo.org/global-issues-trends/responsible-business/combating-corruption/>

2.5 — <http://www.oecd.org/corporate/mnc/mining.htm>

2.6 — EPRM: <https://europeanpartnership-responsibleminerals.eu/>

2.7 — RCI <http://en.cceme.org/en/news/58372.htm>

2.8 — RMI <http://www.responsiblemineralsinitiative.org/>

2.9 & 3.1 EMAS EU regulation no 761/2001 concerning the voluntary participation of industrial companies in the Union's environmental control and review structure.

2.10 — ISO 14001 Environmental management systems—Specification with guidance for use

2.11 — <https://www.bsigroup.com/en-GB/standards/>

2.12 — <https://www.iso.org/iso-45001-occupational-health-and-safety.html>

2.13 —

3.1 — EMAS EU regulation no 761/2001 concerning the voluntary participation of industrial companies in the Union's environmental control and review structure.

3.2 — ISO 14001 Environmental management systems—Specification with guidance for use

- 4.1 — EN 60950 (IEC 60950). Safety of information technology equipment including business equipment.
- 4.2 — ISO 7779:2010, Acoustics — Measurements of airborne noise emitted by computer and business equipment. This international standard is based on ECMA 74.
- 4.3 — ISO 3741:2010, Acoustics — Determination of sound power levels of noise sources using sound pressure — Precision methods for reverberation rooms.
- 4.4 — ISO 3744:2010, Acoustics — Determination of sound power levels of noise sources using sound pressure — Engineering method in an essentially free field condition over a reflecting plane.
- 4.5 — ISO 3745:2003, Acoustics — Determination of sound power levels of noise sources — Precision methods for anechoic and semi-anechoic rooms.
- 4.6 — ISO 11201:2010, Acoustics — Noise emitted by machinery and equipment — Measurement of emission sound pressure levels at a work station and other specified positions — Engineering method in an essentially free field over a reflecting plane.
- 4.7 — ISO 9296:1998, Acoustics — Declared noise emission values of computer and business equipment.
- 4.8 — Standard ECMA 74 8th edition, Measurement of Airborne Noise Emitted by Information Technology and Telecommunications Equipment.
- 4.9 — AFS, the Swedish Environment Authority's Provisions and General Recommendations 1998:5
- 4.10 — DIN 33402
- 4.11 — EC Directive 90/270/EEC EU Directive 90/270/EEC Minimum safety and health requirements for work with display screen equipment.
- 4.12 — ISO 11226 Ergonomics — Evaluation of static working postures
- 4.13 — ISO 13406-2 Ergonomic requirements for work with visual displays based on flat panels — Part 2: Ergonomic requirements for flat panel displays. International Organisation of Standardisation.
- 4.14 — ISO 9241-3 Ergonomic requirements for office work with visual display terminals (VDTs) — Part 3: Visual display requirements. International Organisation of Standardisation, 1992
- 4.15 — ISO 9241-5 Ergonomic requirements for office work with visual display terminals (VDTs) — Part 5: Workstation layout and postural requirements. International Organisation of Standardisation.
- 4.16 — Nymans, Berns, Gelin 1995, research report "Do AM-LCD monitors offer better ergonomic solutions than CRTs?"
- 4.17 — Statshälsan 1990, User recommendations from the Swedish Foundation of

- Occupational Health for State Employees, report “Man, Monitor and Work Environment”
- 4.18—UK Department of Trade and Industry, Consumer Safety Unit, Adult data DTI/Pub 45/3k/01/00/NP
- 4.19—VESA Flat Panel Monitor, Physical Mounting Interface Standard (FPMPMI), version 2.0, Revision 3, March 1, or VESA Flat Display Mounting Interface Standard, (FDMI) Version 1 October 28, 2002 which replaces and supersedes FPMPMI.
- 4.20—Humanseal 1/2/3, Niels Diffrient, Alvin R Tilley, Joan C Bardagjy. 1974
- 4.21—MOD, Defence standard 00-250. Human Factors for Designers of systems Part 3 (section 13—The workplace)
- 5.1—ENERGY STAR® Program Requirements for Computers
- 5.2—International Efficiency Marking Protocol for External Power Supplies
- 5.3—ISO 9241-3 Ergonomic requirements for office work with visual display terminals (VDTs)—Part 3: Visual display requirements. International Organisation of Standardisation, 1992
- 5.4—Flat Panel Display Measurements Standard, (FPDM), Version 2.0, VESA—Video Electronics Standards Association Display Metrology Committee. June 1, 2001, CA 95035, Milpitas.
- 5.5—ISO 13406-2 Ergonomic requirements for work with visual displays based on flat panels—Part 2: Ergonomic requirements for flat panel displays. International Organisation of Standardisation.
- 5.6—Bilissi, E., Jacobson, R. E., and Attridge, G. G (2008): “Just noticeable gamma difference and acceptability of sRGB image display on a CRT monitor, Imaging Technology Research Group, University of Westminster, Harrow, UK, The Imaging Scientist Journal Vol 56, 189-200.
- 5.7—CIE Publication 69 (1987), Methods of characterizing illuminance meters and luminance meters: performance characteristics and specifications.
- 5.8—ISO 3664:1999. Viewing conditions for graphic technology and photography, p. 10 Monitor luminance.
- 5.9—Barten, P.G.J., (1999) Contrast sensitivity of the human eye and its effects on image quality, SPIE Optical Engineering Press p. 179.
- 5.10—Wyszecki, G., Stiles, W.S., (1982) Colour Science: Concepts and methods, quantitative data and formula, Second Edition, John Wiley & Sons, Inc. Chapter 7, Visual thresholds, pp 567-569.
- 5.11—Le Grand, Y. (1957). Light, colour and vision. Chapman and Hall, p. 119
- 5.12—ISO 3664:1999, Viewing conditions for graphic technology and photography, p. 9 Uniformity of screen luminance.

- 5.13—Barten, P.G.J., (1999) Contrast sensitivity of the human eye and its effects on image quality, SPIE Optical Engineering Press p. 179—181
- 5.14—Le Grand, Y. (1957). Light, colour and vision. Chapman and Hall, Chapter 11, Luminance difference thresholds, p. 261.
- 5.15—Le Grand, Y. (1957). Light, colour and vision. Chapman and Hall, Chapter 11, Luminance difference thresholds.
- 5.16—Barten, P.G.J., (1999) Contrast sensitivity of the human eye and its effects on image quality, SPIE Optical Engineering Press
- 5.17—Barten, P.G.J., (1999) Contrast sensitivity of the human eye and its effects on image quality, SPIE Optical Engineering Press p. 105—106. (ISBN 0-8194-3496-5)
- 5.18—Kokoschka S. (1986). Visibility aspects of VDUs in terms of contrast and luminance. Behaviour and information technology. vol.5, No. 4, pp 309-333.
- 5.19—Wyszecki, G., Stiles, W.S., (1982) Colour Science: Concepts and methods, quantitative data and formula, Second Edition, John Wiley & Sons, Inc. Chapter 7, Visual thresholds, pp 574-575.
- 5.20—ITU-R Recommendation BT.709-5: Parameter values for the HDTV standards for production and international programme exchange
- 5.21—E.B.U. Standard for chromaticity tolerances for studio monitors Tech. 3213-E August 1975.
- 5.22—SMPTE 170M-1999 Television—Composite Analogue Video Signal—NTSC for Studio Applications.
- 5.23—Hunt, R.W.G. Measuring colour. 3rd edition (1998), Kingsley Upon Thames: Fountain Press.
- 5.24—Shimodaira, Y. et al., (1995), "Acceptable limits of gamma for a TFT liquid crystal display on subjective evaluation of picture quality" Consumer Electronics, IEEE Transactions Volume 41, Issue 3, 550-554.
- 5.25—Poynton, C. (2003), Digital video and HDTV Algorithms and interfaces, Morgan Kaufmann Publishers, An Imprint of Elsevier Science. Chapter 23 Gamma sRGB transfer function page 267 to 269. ISBN 1-55860-792-7
- 5.26—CIE Publication 15.2 (1986), Colorimetry, p. 11, p.27-28 and p. 53-54, table 1.3).
- 5.27—Roberts, A., Eng, B., (1995) "A method for the calculation of tolerances for display primary chromaticity coordinates" Research and development Department, Technical Resources, The British Broadcasting Corporation.
- 5.28—Le Grand, Y. (1957). Light, colour and vision. Chapman and Hall, pp 278-279.
- 5.29—Fairchild M. D. (1995), "Considering the surround in device independent colour imaging". www.eis.rit.edu/people/faculty/fairchild/PDFs/Bart.pdf
- 5.30—<http://www.w3.org/Graphics/Color/sRGB.html>

- 5.31— SMPTE RP-145-1994: SMPTE-C Colour Monitor Colorimetry
- 5.32— IEC 61966-2-1 (1999-10) Multimedia systems and equipment—Colour measurement and management—Part 2-1: Colour management—Default RGB colour space—sRGB.
- 5.33— ITU-R Recommendation BT.470-6: Conventional television systems.
- 5.34— ISO-TC130 WD-12646 p. 5 Section 4.7 Chromaticity and luminance of the white and black points and tracking.
- 5.35— ISO 3664:1999, Viewing conditions for graphic technology and photography, p. 5, 4.2.4 Surround and backing for reflection viewing, Note 1 p. 8.
- 5.36— Schenkman, B., and Kjelldahl, L. (1999). Preferred colour temperature on a colour screen. *Displays*, 20, 73–81.
- 5.37— www.srgb.com
- 5.38— Le Grand, Y. (1957). *Light, colour and vision*. Chapman and Hall.
- 5.39— Le Grand, Y. (1957). *Light, colour and vision*. Chapman and Hall, Chapter 12, Colour difference thresholds p. 279.
- 5.40— ISO 9241-8 Ergonomic requirements for office work with visual display terminals (VDTs)—Part 8: Requirements for displayed colours. International Organisation of Standardisation.
- 6.1— Tecchio, P., Ardente, F., Marwede, M., Christian, C., Dimitrova, G. and Mathieux, F., Analysis of material efficiency aspects of personal computers product group, EUR-28394 EN, Publications Office of the European Union, Luxembourg, 2018, ISBN 978-92-79-64943-1, doi:10.2788/89220, J
- 6.2— Ben Bridgens, Kersty Hobson, Debra Lilley, Jacquetta Lee, Janet L. Scott, Garrath T. Wilson, Closing the Loop on E-waste: A Multidisciplinary Perspective, *Journal of Industrial Ecology*, 2017
- 6.3— (EU Directive 2012/19/EU) Available at: <http://eur-lex.europa.eu/legal-content/EN/TXT/PDF/?uri=CELEX:32012L0019&from=EN>
- 6.4— Peter Keil, Simon F. Schuster, Jörn Wilhelm, Julian Travi, Andreas Hauser, Ralph C. Karl, and Andreas Jossen Calendar Aging of Lithium-Ion Batteries: I. Impact of the Graphite Anode on Capacity Fade *Journal of the Electrochemical Society* 2016-163: A1872-A1880.
- 6.5— http://batteryuniversity.com/learn/article/capacity_loss
- 6.6— http://batteryuniversity.com/learn/article/battery_definitions
- 6.7— Directive 2008/98/EC of the European Parliament and of the Council of 19 November 2008 on waste and repealing certain Directives (Text with EEA relevance) OJ L 312; 22.11.2008, p. 3–30 (BG, ES, CS, DA, DE, ET, EL, EN, FR, IT, LV, LT, HU, MT, NL, PL, PT, RO, SK, SL, FI, SV) Special edition in Croatian: Chapter 15 Volume 034 P. 99–126

7.1 — ~~EU Directive 2006/66/EC on batteries and accumulators containing certain dangerous substances~~

7.2 — ~~EU Directive 2011/65/EC on the restriction of the use of certain hazardous substances in electrical and electronic equipment~~

7.3 — ~~Regulation concerning Registration, Evaluation, Authorisation and Restriction of Chemicals (REACH), EC 1907/2006~~

7.4 — ~~GovTrack.us. "H.R. 4040 — 110th Congress (2007): Consumer Product Safety Improvement Act of 2008, GovTrack.us (database of federal legislation) . Retrieved 14 August 2009. → <https://echa.europa.eu/sv/home> — NEW~~

7.5 — ~~ECHA Website — Proposal for identification of Substances of Very High Concern → <http://eur-lex.europa.eu/homepage.html> — NEW~~

7.6 — ~~<https://www.greenscreenchemicals.org/>~~

7.7 — ~~Directive 94/62/EC on packaging and packaging waste.~~

8.1 — ~~EU Directive 67/548/EEC on the approximation of laws, regulations and administrative provisions relating to the classification, packaging and labelling of dangerous substances~~

8.2 — ~~ISO 11469:2000 Plastics — Generic identification and marking of plastics products~~

8.3 — ~~ISO 1043 1, 2, 3, 4 Plastics — Symbols and abbreviated terms~~

8.4 — ~~EU Directive 2002/96/EC on waste electrical and electronic equipment (WEEE)~~

11 Forms and signatures for application

All forms must be completed, signed and sent to a verifier approved by TCO Development.

The forms in this chapter are for reporting conformity with the mandates in TCO Certified, generation 9, for all-in-one PCs and for providing information about the brand owner management systems, the product and its manufacture.

Draft 2

11.1 Brand owner form

The information in this form refers to the brand owner. The form may cover several of the brand owner's products. The form must be submitted once a year.

11.1.1 Supply chain responsibility (mandate 2.1.1)

The most recent version of the brand owner's public code of conduct is attached (yes/no)	
Information on the routines of how management and workers have been informed about the brand owner's code of conduct is attached (yes/no)	
Supply chain responsibility mandate is fulfilled (yes/no)	

11.1.2 Supply chain transparency (mandate 2.2.1)

Name, title, telephone number and email address of the SMR on the TCO Certified portal (yes/no)	
The report from the SMR interview including the verified self assessment questionnaire (SAQ) is attached (yes/no)	
A date, with a period of less than 12 months, of the planned SMR interview with the name of the approved verifier on the TCO Certified portal (yes/no)	
Supply chain transparency mandate is fulfilled (yes/no)	

11.1.3 Anti-bribery management system (mandate 2.3.1)

An ISO 37001 certificate(s) is attached, or a booked date for the self assessment questionnaire (SAQ) and follow up interview. (yes/no)	
Anti corruption management mandate is fulfilled (yes/no)	

11.1.4 Responsibly sourced minerals (mandate 2.4.1)

The most recent version of the public policy and a description of how it is communicated to the supply chain is attached (yes/no)	
A description of the brand owner's structured work on identifying risk areas in their supply chain is attached (yes/no)	
The responsibly sourced minerals template is completed and submitted to TCO Certified Portal before the brand owner annual due date stated on the portal. (yes/no)	
Responsibly sourced minerals mandate is fulfilled (yes/no)	

The brand owner guarantees that the provided information in chapter 11.1 is correct, and accepts to be bound by the listed mandates as they are fully stated in TCO Certified, generation 9, for All in one PCs:

.....
.....
Product brand name Model name(s) or "All certified products"

.....
.....
Signature Name and title in block capitals

.....
.....
Date Brand owner company

Draft 2

11.2 Factory form

The information in this form refers to the factory where products included in the application are manufactured. The form may cover several of the brand owner's products. A separate copy of the form must be used for each factory.

11.2.1 Supply chain responsibility (mandate 2.1.1)

The supply chain identification template is completed and submitted before the due date stated on TCO Certified Portal (yes/no)	
---	--

11.2.2 Process chemicals management (mandate 2.5.1)

A copy of the ISO 45001 certificate is submitted before the due date stated on TCO Certified Portal (yes/no)	
The Process Chemical Data Collection (PCDC) Tool is completed and submitted before the due date stated on TCO Certified Portal. (yes/no) The PCDC Tool can be downloaded at teocertified.com	
Process chemicals management mandate is fulfilled (yes/no)	

11.2.3 Environmental management system (mandate 3.1.1)

A copy of the ISO 14001 certificate is submitted before the due date stated on TCO Certified Portal (yes/no)	
--	--

Energy efficiency indicators (mandate 3.2.1)

Total energy consumption for the factory. (KWh/Year)	
Percentage of renewable energy consumed by the factory (%)	
Energy improvements compared to previous year (%)	

11.2.4 Energy management system (mandate 3.3.1)

A copy of the ISO 50001 certificate is submitted before the due date stated on TCO Certified Portal (yes/no)	
--	--

The applicant guarantees that the provided information in chapter 11.2 is correct, and accepts to be bound by the listed mandates as they are fully stated in TCO Certified, generation 9, for all in one PCs.

.....
.....
Factory name _____ Factory address _____

.....
Applicant Name and title in block capitals

.....
Signature Date

Draft 2

11.3 Product form

The information in this form refers to the product that is included in the application. A separate copy of the form must be used for each product model.

11.3.1 Information to end users (mandate 1.1.1)

<p>mandate fulfilled through (A.1, A.2 or A.3):</p> <p>A. The information document for end users must be written in English or in the local language of the country where the product is to be sold. It must accompany the product in at least one of the following ways:</p> <ol style="list-style-type: none"> 1. As a separate printed or digital document. 2. Included in a printed or digital user manual. 3. As a separate digital document that is hosted on the brand owner's website. A direct link to the document must be included in the printed or digital user manual mentioned above. 	
<p>Information to end users mandate is fulfilled (yes/no)</p>	

11.3.2 Product specification (mandate 1.2.1)

Product manufacturer	
Product brand name	
Product brand owner	
Product type/model name	
Panel(s) screen size (inch)	
Total weight of the typical product configuration and power supply (kg)	
<p>A list of all panels with the following information is attached (yes/no)</p> <ul style="list-style-type: none"> Manufacturer Model/type Resolution Backlight Panel type 	

A list of all external power supplies with the following information is attached (yes/no) Manufacturer Model/type Rating Class	
A copy of the marking label is attached (yes/no)	
Product may be delivered without stand (yes/no)	
Product specification mandate is fulfilled (yes/no)	

11.3.3 Sustainability performance (mandate 1.3.1)

Sustainability performance mandate is fulfilled (yes/no)	
--	--

11.3.4 Non-mandatory sustainability performance indicators (mandate 1.3.1)

(SPIs marked with Z in criterion 1.3)

To achieve a higher classification on the following SPIs, additional information and evaluation is required. The submissions and additional evaluations are optional. By submitting and performing an evaluation, the product will always receive a higher classification than if no evaluation is conducted.

3.5 Documentation on PCF methodology is submitted (yes/no)	
3.5 Documentation regarding PCF availability is submitted (yes/no)	
6.1 Documentation on extended warranty availability is attached (yes/no)	
6.1 Documentation on public repair policy is attached (yes/no)	
6.2 Should the SPI "Classification of fasteners and connectors" be evaluated? (yes/no)	
6.2 Should the SPI "Necessary tools for repair/upgrade" be evaluated? (yes/no)	
6.2 Should the SPI "Classification of availability of spare parts by target group" be evaluated? (yes/no)	
6.2 Should the SPI "Classification of availability of spare parts by duration of availability" be evaluated? (yes/no)	
6.2 Should the SPI "Classification of availability of comprehensive information" be evaluated? (yes/no)	

8.2 Documentation showing the brand owner involvement in multi-stakeholder initiatives working towards solving the problems connected to e-waste is submitted (yes/no)	
8.2 Documentation on ratio of compensated versus manufactured products is submitted (yes/no)	

11.3.5 Post-consumer recycled content (mandate 3.4)

TCO Certified PCR template may be used for submission for this criterion

Documentation on weight of post-consumer recycled plastic parts is attached (yes/no)	
Documentation on weight of all plastic parts is attached (yes/no)	
Documentation on weight of post-consumer recycled non-plastic parts is attached (yes/no)	
Post-consumer recycled content mandate is fulfilled (yes/no)	

11.3.6 Electrical safety (mandate 4.1.1)

A copy of a valid CB certificate or a national certificate from a CB member (NCB) for the product is attached (yes/no)	
--	--

11.3.7 Acoustic noise (mandate 4.4.1)

A copy of the test report(s) from a laboratory accredited according to ISO 17025 is attached (yes/no)	
---	--

11.3.8 Vertical tilt (mandate 4.5.1)

Vertical tilt mandate is fulfilled (yes/no)	
---	--

11.3.9 Vertical height (mandate 4.6.1)

Vertical height mandate is fulfilled (yes/no)	
---	--

11.3.10 Energy efficiency (mandate 5.1.1)

A copy of the test report(s) from a laboratory accredited according to ISO 17025 is attached (yes/no)	
Energy efficiency mandate is fulfilled (yes/no)	

11.3.11 Standardized connectors (mandate 6.3.1)

Standardized connectors mandate is fulfilled (yes/no)	
---	--

11.3.12 Secure data removal (mandate 6.4.1)

Mandate fulfilled through (1,2,3,4,5 or 6)	
For 2 or 3 a link to the media sanitization software on the brand owners website is attached (yes/no)	
Secure data removal mandate is fulfilled (yes/no)	

11.3.13 Hazardous substances

7.1.1 Heavy metals mandate is fulfilled (yes/no)	
7.2.1 Halogens mandate is fulfilled (yes/no)	
7.2.3 A copy of the test report(s) from a laboratory accredited according to ISO 17025 is attached (yes/no)	
7.3.1 Non-halogenated substances mandate is fulfilled (yes/no)	
7.4.1 Plasticizers mandate is fulfilled (yes/no)	
7.5.1 Hazardous substances in product packaging mandate is fulfilled (yes/no)	

11.3.14 Material recovery

8.1.1 Product packaging mandate is fulfilled (yes/no)	
---	--

The applicant guarantees that the provided information in chapter 11.3 is correct, and accepts to be bound by the listed mandates as they are fully stated in TCO Certified, generation 9, for all in one PCs.

.....
Product brand name _____ Model name(s) _____

.....
Signature _____ Name and title in block capitals _____

Date

Applicant

Draft 2

11.4 Brand owner product form

The information in this form refers to the product that is included in the application.

The form may be signed once and cover all products, but a copy of the form must be attached to each application.

11.4.1 Product warranty (mandate 6.1.1)

Information about the minimum product warranty period for the product is attached (yes/no)	
Product warranty—brand owner mandate is fulfilled (yes/no)	

11.4.2 Replaceable components (mandate 6.2.1)

A link to the service manual on the brand owner website or a pdf of the material that will be published there during the validity of the certificate is attached (yes/no)	
Replaceable components mandate is fulfilled (yes/no)	

11.4.3 E-waste management (mandate 8.2.1)

E-waste management mandate is fulfilled (yes/no)	
--	--

11.4.4 Factory identification (mandate 2.1.1)

The final assembly factory/factories that manufacture the certified product are reported at the time of application (yes/no)	
The most recent independent audit and a CAP for each non-conformity was/is provided for the factory (yes/no)	

The brand owner guarantees that the provided information in chapter 11.4 is correct, and accepts to be bound by the listed mandates as they are fully stated in TCO Certified, generation 9, for all in one PCs.

.....

Product brand name _____ Model name(s) or "All products"

.....

Signature

Name and title in block capitals

.....

.....

Date

Company

Draft 2

11.5 Certification documents

The process chemical data template, self-assessment questionnaire and other relevant documents are available on:

All changes or clarifications made to this document are announced in the “technical updates and changes” newsletter. All previous changes communicated through the newsletter can be found on

Draft 2



Draft 2

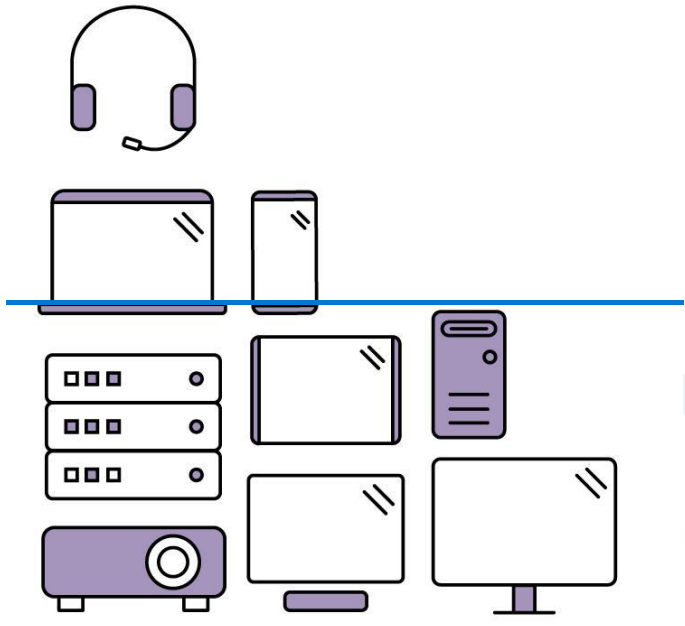

Draft

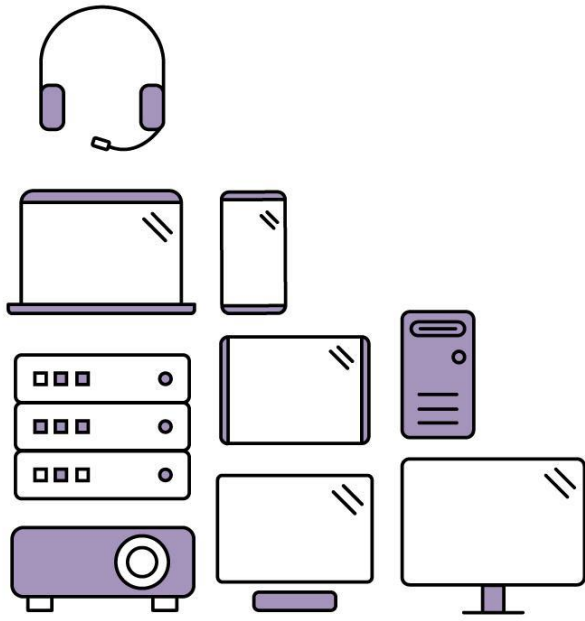

Draft 2