

TCO Certified, generation 10, for tablets



TCO Certified – driving sustainable development in IT products

Established in 1992, TCO Certified is a global sustainability certification for IT products. The organization behind TCO Certified is TCO Development. Certificates are valid worldwide and can be used as proof in all countries, without the need for local adaptation. TCO Certified is available with product-specific criteria for several product categories. TCO Certified is also available with only the general criteria for any IT product after consultation with TCO Development.

Comprehensive criteria with a life cycle perspective

Certified products must meet comprehensive environmental and social criteria throughout the life cycle. The criteria are science-based and developed in an open process with TCO Development's international network of stakeholders, which includes users, buyers, industry, NGOs, researchers and subject matter experts. To address the most pressing sustainability challenges and stay current with the latest technology developments, a new generation of TCO Certified is released every three years.

A third-party certification independently verified

TCO Certified is a third-party certification, independent of the IT industry and buyers. It meets the requirements in ISO 14024 Ecolabel Type 1 and has been approved by the [Global Ecolabelling Network](#) as part of the GENICES peer review process. Independent verification organizations, accredited to ISO 17025, verify that products conform with all criteria in TCO Certified. Verification is done both before and after certification, throughout the full validity period of the certificates.

How to apply for certification

At tcocertified.com, you'll find a guide that explains the certification process and lists what you need to do to apply for certification of your products. Compliance with all criteria in TCO Certified is independently verified. It generally takes three to five weeks to receive the certificate, once all documents and the product sample are delivered to the verification organization.

Need help?

Need help getting started? Or, would you like us to explain the certification process in more detail? Our certification team is always here to help. Email us on certification@tcodevelopment.com. Our approved, independent verifiers around the world are also at your disposal, and are able to explain the criteria and certification process in your local language. Contact details are available at tcocertified.com.

About this document

This is TCO Certified, generation 10, for tablets, released in December 2024. Other common names for a tablet is tablet computer or slate computer. A tablet is defined as a portable computer with a display size > 7", that is primarily for battery mode usage and has a touch screen interface. This means that connection to mains via an adapter is considered to be mainly for battery charging purposes and the onscreen virtual keyboard or a digital pen is in place of a physical keyboard. However, external keyboards are available for tablets, some of which function as docks for the devices. If a detachable keyboard docking station is supplied together with the tablet for the intention of the product being converted to a notebook computer, then the product must be tested according to TCO Certified, generation 10, for notebooks. All external cables and external power supplies are considered a part of the tablet.

The criteria include:

Mandate: A description of the requirements that need to be fulfilled, and how conformity is verified.

Definitions: Explanations of important terms relevant to the criterion.

References: References to sources.

Clarifications: Further details and explanations of the mandate.

Compliance with criteria is independently verified

Compliance with the criteria is verified by verification organizations (verifiers) independent of both the certification body (TCO Development), the applicant and the brand owner. Each criterion includes a description of the proof that must be submitted to the verifier, and to TCO Development together with the application form. This may be a test report or a verification report:

1. A test report presents the results from tests conducted by a test facility accredited to ISO 17025, and is issued by that same facility.
2. A verification report is issued by a verifier approved by TCO Development and includes a summary and a result (pass or fail) based on either:
 - a test report issued by the same test facility,
 - a test report issued by a different test facility, or
 - certificates or other proof from the company or brand owner applying for the certificate.

Editions of TCO Certified

When we publish a new generation of TCO Certified, our ambition is always to maintain criteria levels until the next generation of TCO Certified is launched, which typically happens after three years. Several editions of the criteria document may be released, but will be considered only as updates within the ninth generation, with improved precision of the mandates, test methods and clarifications. To ensure that all currently certified products comply with the new edition of the criteria document, the criteria levels are never raised within a generation.

Table of contents

1 Product and sustainability information	8
1.1 Information to end users	9
1.1.1 Mandate	9
1.1.2 Clarification	10
1.2 Product specification	13
1.2.1 Mandate	13
1.2.2 Clarification	14
1.3 Unique product identifier	15
1.3.1 Mandate	15
1.3.2 Clarification	16
2 Socially responsible manufacturing	19
2.1 Supply chain responsibility	22
2.1.1 Mandate	22
2.1.2 Clarification	24
2.2 Supply chain transparency	34
2.2.1 Mandate	34
2.2.2 Clarifications	35
2.3 Anti-bribery management system	37
2.3.1 Mandate	37
2.3.2 Clarification	38
2.4 Responsible mineral sourcing	39
2.4.1 Mandate	39
2.4.2 Clarifications	40
2.5 Process chemicals management	43
2.5.1 Mandate	43
2.5.2 Clarification	44
3 Environmentally responsible manufacturing	46
3.1 Environmental management system	47
3.1.1 Mandate	47
3.1.2 Clarification	48
3.2 Renewable energy	49
3.2.1 Mandate	49
3.2.2 Clarification	50
3.3 Energy management system	54
3.3.1 Mandate	54
3.3.2 Clarification	54
3.4 Post-consumer recycled content	55
3.4.1 Mandate	55
3.4.2 Clarification	56

3.5 Annualized PCF with scope 3 reductions	57
3.5.1 Mandate	57
3.5.2 Clarification	58
4 User health and safety	60
4.1 Electrical safety	61
4.1.1 Mandate	61
4.1.2 Clarification	61
5 Product performance	62
5.1 Energy efficiency	63
5.1.1 Mandate	63
5.1.2 Clarification	63
5.2 Display resolution	66
5.2.1 Mandate	66
5.2.2 Clarification	67
5.3 Correlated color temperature	68
5.3.1 Mandate	68
5.3.2 Clarification	69
5.4 Color gamut	71
5.4.1 Mandate	71
5.4.2 Clarification	72
5.5 Color uniformity	74
5.5.1 Mandate	74
5.5.2 Clarification	75
5.6 Color uniformity – angular dependence	77
5.6.1 Mandate	77
5.6.2 Clarification	78
5.7 Color grayscale linearity	81
5.7.1 Mandate	81
5.7.2 Clarification	82
5.8 Luminance level	84
5.8.1 Mandate	84
5.8.2 Clarification	85
5.9 Luminance uniformity	87
5.9.1 Mandate	87
5.9.2 Clarification	87
5.10 Luminance uniformity - angular-dependence	90
5.10.1 Mandate	90
5.10.2 Clarification	90
5.11 Luminance contrast – characters	95
5.11.1 Mandate	95
5.11.2 Clarification	96
5.12 Luminance contrast – angular dependence	99
5.12.1 Mandate	99

5.12.2 Clarification	100
6 Product lifetime extension	101
6.1 Product warranty	102
6.1.1 Mandate	102
6.1.2 Clarification	103
6.2 Replaceable components	104
6.2.1 Mandate	104
6.2.2 Clarification	105
6.3 Standardized connectors	108
6.3.1 Mandate	108
6.3.2 Clarification	108
6.4 Product durability	109
6.4.1 Mandate	109
6.4.2 Clarification	110
6.5 Battery longevity	111
6.5.1 Mandate	111
6.5.2 Clarifications	111
6.6 Battery replaceability	113
6.6.1 Mandate	113
6.6.2 Clarifications	114
6.7 Battery information and protection	115
6.7.1 Mandate	115
6.7.2 Clarification	116
6.8 Secure data removal	117
6.8.1 Mandate	117
6.8.2 Clarification	118
6.9 Standardized external power supply compatibility	119
6.9.1 Mandate	119
6.9.2 Clarification	119
6.10 Repairability index	120
6.10.1 Mandate	120
6.10.2 Clarifications	120
6.11 Security and functionality software updates	126
6.11.1 Mandate	126
6.11.2 Clarification	127
7 Reduction of hazardous substances	128
7.1 Heavy metals	129
7.1.1 Mandate	129
7.1.2 Clarification	130
7.2 Halogens	131
7.2.1 Mandate	132
7.2.2 Clarification	132
7.3 Non-halogenated substances	134

7.3.1 Mandate	135
7.3.2 Clarification	135
7.4 Plasticizers	138
7.4.1 Mandate	139
7.4.2 Clarification	139
7.5 Hazardous substances in product packaging	141
7.5.1 Mandate	141
7.5.2 Clarification	141
8 Material recovery	142
8.1 Product packaging	143
8.1.1 Mandate	143
8.1.2 Clarification	144
8.2 E-waste management	145
8.2.1 Mandate	145
8.2.2 Clarification	146
9 Test conditions for tablets	148
9.1 General test conditions	148
9.1.1 Definition of a test object	148
9.1.2 Required information about the product	148
9.1.3 Product alignment for testing	148
9.1.4 Settings of the tablet computer	148
9.1.5 Test image/test character	149
9.1.6 Test image and test luminance setting	149
9.1.7 Instruments used for testing	151
9.1.8 Test report	151
9.1.9 Overall uncertainty	151
9.2 Visual ergonomics	152
9.2.1 General test requirements	152
9.2.2 Photometric test facility general requirements	152
9.2.3 Power supply and test room climate requirements for testing	152
9.2.4 Photometric and spectrometric measurements	152
9.2.5 Measurement distance	153
9.2.6 Stray light	153

1 Product and sustainability information

- The IT industry is complex and finding reliable data about products and manufacturing conditions can be a challenge.
- The lack of verified product claims can lead to unfair competition between brands, as well as greenwash.
- Accurate and comparable information helps both brands and purchasers make informed decisions and measure their sustainability progress.

Transparency improves decision-making

To drive sustainable development in the complex IT industry, accurate and comparable information about products and manufacturing conditions is needed. Transparency around this type of data also helps purchasing organizations make more informed product choices, and measure and report the true sustainability impact of the certified models they actually buy. Another positive effect of giving purchasers and industry access to verified product claims is that it helps IT brands compare their sustainability performance with peers, and reduces the risk of unfair competition and greenwash.

Our approach: providing access to independently verified sustainability data

To improve transparency around certified products, and to make it possible to measure and report on the sustainability impact of IT products, data is collected. To ensure accurate reporting, gathered data is verified by independent experts. In cases where the collected data may be made available in a non-anonymous format with purchasers or other stakeholders, it is clearly stated in the criterion mandate under the headline “The following is submitted to TCO Development and may be published”. This data may be published on its own, as a percentage or in combination with other parameters.

Criteria in chapter 1 focus on:

- Improving product identification of certified product models.
- Helping end users find information about TCO Certified, and what the certification includes.
- Making sure that the product specification of certified products is correct.
- Promoting and facilitating the standardization and creation of digital product passports.

1.1 Information to end users

Background

End users must clearly be able to identify which products are certified and what sustainability features the product fulfills.

Applicability

All product categories.

1.1.1 Mandate

The brand owner must fulfill the following (A-D):

- A. The information document to end users must be written in English or in the local language of the country where the product is to be sold and must be distributed to the end user.
- B. The product must be labeled with the TCO Certified logo.
- C. The retail packaging must be labeled with the TCO Certified logo.
- D. "TCO Certified" must be mentioned on the brand owner's website(s) where the specific certified product is marketed and or sold.

Submit the following to an approved verifier:

Necessary documentation describing and proving how:

- The information document to end users is distributed to the end user.
- The product is labeled with the TCO Certified logo.
- The packaging is labeled with the TCO Certified logo.
- TCO Certified is mentioned on the brand owner's website.

The following is submitted to TCO Development:

A copy of the verification report(s) from a verifier approved by TCO Development.

1.1.2 Clarification

The TCO Certified Edge logo may be used as an alternative to the TCO Certified logo if the product has a valid TCO Certified Edge certificate.

The TCO Certified logo must at all times be reproduced in a quality that allows the text of the TCO Certified logo to be read under normal circumstances. The TCO Certified logo must only be reproduced using the designs, colors and resolutions as shown by the originals published and available for download on tco certified.com/industry/logos-and-images/

1.1.1 A - information document for end users

The verifier must be provided with pictures proving how “The information document to end users” accompanies the product in at least one of the following ways:

1. Included in a printed or digital user manual.
2. As a separate digital document or a link to the digital document (<https://tco certified.com/your-product/>) on the brand owner product page that is redirected to when scanning the data carrier as specified in criterion *1.3 Unique product identifier*.

If the information document to end users is included as a link or page in the user manual, it must be found in a separate chapter with the headlined “TCO Certified” that is visible in the table of contents.

No editorial changes to the information document for end users are accepted without consent from TCO Development. The information document for end users is available at tco certified.com.

1.1.1 B - labeling of the product

The verifier must be provided with pictures proving how the product is physically or electronically labeled with the TCO Certified logo in one of the four following ways:

Alternative 1

Physical labeling, logo on product:

The TCO Certified logo may be placed on the product with a permanent or temporary label. A temporary label must be affixed to the product with an adhesive or cling-type application. The label may not be affixed to protective materials that are supposed to be removed in order to get the full functionality of the product.

The logo must be visible on the top or front of the product. (The front of the product is defined as the surface seen when viewing the product from the front and may include the stand. The top is defined as the surface that is seen from the top and the back is the surface that is seen from the back.) If the top and front of the product don't have a contiguous and coplanar area (areas used for display or touch input are excluded) that is at least 16mm in width or 10mm in height, then the logo may be placed on any external part of the product with such surface.

- The minimum size of the logo is 16mm in width and 10mm in height.

- If the logo is to be placed alongside other logos or graphic elements, a minimum of 2,5mm padding must be used on all sides of the TCO Certified logo.

Alternative 2

Physical labeling, data carrier:

A physically affixed barcode that contains the following on the page that is redirected to when scanning the data carrier as specified in criterion 1.3 Unique product identifier without further clicks or scrolling.

- Full name of the certification, including generation
- A link to <https://tcocertified.com/your-product/>
- An image of the TCO Certified logo

Alternative 3

Electronic labeling during the startup of the product:

The TCO Certified logo must cover at least 1% of the screen. The logo must be legible and be in color, black, or white; must appear at system start-up, and must be displayed for a minimum of 0,5 seconds.

Alternative 4

Electronic labeling, via a shortcut on the desktop screen of the product or pinned to the start menu:

The shortcut must be in the form of the TCO Certified logo in color, and clicking it should link to “the information document for end users,” which is available at tcocertified.com.

TCO Development will consider alternative proposals for electronic labeling on a case-by-case basis.

1.1.1 C - Labeling of the product packaging

The verifier must be provided with images showing where the retail packaging of the product will be labeled with the TCO Certified logo.

- The minimum size of the logo must be 16mm in width and 10mm in height.
- If the logo is to be placed alongside other logos or graphic elements, a minimum of 2,5mm padding must be used on all sides of the TCO Certified logo.

The TCO Certified logo is not required on bulk packaging.

Packaging solutions that contain more than one individual product are considered bulk packaging solutions.

1.1.1 D - Mention of TCO Certified on the brand owner's website where the specific certified product is marketed and or sold.

The verifier must be provided with images proving where TCO Certified will be mentioned on the brand owner's website.

- The inclusion of "TCO Certified" only needs to be represented as TEXT - i.e. a link to a specific page is not necessary.
- Instead of mentioning "TCO Certified" directly on the brand owner's website(s), the brand owner can fulfill this requirement by including "TCO Certified" as TEXT in a product-specific PDF file if it is accessible from the brand owner's website(s) where the specific certified product is marketed and or sold.

To fulfill this mandate, the brand owner must submit a description of where and how the inclusion of "TCO Certified" as TEXT can be found for certified products. The description must include a general example of where the TEXT "TCO Certified" will be represented. The description must be submitted to the verification organization. If the location where TCO Certified will be mentioned as TEXT is changed, a new description must be submitted.

Products designed to be installed in a rack (a supporting framework to hold hardware modules, typically servers, data storage products and networking equipment) are excluded from 1.1.1 B and 1.1.1 C.

References

The license agreement between TCO Development and the applicant/brand owner.

1.2 Product specification

Background

It is important to ensure that each product to be certified is described accurately in the test report and certificate. Therefore, a physical sample of each product to be certified must be sent to an approved verifier, that examines it carefully to ensure that product marking and physical aspects conform with the reported information from the applicant or brand owner.

Product weight is an indication of the amount of potential e-waste at end-of-life. By decreasing the product weight, e-waste can be reduced.

Definition

The marking label is a label with the product's electrical rating (voltage, frequency, current), the manufacturer's name, trademark or identification mark, and the manufacturer's model or type reference according to IEC 62368-1 clause 4.1.15.

Applicability

All product categories.

1.2.1 Mandate

- The certified product must be clearly defined through a detailed product specification.
- The total weight of the heaviest product configuration, including the power supply and cables (without packaging) in kg must be reported.

Submit the following to an approved verifier:

- A copy of the marking label, for the product and all external power supplies.
- A product specification to identify the certified product is reported in TCO Certified Portal.

The following is submitted to TCO Development:

- A copy of the verification report(s) from a verifier approved by TCO Development.

The following is submitted to TCO Development and may be published:

- The product specification to identify the certified product is completed in TCO Certified Portal.
-

1.2.2 Clarification

The best case configuration (the lowest total weight configuration) may be added to provide a range for the weight of available configurations. Doing so is optional.

Worst case configuration

There might be several configurations of a product covered by the same certificate. It is necessary that the verification of compliance cover all these configurations. Therefore, the independent verifier must determine the most likely worst-case configuration for compliance with each criterion in TCO Certified. This configuration must be specified in the test reports under each criterion where worst-case configuration is used.

The worst-case configuration must be available for purchase. It must be defined through a unique brand owner code, a unique product identifier, or a list of configuration choices that are available at the time of purchase. *If there are several versions of the same component (e.g. due to different suppliers) and the buyer cannot influence which version they get, then the worst-case version of the component must be reported.)*

References

1. IEC62368-1 Audio/video, information and communication technology, Part 1 -Safety requirements

1.3 Unique product identifier

Background

The criteria ensure that certified products can be sufficiently identified as more sustainable products in the marketplace and throughout the product life cycle. The data carrier should create a communication channel between the brand and the end user and facilitate product lifetime extension, for example, through offering the purchase of warranty extensions, ordering spare parts, or even facilitating reverse supply chains and take-back schemes.

Applicability

All product categories.

Definitions

GTIN: Global Trade Item Number

GIAI: Global Individual Asset Identifier

Unique product identifier: A unique string of characters for the identification of products that also enables a web link to the digital product passport.

Data carrier: a two-dimensional symbol or other automatic identification data capture medium that can be read by a device such as a QR-code or a Data matrix.

Serial number: Any alphanumeric string that functions as a persistent and unique identifier for an individual item.

Date of end of placement on the market: The last manufacturing date.

Build-to-stock: Configurations of a product that have been pre-defined before an order for the configuration have been placed by a customer. These are not linked to a specific order but rather based on sales projections or anticipated customer demand. In this criteria the term build-to-stock is considered to be interchangeable with make-to-stock, Pre-Built, ready-to-ship.

1.3.1 Mandate

Part 1: Global Trade Item Numbers (GTIN) must be submitted for all certified build-to-stock configurations and all certified products sold by others than the brand owner.

Part 2: The product must be marked with a data carrier containing a URL-based unique product identifier.

Part 3: Scanning the data carrier with a smartphone must redirect to a website displaying at least the following product information: GTIN, Model name and Serial number, (without the need to provide additional information).

Submit the following to an approved verifier:

- Documentation showing how the product will be marked.
- Sample URL as encoded in the data carrier
- Sample URL for the destination website, displaying item-specific product information.

The following is submitted to TCO Development:

- A copy of the verification report(s) from a verifier approved by TCO Development.

- GTINs assigned for the product, using the UPI template

The following is submitted to TCO Development and may be published:

- The GTINs assigned with the product.

1.3.2 Clarification

Clarifications for Part 1: Identification of the certified product before purchase

GTIN Submissions

For build-to-stock configurations, it is required to submit GTINs for all configurations no more than 3 months after the certification date. Use the UPI template to submit a list containing all GTIN numbers for the product model. If more GTINs are created after the initial GTIN submission, they need to be submitted in the TCO Certified Portal.

GTINs must be provided for:

- All certified products sold by parties other than the brand owner, whether build-to-stock or configured-to-order.
- All certified build-to-stock products sold by the brand owner.

It is not necessary to create or submit GTINs for configure-to-order products sold exclusively by the brand owner.

Clarifications for Part 2:

Unique product identifier

The URL- based product identity encoded into the data carrier must be able to identify the product on the unit level. This means that it must at least contain the product serial number (any alphanumeric string that functions as a persistent and unique identifier for an individual item).

Examples of Unique product identifiers

All the examples below are compliant but it is recommended to implement a solution according to an example with as low a number as possible. (Example 1 = best practice, Example 3 = least recommended). Example 1 is the direction for this criterion in coming generations of TCO Certified and likely other relevant standards currently under development.

Example 1: Standardized full product identifier (recommended)

URL: <https://www.exampledoimain.com/01/GTIN/21/serial number>

The brand uses GTIN, model name, (GIAI or own) serial number in offline data carriers.

Example 2: Standardized serial number in a GS1 digital link URI syntax URL

URL: <https://www.exampledoimain.com/8004/GIAI>

The brand uses the GS1 identifier (GIAI) Global individual asset identifier using the GS1 digital link URI syntax.

Example 3: Brand owner serial number in non-standardized URL.

URL: <https://www.exampledoimain.com/support /productid?sn=brandowner serial number>

The brand uses its own non-standardized serial numbers and its own URL syntax.

Accepted types of data carriers

QR code or data matrix.

Data carrier quality

The data carrier must be of sufficient quality so that it can be scanned using a smartphone camera indoors under normal lighting conditions. To ensure acceptable data carrier quality, it is recommended to follow ISO/IEC 18004:2015 if the data carrier is a QR-code and ISO/IEC 16022:2006 if the data carrier is a data matrix.

Data carrier placement

Product Category	Data carrier placement
Displays, All-in-one PCs, Desktops	The data carrier must be placed on the outer casing or on the marking plate of the product. It is not allowed to place the data carrier on the bottom side of the product.
Notebooks, Projectors	The data carrier must be placed on the outer casing or on the marking plate of the product
Tablets, Smartphones	Outer casing, or Link in the operating system leading to a website showing unit-specific product information. For example, in the settings menu.
Headsets, Servers, Network equipment, Data storage, General	No mandatory data carrier - serial number only required

Products made up of multiple detachable parts

The data carrier should be attached to at least one of the parts. Such as true wireless earbuds with a charging case, or a tablet shipped with a detachable keyboard.

Data carrier size

It is recommended to use Section 5.12.3 GS1 symbol specification in GS1 General Specifications as a guide to select an appropriate label size to encode the required information.

Clarifications for Part 3:

Website that is redirected to

The URL encoded into the data carrier needs to redirect to a website displaying the product: GTIN, Model name, Serial number, without filling in any additional information.

In the case that no GTIN is created for a configure-to-order configuration, then the following must be presented on the website with unit specific product information instead of the GTIN number:

- A list of selected configuration choices.
- Mention that the product is certified according to TCO Certified.

Initial implementation period of the website

The first time a brand applies for a TCO Certified Generation 10 certificate, an initial implementation period of 12 months may be granted to implement functionality so that the scanning of the data carrier leads to a website displaying product information on the item level. Contact TCO Development if you need this extra time.

During this period the scanning of the data carrier can lead to any website that the brandowner finds suitable, for example the product page.

Duration of availability

The brand owner must publicly guarantee the availability of a website displaying the required information for at least 5 years after the end of placement on the market (which is defined as the last manufacturing date).

Language selection

It is allowed to have a language selection pop-up. If a language selection is presented, a maximum of two subdirectories is allowed to be changed in the URL after a language has been selected. One for language, and one for region.

See the underlined text in the examples below:

One subdirectory:

[https://support.brand.com/us-en/product/model-123-abc-notebook-pc/123456789](https://support.brand.com/<u>us-en</u>/product/model-123-abc-notebook-pc/123456789)

Two subdirectories:

[https://support.brand.com/us/en/product/model-123-abc-notebook-pc/123456789](https://support.brand.com/<u>us</u>/<u>en</u>/product/model-123-abc-notebook-pc/123456789)

Accepted places on the page to display the required product information

The required product information needs to be visible directly when the page is loaded or in an expandable section or tab of the page that adheres to the following:

- The name of the tab/section clearly describes that clicking it will display the required data.
- Only one click is required to access the required data.
- The URL is not changed when clicking the tab.

2 Socially responsible manufacturing

- Poor working conditions are common throughout the IT product supply chain.
- Child labor, forced labor, excessive overtime and hazardous substances are risks to workers' health and lives.
- To drive social responsibility, a structured system for continuous improvements is needed, along with strict monitoring to ensure problems are resolved.

Social risk is present throughout the supply chain

Much of IT product manufacturing is carried out in low-wage countries where the labor market lacks clear regulation, and the protection of workers is insufficient. Poor working conditions occur throughout the supply chain. Sustainability risks include child labor, forced labor, and hazardous chemicals used in manufacturing. Excessive overtime leaves a worker with little to no time over for rest, recreation, family or further education. The mineral industry is connected to armed conflicts and human rights abuses, severe health problems for workers, and environmental degradation. As in many industries, the risk of bribery is also present. This must be counteracted as it hinders development, erodes justice, undermines human rights and interferes with the fair and efficient operation of markets.

Our approach: driving worker safety, human rights and closing non-conformities

Driving social responsibility throughout the complex IT product supply chain requires a clear and systematic approach. TCO Certified includes a framework that encourages proactive work and helps brand owners structure their work with sustainability. Corrective action plans must be developed and implemented within a set timeframe. To drive change where it's needed the most, monitoring of high-risk factories is intensified.

Criteria in chapter 2 focus on:

- Ensuring safer working conditions by requiring that the code of conduct is implemented throughout the supply chain.
- Guiding the industry to more sustainable practices with a structured system for continuous improvement.
- Requiring transparency about which suppliers are being used to increase accountability.
- Taking the next step in combating corruption in the supply chain by requiring compliance with the more ambitious anti-bribery standard ISO 37001.
- Continuing independent verification of due diligence all the way to the source of the minerals, to ensure that minerals are sourced responsibly.
- Requiring that all cleaning process chemicals are assessed by an independent toxicologist and benchmarked as a safer alternative before being used in the manufacture of certified products. The same principle applies also to chemicals added to the product, covered in chapter 7.

Definitions

3TG: tin, tungsten, tantalum, gold.

Anti-bribery management system: A system designed to help organizations instill an anti-bribery culture and implement appropriate controls to detect and address bribery.

Brand owner: The company or organization owning or controlling the brand name of the product.

Bribery: Giving or receiving an unearned reward to influence someone's behavior.

Business licence: A business licence covers an independent work unit, which means it has its own separate production areas, operation and management system, including but not limited to recruitment, working hours system, wage and benefit system, factory rules, etc. and all employees that under contract are dedicated to that factory.

Cleaning solvents: Chemicals and chemical mixtures used to remove contaminants, unwanted materials, and/or manufacture process residues (e.g. lubricants, adhesives, solder flux residues, plastic residue, and mold releases). Examples of process chemicals used for cleaning include: solvents, aqueous detergent solutions, stencil/ink removers, adhesive removers, solvent vapor degreaser solutions, ultrasonic parts cleaner solutions, photo-resist strippers, and solder-defluxing solutions.

Conflict-affected and high-risk areas: Areas in a state of armed conflict, fragile post-conflict areas, and areas witnessing weak or non-existing governance and security, such as failed states. In these areas, there are often widespread and systematic violations of international law, including human rights abuses.

Corrective action plan (CAP): A list of actions the brand owner is responsible for implementing within a set timeframe to address a specific problem.

Corruption: Gaining an advantage through illegitimate means. Bribery, abuse of power, extortion, fraud, deception, collusion, cartels, embezzlement and money laundering are all forms of corruption.

CPA: Clean Production Action. Developers of GreenScreen® for Safer Chemicals.

Final assembly factory: A final assembly factory is where the final assembly of the certified product takes place and is defined as the whole operation covered by a business license. If the final assembly of the product is divided over more than one factory, all are considered final assembly factories.

Licensed GreenScreen Profilers: Toxicology firms licensed by CPA to provide GreenScreen assessment services for a fee to clients.

Next-tier suppliers: Suppliers to the final assembly factory of parts and packing materials for the certified product.

Panel manufacturer: The panel manufacturer is defined as the place where the final assembly of the panel takes place.

Process chemical inventory: A record the factory keeps showing the process chemicals used to manufacture certified products.

Process chemicals: Chemicals (individual chemicals or mixtures) used during the manufacture of a product and/or to maintain related production equipment. Process chemicals are not intentionally fully incorporated into the product. Cleaning agents, lubricants and additives are examples of process chemicals.

Refining: A process that increases the grade or purity of a metal.

Responsible Minerals Assurance Process (RMAP): Independent third-party assessment of smelter and refiner management systems and sourcing practices to validate conformance with RMAP standards.

Responsible minerals initiative (RMI): Member initiative for implementing minerals supply chain due diligence.

Smelting: The process of applying heat to ore in order to extract a base metal.

SMT: Surface-mount technology is a method in which the electrical components are mounted directly onto the surface of a printed circuit board (PCB). An electrical component mounted in this manner is called a surface-mount device (SMD).

2.1 Supply chain responsibility

Background

Social responsibility is a continuing challenge throughout the IT supply chain. From raw materials extraction to final assembly, working hours, health and safety and forced labor are examples of industry-wide issues. However, for those who want to drive greater social responsibility, a major issue is the complexity of the IT product supply chain. It includes many suppliers that are spread all over the world.

The most basic aspect of social responsibility in the supply chains is to define who holds the responsibility. After this is done, the level of conformity and the implementation in the supply chains need to be defined. Finally, to make sure that problems are solved and improvements are made, independent verification and follow-up is crucial. Continued monitoring is essential, even after closure. TCO Certified offers a structured platform to guide industry progress:

- The responsibility for correcting non-conformities is placed on the brand owner, which is at the top of the product value chain.
- Define minimum standards of the brand owner code of conduct covering the manufacturing of the certified product.
- We provide a control system to ensure that the brand owner takes responsibility in the supply chains of the certified product and works in a structured way in accordance with the code of conduct.
- By including a system of consequences for continued non-conformities, we incentivise the brand owner to work proactively.

Applicability

All product categories.

2.1.1 Mandate

By signing this mandate, the brand owner agrees to (1.) the Commitment and agrees to conduct (2) the Structured work. Additionally, TCO Development requires that the brand owner shows (3) Proof of the commitment and the structured work by allowing inspections in the supply chains of the certified product, sharing audit reports and CAPs, and providing other documented proof described below.

1. Commitment

- The brand owner must have a public code of conduct for the manufacture of certified products considered consistent with the following principles and rights at work:
 - ILO's fundamental conventions: 29, 87*, 98*, 100, 105, 111, 138, 155, 182 and 187.
 - The UN Convention on the Rights of the Child, Article 32.
 - All applicable local and national health and safety and labor laws effective in the country of manufacture, and a maximum 60-hour workweek including overtime*.

*See clarifications 1 and 2

2. Structured work

- The brand owner must register each final assembly factory and each factory manufacturing display panels >10" for the product model(s) that the application covers to TCO Certified Portal and supervise the implementation of the code of conduct at these factories.
- The brand owner must ensure all registered factories have identified and communicated the code of conduct to their next tier suppliers of parts for certified products.

3. Proof

- The brand owner code of conduct and communication process must be annually verified during the annual review process.
- Accepted initial audit reports, closure audit reports and corrective action plans for each registered factory must be uploaded to TCO Certified Portal.
- The supply chain identification template (SCIT) must be submitted. The template must be uploaded to TCO Certified Portal for only the registered final assembly factory. An updated SCIT may be required to be resubmitted at any time.
Data on the following suppliers for the following parts must be included in the SCIT:
 - Product housing: Enclosure (chassis) including stand: Parts >0.5 grams.
 - Printed circuit board supplied with and without components attached: Mainboard (motherboard) and power board.
 - External cables: Power and peripheral connecting cables.
 - Processors and memory: CPU, GPU, chipset, DRAM, RAM, SSD and HDD.
 - Battery: Remote power source of the product.
 - Power supplies: internal and external.
 - Display panel (all sizes).
- TCO Development may also require seeing audit reports and corrective action plans from factories further up the supply chains of the certified product to ensure that corrective actions have been successfully implemented.
- TCO Development additionally requires that supporting documentation be verified by an independent verifier approved by TCO Development.
- TCO Development may commission random factory audits (spot checks) at any factories registered to TCO Certified Portal.

Submit the following to an approved verifier:

Once a year at the Senior Management Representative annual review:

- The brand owner's public code of conduct communicated to the supply chains of the certified product. The code of conduct must be considered consistent with this mandate.
- Supporting Information on the routines of how management and workers in each registered factory are informed about the code of conduct.

For each application:

- A copy of the factory list in the CB certificate with the names and addresses of all final assembly factories manufacturing the certified product model. If any of these factories are not registered to TCO Certified Accepted Factory List, the brand owner must submit the factory identification template to register the factory or prove that the factory is not manufacturing the certified product model.

- Name and address of each factory where the display panel is manufactured for the certified model. This includes a clarification of the manufacturer ID on the panel marking label. The name and addresses must be registered to TCO Certified Accepted Factory List using the factory identification template.
- Check that the brand name is listed as compliant without missed due dates on TCO Certified Portal. Any missed due dates will mean a certification application cannot proceed until the required documentation is submitted and the due date is extended or marked compliant.

For each final assembly factory and factory manufacturing display panels >10" for the certified product:

- The most recent independent initial audit report, corrective action plan for each non-conformity and closure audit report must be uploaded to TCO Certified Portal. The audit interval is determined by the risk category of the factory. The risk category is set by the verifier according to the process described under: **Audit report and factory risk categorization.**
- The supply chain identification template (SCIT) must be completed and submitted to TCO Certified Portal for each registered final assembly factory.

The following is submitted to TCO Development:

- A copy of a verification report from a verifier approved by TCO Development.
- A copy of an English version of the public code of conduct must be uploaded to TCO Certified Portal.
- An independent audit and a corrective action plan for each non-conformity must be reported to TCO Certified Portal at an interval determined by the risk category of the registered factory for the certified product.

The following is submitted to TCO Development and may be published:

- The status (YES/NO), if all factories manufacturing the certified products are category 3, is automatically collected.

2.1.2 Clarification

General clarifications

The mandate is a social performance mandate, and criteria are based on ILO's (International Labour Organization) fundamental conventions and local legislation. The mandate requires that the brand owner comply with the minimum standards for code of conduct, inspection and corrective action engagement regarding the supply chain of the certified product.

* Convention 87 and 98: Collective bargaining and freedom of association: All workers must have the right to form, join and organize trade unions of their choice and to have them bargain collectively on their behalf with employers. In situations where this is restricted under law, employers must allow workers to freely and democratically elect their own representative(s) for the purpose of defending the rights and interests of workers.

* Local labor law: The limit and enforcement of local law regarding working hours differ tremendously globally. To harmonize with other initiatives and to find a reasonable level for

the industry, the criteria in TCO Certified sets a maximum 60 hour workweek, including overtime, as a global requirement regardless of the local law.

* 60 hour working week: This criterion sets a global limit for weekly working hours that includes overtime based on ILO convention 1 (56 hours per work week including overtime). An additional four hours per workweek is given to harmonize with SAI and RBA. Therefore, workweeks, including overtime, are not to exceed 60 hours, and workers must receive at least 1 day off every 7 consecutive days.

TCO Certified has established thresholds for non-compliance with working hours. For factories up to 15000 employees, the following is applicable;

- Minor non-compliance: up to 2% of the total workforce working between 60 and 72 hours per week
- Major non-compliance: 2% - 15% of the total workforce working between 60 and 72 hours per week
- Priority non-compliance: More than 15% of the total workforce working between 60 and 72 hours per week or any percentage of the workforce working above 72 hours per week.

The verification process

Proof documentation must be submitted to an independent verifier approved by TCO Development. It is the verifier's responsibility to request any additional documents necessary for the review. The verifier will evaluate the information received from the brand owner according to the principles described below (1-5).

1. The code of conduct:

The brand owner must have their code of conduct covering the supply chains of the certified product reviewed annually by an approved verifier. If the code of conduct has not changed since the previous annual review, the brand owner does not have to submit it again. The Senior Management Representative (SMR) for supply chain responsibility must report this to an approved verifier. The approved verifier carries out the verification during the annual review process.

- The code of conduct must be consistent with all parts under **1. Commitment.**
- The contents of the code of conduct must have been adopted by the brand owner's board and addressed by management.
- The code of conduct must cover the manufacturing of the certified product.

2. Information about the code of conduct:

The brand owner must annually submit a description of how management and workers at all registered factories manufacturing certified products are informed about all parts of the code of conduct. Proof of training classes or other means of worker training and how the factory measures the effectiveness of the worker training must be submitted for review. The training must be held specifically for the purpose of training and not just part of a regular business review meeting. If there are no changes to the communication routine since the previous annual review, then the brand owner does not have to submit it again. In this instance, the

SMR must report this to an approved verifier. The approved verifier carries out the verification during the annual review process.

Accepted proof of compliance. All parts must be fulfilled:

- Training on all parts of the code of conduct for management and workers or worker representatives at registered factories of the certified product.
- Training is through workshops, e-learning, or online training programs.
- There is a questionnaire (self-assessment) process to assess management and worker understanding and conformity with the code of conduct.

3. Factory registration on TCO Certified Portal

For each certified product, each final assembly factory and each factory manufacturing display panels >10" for the certified product must be identified and registered to TCO Certified Portal.

The approved verifier will ensure that factories are listed on TCO Certified Accepted Factory List.

- Factories are registered to TCO Certified Portal Accepted Factory List using the factory identification template.
- The SCIT must be submitted for each final assembly factory for the certified product. It is not necessary to submit a SCIT for the display panel factories.
- The full list of factories must be submitted at least once annually to an accepted verifier using the factory identification template. The due date for submitting the template appears on TCO Certified Portal. An approved verifier must be notified immediately of factory changes. The template is downloaded from tcocertified.com.

4. Independent social audit reports

The brand owner must ensure that TCO Certified Portal is continuously updated with the most recent independent initial audit report and corrective action plans for all non-conformities found during the audit from all registered factories manufacturing the certified product.

Brand owners or applicants/manufacturers must submit audit reports and corrective action plans to an approved verifier for upload to TCO Certified Portal.

Factory audit intervals are determined by the risk category of the factory.

1. Independent audits must be conducted by organizations accredited to ISO 17021 and carried out by SA8000 or RBA lead auditors who are APSCA certified. The lead auditor's APSCA membership number must appear in the audit report.
2. Accepted audits:
 - a. SA8000,
 - b. RBA VAP,
 - c. Other audit types, if independently verified to be of equal quality to one of the accepted audits (a or b). This includes auditor qualification, audit process (e.g. triangulation of non-conformities), reporting and CAP. Verification will be conducted by an approved verifier before an alternative audit is accepted as proof.

Defining the factory risk category and audit intervals

A factory new to TCO Certified Portal must be independently audited using an accepted audit type. Any SA8000 certificate or RBA recognition diploma must be submitted with the initial audit report. A factory is assigned a category 1, 2 or 3 based on the risk categorization procedure below.

Brand owners new to TCO Certified or applying for certification to a new product category must undergo a risk assessment. This is for TCO Development to assess the likelihood of fulfilling the requirements within the given time. If the brand owner or factory is considered a higher risk for receiving an extended time (for example: a history of non-compliance), an audit report and a corrective action plan must be submitted before the factory can be registered to TCO Certified Portal.

Lower risk countries

Some countries are considered as lower risk of social non-conformities by the SA8000 Country Risk Assessments Process, which is based on World Governance Indicators (WGI). These countries include but are not limited to: EU countries, USA and Japan. Country risk level is a factor that is considered when setting category levels 2 and 3.

TCO Certified Accepted Factory List

All brand owners, applicants and verifiers who have access to TCO Certified Portal will have access to see TCO Certified Accepted Factory List of registered factories. This list includes information such as the risk category, audit non-conformities and due dates for submitting supporting documentation. Access to information for factories directly owned by a brand owner is limited to that brand owner.

Risk categorization procedure.

Initial audits are required at regular intervals. The audit interval is based on the factory risk category.

- An **initial audit** covers the whole factory and this criterion.
- A **closure audit** covers at least the open non-conformities from the latest initial audit.
- An initial audit is more comprehensive and is accepted as a closure audit.
- Audits older than 12 months are not accepted.

Initial risk categorization

- Risk category 1 is given to all new factories entering TCO Certified Portal, TCO Certified Accepted Factory List. Factories cannot continue as category 1 for more than 18 months or return to category 1 once they have been category 2 or 3.

Risk category 1 (higher risk choice).

Initial audit

- Only risk category 1 factories receive up to 18 months to achieve risk category 2 or 3. Only initial audits less than 12 months old from the date the factory is registered on TCO Certified Portal are accepted. Any priority and major non-conformities to TCO Certified must be independently verified closed with a closure audit within the time period specified in the table below. The due date for achieving category 2 or 3 appears on TCO Certified Portal for each active factory.

Audit status on initial factory registration date	Priority and/or Major non-compliances	Months to achieve category 2 or 3
Without an initial or closure audit.	Unknown	18 months to conduct an initial and closure audit
With an initial audit report less than 6 months old	Yes	12 months to conduct a closure audit
With an initial audit report less than 12 months old	Yes	6 months to conduct a closure audit

Corrective action plan

- For each non-conformity to the mandate commitment, a corrective action plan must be uploaded to TCO Certified Portal. It must include closure deadlines set by the audit program to complete each corrective action.

Closure audit

- If there are major or priority non-conformities in the initial audit, a closure audit must be submitted within the remaining time (see table above). The due date for the closure audit appears on TCO Certified Portal. The corrective action plan must be completed for minor non-conformities, but it is not necessary to submit the closure audit.

Re-categorization

- When all non-conformities other than minor are closed, the factory will be categorized as risk category 2. If the factory is also placed in a lower-risk country or certified according to SA8000, it will be categorized as 3 instead of 2.

Final assistance

- If the factory has been categorized as a risk category 1 for 18 months, then the factory management may receive final assistance toward conformity through TCO Certified Active Monitoring Program. If the brand owner or factory decides not to commit to the program, the factory will be removed from TCO Certified Accepted Factory List, and the factory will no longer be allowed to manufacture products certified to TCO Certified.

Risk category 2 (moderate risk choice).

Initial audit

- For risk category 2, the factory must be audited every 24 months. A new initial audit report must be uploaded to TCO Certified Portal during the 24-month audit period, and all major and priority findings must be independently verified closed within this time. The due date for submitting audit proof to retain a place on TCO Certified Accepted Factory List is shown on TCO Certified Portal.

Corrective action plan

- For each non-conformity to the mandate in TCO Certified, a corrective action plan must be uploaded to TCO Certified Portal. It must include closure deadlines set by the audit program to complete each corrective action.

Closure audit

- If there are major or priority non-conformities, a closure audit must also be uploaded to TCO Certified Portal during the 24-month audit period. If the factory only has minor non-conformities, the corrective action plan must be completed, but it is not necessary to upload the closure audit to TCO Certified Portal. The closure of minor non-conformities will be verified in the next initial audit.

The initial audit should be conducted at least 6 months before the factory audit due date on TCO Certified Portal to give time for a closure audit (if one is necessary).

Failure to retain category 2

- Failure of the factory to retain category 2 within the due date will cause it to be flagged on TCO Certified Portal, which means no certification applications for products manufactured at the factory are approved until the remaining non-compliances are closed. Additional time to close remaining non-compliances may be applied following a risk assessment of the reasons behind the failure to close the non-compliances on time and the closure time plan submitted by the factory. If the brand owner or factory decides not to commit to retaining category 2, the factory will be removed from TCO Certified Accepted Factory List, and the factory will no longer be allowed to manufacture products certified to TCO Certified.

Risk category 3 (lower risk choice).

Initial audit

- For risk category 3, the factory must be audited every 36 months. A new initial audit must be uploaded to the TCO Certified Portal during the 36-month audit period, and all major and priority findings must be independently verified closed within this time. The due date for submitting audit proof to retain a place on TCO Certified Accepted Factory List is shown on TCO Certified Portal.

Corrective action plan

- For each non-conformity to the mandate in TCO Certified, a corrective action plan must be uploaded to TCO Certified Portal. It must include closure deadlines set by the audit program to complete each corrective action.
 - If the factory is SA8000 certified, then the non-conformities are solved following the SA8000 certification procedure.

Closure audit

- If there are major or priority non-conformities, a closure audit must also be uploaded to TCO Certified Portal during the 36-month audit period. If the factory only has minor non-conformities, the corrective action plan must be completed, but uploading the closure audit to TCO Certified Portal is not required. The closure of minor non-conformities will be verified in the next initial audit.
 - A valid SA8000 certificate is considered proof that major and priority non-conformities are monitored regularly by SAAS-accredited verifiers and that issues are being solved.

The initial audit should be conducted at least 6 months before the factory audit due date on TCO Certified Portal to give time for a closure audit (if one is necessary).

Qualification method and assessment of worker-management dialogue

For factories at-risk category 1 it is very likely that the worker-management dialogue is not mature enough due to the number of persistent non-conformities. However, once a factory has managed to solve their major and priority non-conformities and achieved risk category 2, they may apply for risk category 3 re-categorization based on worker-management dialogue. To qualify for re-categorization to risk category 3 all the below verification points for a Trade union or non-union worker representation must be considered compliant without remarks.

Verification of the level of worker/management dialogue at the factory.

In order for a factory to be able to get re-categorization from risk category 2 to 3 based on the worker-management dialogue, the factory management, and worker representatives must together prove the following. The proof must be assessed during the factory audit every 3 years by an independent auditor approved by TCO Development. To become approved the auditor evaluating worker management dialogue must fulfill all the requirements of auditors in TCO Certified and must also have documented experience and deep understanding of trade union work.

In the case of a Trade union (TU)

Criteria for assessing a Trade union (TU) presence at factories in high-risk countries for consideration for TCO Certified risk category 3 status.

Requirements on the trade union

1. The TU is not in any way interfered with or financed by the factory management and is independent from the local and national government.
2. The TU is financed by membership fees or donations from non-profit organisations and is non-profit
3. The TU has bargaining rights and acts on the behalf of employees in collective bargaining negotiations with employers.
4. The TU should set and fulfill some or all of the goals it sets itself to win concessions for workers, such as: improve working conditions, working hours, wages and benefits

Requirements on the management

5. Factory management contributions are limited to providing meeting space/materials
6. Payroll records etc show TU employees are not discriminated if they also work at the factory
7. No management interference with the TU representative meeting new consenting employees to explain their rights to freely join the TU and membership is open to all employees.
8. The TU has the ability to call a strike, without restriction from government or company management.

Requirements on the worker - management dialogue

9. TU meets with management regularly for the purpose of furthering and defending the rights and interests of workers for mutual gains. TU meeting minutes and financial records are kept and made available.
10. TU representatives have access to
 - a. Risk assessments
 - b. Internal audits and monitoring of the organization
 - c. Relevant and appropriate aspects of management review
 - d. Opening and closing meetings of labor audits
 - e. Reporting back to workers on any corrective and preventive actions taken
 - f. Reporting back to Senior Management on the performance and benefits of actions taken to meet the criteria in the audit

In case of a non-union worker representation

If the above union criteria are not possible to fulfill due to country laws restricting freedom of association and collective bargaining, workers shall be allowed to freely elect their own non-union representatives. (Note: worker representation should not be seen as a substitution for a union representative in organizations where workers freely choose to organize.)

An organised committee of democratically elected worker representatives from non-management personnel is defined as a democratic trade union like system and must meet the following criteria:

1. An organised committee consists of democratically elected representatives from non-management personnel and is independent from the local and national government.
2. The number of representatives shall be in proportion to the number of workers at the factory and must be in the range 1 for every 50-100 workers.
3. The worker committee has the right to represent the workers in collective negotiations with management.
4. The committee has set and fulfills some or all of the goals it sets itself to win concessions for workers, such as: improve working conditions, working hours, wages and benefits.

Requirements on the management

5. Management has not intervened or interfered in any way in the nomination, election, operation, administration of the committee.
6. Payroll records etc show worker representatives are not discriminated against if they also work at the factory. Workers representatives must be allowed to carry out their duties in the organized worker committee during normal working hours without any wage deductions.
7. The worker committee is free to fulfill their goals without being subjected to discrimination, harassment, intimidation, or retaliation for being representative(s) of workers or engaged in organizing workers, and that all workers have access to the representatives in the workplace and access to their services.
8. Worker representatives have the possibility to meet all new consenting employees to explain their labor rights.
9. Committee members shall be allowed to attend relevant committee-training during normal working hours without getting wage deductions to help fulfill their duties
10. Factory management must provide meeting space/materials

Requirements on the worker - management dialogue

11. Committee meets with management regularly for the purpose of furthering and defending the rights and interests of workers for mutual gains. Meeting minutes and financial records are kept and made available.
12. The non-union committee have access to
 - a. Risk assessments
 - b. Internal audits and monitoring of the organization
 - c. Relevant and appropriate aspects of management review
 - d. Opening and closing meetings of labor audits, includes RBA and SA8000 audits
 - e. Reporting back to workers on any corrective and preventive actions taken
 - f. Reporting back to Senior Management on the performance and benefits of actions taken to meet the corrective and preventative actions.

Additional clarifications that are valid for all risk categories

- If the audit program and lead auditor accepts an offsite closure audit it will also be accepted in TCO Certified.
- If proven conditions change, such as when non-conformities are found during a spot check, the risk categorization will be re-assessed.
- A major non-compliance given to a control point in the audit report for the only reason that working hours do not meet the stricter local legislated levels than the 60 hour workweek permitted in TCO Certified may have this rating altered to compliance on TCO Certified Portal on condition that the 60 hour working week requirement is met.
- Closure of priority findings within the CAP deadline will be monitored by TCO Development through the spot check program.

On-site factory inspection initiated by TCO Development (spot checks).

TCO Development reserves the right to require full audit reports and conduct or commission on-site inspections at factories registered on TCO Certified Portal as manufacturing the certified product to monitor continued compliance to obligations in this criterion. The planning of social audits will be done in cooperation with the Senior Management Representatives appointed by the brand owner, accepted social auditors and factory management. Factory audits are announced in advance.

Social audits initiated by TCO Development will be realized on a judgment sample basis, in each case decided upon by TCO Development. Audit results will be shared with the audited factory management and all the brand owners listed using the audited factory to combine the effort to close any non-compliance.

Spot check audits are financed by TCO Development. If priority non-conformities are found and further investigations are necessary, the license holder must cover this cost.

The verifier approved for supply chain responsibility

Only an independent verifier approved by TCO Development has the authority to approve the following:

For each brand owner:

- Code of conduct.
- Communication of the code of conduct.
- Supporting documentation.
- Conduct reviews with a senior management representative.

Other assessments

- Review evidence that could prove that another audit protocol can be considered “equal quality to other approved audit protocols”. This includes but is not limited to auditor qualification, audit process, reporting and corrective action plan.

The list of approved verifiers is found at tcocertified.com.

References

1. SA8000, <http://www.sa-intl.org>
2. Responsible Business Alliance (RBA), <http://www.responsiblebusiness.org>

2.2 Supply chain transparency

Background

Supply chain transparency includes two vital parts: a) the extent to which information about a company and its sourcing locations is made public to end-users and stakeholders and b) the company's process of taking action through supply chain visibility to manage it effectively. Companies struggle to achieve supply chain transparency since they lack a solid process and structure to manage risks and monitor behavior in their extended supplier network. Without visibility into their supply chains, brand owners create a blind spot where damage to reputation can emerge.

Transparency toward an independent party provides a company not only with the possibility to measure its own performance in key areas against its peers but also a way to share and gain knowledge about solutions. Supply chain transparency requires a solid management system, where improvements are achieved by acting on responses to shared information.

Applicability

All product categories.

2.2.1 Mandate

The brand owner must appoint a Senior Management Representative (SMR) for supply chain responsibility for the certified product, who reports directly to senior management.

Irrespective of other duties, this person must have the authority to ensure that the certified product meets the supply chain criteria in TCO Certified.

The SMR has access to TCO Certified Portal and must ensure that the due dates for submitting supporting documentation are complied with.

The SMR is responsible for the brand owner annual review process being completed with an approved verifier, and the report is uploaded to TCO Certified Portal before the annual due date.

Submit the following to an approved verifier:

Once a year at the Senior Management Representative interview:

- A completed annual review report including the verified self-assessment questionnaire (SAQ)

TCO Certified portal must have up to date information on:

- Name, title, telephone number and email address of the SMR

The following is submitted to TCO Development:

- The report from the annual review must be uploaded to TCO Certified Portal.
- A copy of a verification report from a verifier approved by TCO Development.

The following is submitted to TCO Development and may be published:

- The status (Yes/No & link to public list), if all final assembly factories manufacturing the certified product are listed publicly by the brand owner.

2.2.2 Clarifications

General clarifications

The aim of the mandate is to create transparency between TCO Development and senior management at the brand owner company of the certified product.

Senior Management Representative (SMR) details

The required details of the SMR must appear in TCO Certified Portal, and the SMR must be available for dialogue in English with TCO Development and verifiers throughout the validity of all the brand owner's certificates.

If the appointed SMR is changed, then details of the new SMR must be updated in TCO Certified Portal. TCO Development must be informed immediately.

The SMR must ensure that TCO Certified Portal is up to date, covering the following:

- Name, title, telephone number and email address of the SMR.
- A valid annual review report.

SMR and annual review

The annual review must be done with one of the verifiers approved by TCO Development. It is booked and paid for by the SMR company. The purpose is to ensure that the appointed person has the necessary authority and that the company works in a structured way to implement the points covered in the annual review questionnaire.

If the brand owner has more than one brand name registered, the review must cover each brand name respectively and ensure that all requirements in TCO Certified are fulfilled. The verifier must ensure that it is intuitive for anyone searching for the required information on each brand name's website where to find the information. In some cases, this means that it must be publicly stated who owns the brand name or that links are provided to the documents on the brand owner's website.

As part of the annual review process, all questions must be answered and submitted to the verifier before the interview. During the part of the review questionnaire that covers the section on social performance, the SMR will be required to explain the brand owner's work toward a socially responsible supply chain of the certified product and provide supporting documentation where needed. It is recommended that SMRs involve colleagues in the meeting who can provide the necessary expertise in the areas covered by the questions. The interview part of the review process will likely be an online meeting. If it is not possible to have an online meeting or the interview does not obtain an acceptable quality due to language difficulties, then the verifier may require a face-to-face interview. TCO Development has the right to participate in the interview with the SMR. In this case, TCO Development will cover its own expenses.

The final report from the annual review is then uploaded to TCO Certified Portal by the verifier. The annual review questionnaire is revised every third year, following the launch of a new generation of TCO Certified.

An evaluation is made based on the review results regarding the voluntary public disclosure of final assembly factories. There is no mandatory level, but this information may be shared with purchasers.

The link to the brand's publicly disclosed factories (if available) is taken from the review results and entered into TCO Certified Portal. After the report is uploaded, the verifier cross-checks the publicly disclosed factories at the provided link against the final assembly factories used by the brand to manufacture certified products in TCO Certified Portal.

To count a final assembly factory as publicly listed, it must be made public on the brand owner website and state that the brand owner has a business relationship with those factories. The factory information must show at least the supplier name, factory full address and type of products manufactured at the factory.

About the annual review questionnaire benchmarking

The annual review questionnaire is an independent assessment of the brand owner's risk management of the supply chain of the certified product and is part of TCO Development's capacity-building work with brand owners.

The SMR is responsible for answering all questions and providing supporting documentation where needed. Answers are verified and the level of achievement is benchmarked by the verifier..

For the annual SMR interview questionnaire is intended to gather information on the actual level of social commitment, identify capacity-building possibilities, share solutions, and assist in developing future generations of TCO-certified criteria. Feedback to the brand owner is given in the form of a report and table showing the brand owner's final grading (after the interview) compared to other certifying brand owners (all brand names are kept anonymous). This helps the brand owner identify areas for improvement and measure their progress within the industry.

Result data will also be used to risk assess factories of the certified product for the spot-check program. In this program, TCO Development orders annual factory audits according to the code of conduct by independent auditors at a number of final assembly factories where certified products are manufactured.

The annual review questionnaire and guidelines for the annual review process are public and available for download at tcocertified.com

2.3 Anti-bribery management system

Background

Bribery is a widespread phenomenon. It raises serious moral, economic and political concerns, undermines good governance, hinders development and distorts competition. It erodes justice, undermines human rights, and hinders poverty relief. It also increases the cost of doing business, introduces uncertainties in commercial transactions, increases the cost of goods and services, diminishes the quality of products and services, which may lead to loss of life and property, destroys trust in institutions and interferes with the fair and efficient operation of markets.

Organizations are responsible for preventing all forms of corruption within their businesses and supply chains. To do so, organizations must align their business policy, monitoring and enforcement mechanisms with internationally recognized best practices against all forms of bribery.

With TCO Certified, brand owners that apply for product certification are reviewed by an independent reviewer, who assesses the brand owner's anti-bribery management system to ensure that it meets the requirements of ISO 37001.

Applicability

All product categories.

2.3.1 Mandate

The brand owner must have internal processes and routines in place to prevent and respond to all forms of bribery, covering all business activities connected to the certified product. This includes ensuring that the supply chain of at least the certified product aligns with the anti-bribery management system standard ISO 37001.

Submit the following to an approved verifier:

- An ISO 37001 certificate or the anti-bribery review report by an approved verifier.

The following is submitted to TCO Development:

- A copy of a verification report from a verifier approved by TCO Development.

2.3.2 Clarification

The brand owner's anti-bribery management system covering all business activities connected to the certified product, including the supply chain, must be considered to be aligned with ISO 37001. If an ISO 37001 certificate is unavailable as proof, the brand owner can complete the questionnaire and take part in a follow-up verification review with an approved verifier.

A follow-up review of the brand owner anti-bribery management system will be in the form of a questionnaire and included in the first annual review with the assigned Senior Management Representative (SMR) for supply chain responsibility.

Each answer to the questionnaire will be graded using: Green is aligned, yellow is partial alignment and red is no alignment. A completed questionnaire and supporting documentation must be submitted to the verifier before the review. These will be verified in the online review between the verifier and the brand owner SMR and any experts responsible for anti-bribery the SMR wishes to include.

Verification guidelines

- Alignment to ISO 37001 without providing a valid certificate is when all answers are scored green (except 12.1) in the anti-bribery section of the annual review questionnaire. When all required points are aligned, there is no need to include anti-bribery in the following annual reviews unless requested by TCO Development.
- If any point (except 12.1) is scored yellow or red, a corrective action plan must be made, and the point will be included in the following annual review and must be scored green.
- Only question 12.1 (covering independent verification of the anti-bribery management system) can be graded yellow or red since this review in TCO Certified is considered an independent verification of the anti-bribery management system.

References

1. <https://www.iso.org/iso-37001-anti-bribery-management.html>

2.4 Responsible mineral sourcing

Background

Minerals such as tin, tantalum, tungsten, gold and cobalt are connected to armed conflicts and human rights abuses in the world's regions where they are extracted. Unsafe mining methods also lead to severe health problems for workers and environmental degradation in local communities. Since the mineral supply chain can include hundreds of suppliers, from mines and smelters or refiners to final production, making informed choices about mineral sourcing, from extraction to finished product, is challenging.

TCO Certified drives more responsible mineral sourcing in all countries where the mining industry and trade are present. Suppliers must adopt a responsible approach to mineral sourcing, irrespective of where they operate. TCO Certified goes beyond the current definition of conflict minerals and requires brand owners to include cobalt in their due diligence process. To drive widespread, positive impacts faster, due diligence and risk reporting are standardized, focusing on long-term, continuous improvement.

Applicability

All product categories.

2.4.1 Mandate

The brand owner must:

- Have a supply chain policy for responsible mineral sourcing for the certified product that can be considered to cover at least 3TG and cobalt. The policy must be both public and communicated to the supply chain.
- Conduct a reasonable country of origin inquiry for smelters or refiners (SORs) of at least 3TG and cobalt for the certified product that follows the OECD Due Diligence Guidance for Responsible Supply Chains of Minerals from Conflict-Affected and High-Risk Areas process.
- Annually demonstrate that at least 70% of the total number of SORs for 3TG and cobalt in the supply chain of the certified product are conformant (certified) to an accepted independent third party due diligence program.
- Annually submit the completed responsible mineral sourcing template with all the information required in the template.

Submit the following to an approved verifier:

- The most recent version of the public responsibly sourced minerals policy and a description of how it is communicated to the supply chain of the certified product.
- A description of the brand owner's structured work on identifying risk areas in the supply chain of the certified product with supporting documentation.
- The responsible mineral sourcing template (a TCO Certified template) and supporting documents must be completed and submitted to TCO Certified Portal before the brand owner annual due date stated in TCO Certified Portal and cover the supply chains of the final assembly factories of the certified product registered by the brand owner on TCO Certified Accepted Factory List.

The following is submitted to TCO Development:

- A copy of a verification report from a verifier approved by TCO Development.
- A copy of the responsibly sourced minerals policy in English. (Must be uploaded to TCO Certified Portal.)

2.4.2 Clarifications

Responsibly sourced minerals policy

The responsibly sourced minerals policy is an essential statement by the brand owner. It must reflect the brand owner's commitment toward responsible sourcing of minerals and the expectations that their raw material suppliers adhere to the policy.

Verification guidelines:

The verifier must verify that the responsibly sourced minerals policy can be considered to cover at least 3TG and cobalt for all the certified products, that it is public, and that it is clear how the policy is communicated to suppliers.

- "Public" means that the policy is visible on the brand owner's website or is included in the brand owner's annual sustainability or responsible minerals report, and that it is communicated that it covers all the brand names the brand owner has registered on the TCO Certified Portal.
- "Communicated" could be part of a contract and/or a written agreement with suppliers.

To verify the level of strictness, the policy must require at least the following:

- That suppliers uphold the policy.
- That suppliers neither directly nor indirectly finance armed groups in conflict-affected regions.
- That suppliers neither tolerate nor contribute to human rights abuses that include forced labor, child labor and environmental degradation.
- A commitment to supporting responsible sourcing from regions where specific mining operations may present risk.
- Suppliers work with the brand owner to identify SORs of 3TG and cobalt in the supply chain and report details using a conflict minerals reporting template (CMRT) or extended minerals reporting template (EMRT).
- That sourcing of 3TG and cobalt must be from SORs participating in third party audit programs aligned with OECD Due Diligence guidance and working toward certification.
- That action plans must be developed for SORs identified as not participating or certified to a third party audit program to remove them from the supply chain or have them participate in a program to obtain certification.

Structured work on identifying risk areas

The brand owner must carry out structured work to identify if at least 3TG and cobalt are present anywhere in the supply chain of the certified product, with the goal to identify the SORs. The verification of the structured work is carried out as part of the brand owner annual review process.

Identifying risk areas is a process that helps map the chain of custody of risk minerals down to the SORs within the supply chain. This is commonly done by a minerals reporting template being systematically sent through the supply chain. This transfer of information facilitates the identification of high-risk SORs.

Verification guidelines:

The verifier has been provided with a description of how the brand owner identifies risk areas in the supply chain of the certified product. The verifier can also require a copy of the completed minerals reporting template as further evidence of compliance. See the examples below:

- Using an established minerals reporting template as part of the brand owner's due diligence process. As a random follow-up at the request of TCO Development, completed examples of the template are to be submitted to the verifier.
- A public list of SORs on the brand owner website verifies that the brand owner has identified the list using a minerals reporting template.

Audited smelters or refiners (SORs)

Brand owners are required to annually submit information on the SORs identified as the source of 3TG and cobalt in the supply chain of the certified product. The required information identifies SORs that are conformant, active or otherwise registered through independent verification for their mineral sourcing due diligence process.

The brand owner must annually demonstrate the SORs that are conformant (certified) to an accepted responsible sourcing program and those that are considered to process scrap or recycled materials.

Verification guidelines:

The verifier must annually be provided with the responsible mineral sourcing template (a TCO Certified template) with the required columns covering information on the SORs identified as the source of 3TG and cobalt in the supply chains of the certified products.

The template section, 'Audited facilities' requires information about which SORs are in the supply chain of the certified product. SORs must be publicly registered as conformant with the Responsible Minerals Assurance Process (RMAP) or on the European Union (EU) 'white list'. Registered as 'active' or 'in-process' is not accepted as compliant. The verifier will compare the submitted information against the latest published list of conformant SORs using the comparison tool provided by TCO Development.

The brand owner can find their annual due date for submitting the responsible mineral sourcing template on TCO Certified Portal. The template is downloaded from tcocertified.com and must be submitted to the accepted verifier in time.

Audit program cross-recognition

RMAP cross-recognised audit programs are accepted. These presently include the London Bullion Market Association (LBMA) and the Responsible Jewellery Council (RJC). Other programs must first undergo independent verification to access the OECD due diligence

guidance implementation before being accepted as an alternative. The brand owner must provide proof of alignment to the accepted verifier for assessment.

Due diligence program information:

- The OECD Due Diligence Guidance for Responsible Supply Chains of Minerals from Conflict-Affected and High-Risk Areas (“OECD due diligence guidance”), available at [oecd.org](http://www.oecd.org). Brand owners require suppliers to disclose their sourcing origins of minerals using a questionnaire template such as the Responsible Minerals Initiative (RMI), conflict minerals reporting template (CMRT) or similar to prevent the potential use of risk minerals.
- Member of the Responsible Minerals Initiative (RMI). Members contribute to a number of tools and resources, including the conflict minerals reporting template, supporting in-region sourcing schemes and the Responsible Minerals Assurance Process (RMAP).
- Responsible Minerals Assurance Process (RMAP) helps companies make informed choices about responsibly sourced minerals in their supply chains. Independent third-party audits of SOR management systems and sourcing practices are used to validate conformance with RMAP standards. The assessment employs a risk-based approach to validate SOR company-level management processes for responsible mineral procurement.

The RMAP standards are developed to meet the OECD Due Diligence Guidance requirements, the Regulation (EU) 2017/821 of the European Parliament and the U.S. Dodd-Frank Wall Street Reform and Consumer Protection Act.

- EU ‘white list’ is a proposed list of SORs. The regulation (EU) 2017/821 promotes the responsible sourcing of SORs of tin, tantalum, tungsten and gold, whether they are based inside the EU or not. This is because EU importers must identify the SORs in their supply chains and check whether they have the correct due diligence practices. Whenever EU importers find SOR practices insufficient or associated with risks, they must manage and report on this.

To help companies, the European Commission is working to create a compliant list of global SORs which source responsibly.

References

1. <http://www.oecd.org/corporate/mne/mining.htm>
2. https://policy.trade.ec.europa.eu/development-and-sustainability_en
3. <https://www.responsiblemineralsinitiative.org/about/rmi-initiative/>

2.5 Process chemicals management

Background

Scientific research shows that workers who come into contact with chemical substances used in the manufacture of IT products are more likely to suffer from cancer, reproductive damage, birth defects and other serious illnesses.

The use of chemicals such as benzene and n-hexane (industrial cleaning solvents), which have well-documented toxic human health effects, have been restricted in some parts of the world but are often used by the manufacturing industry in developing countries where legislation is weaker, and workers are less protected. These chemicals need to be phased out of production and not be replaced with equally hazardous substances.

To replace chemicals with safer alternatives, process chemicals and their suitable safer alternatives must be identified and independently assessed by an approved toxicologist. The Personal Protective Equipment (PPE), training and exposure monitoring provided to the workers who risk chemical exposure also need to be reviewed and improved.

Applicability

All product categories.

2.5.1 Mandate

Each final assembly factory and factory manufacturing display panels >10" for the certified product:

- must have a structured health and safety management system independently certified to ISO 45001.
- must only use cleaning solvents for product components and PCB process cleaning that contain individual chemicals or formulations that appear on TCO Certified Accepted Substance List.
- must submit chemical inventory data covering at least cleaners, adhesives and lubricants.
- All substances of a mixture must be accounted for. Non-accepted substances must not exceed concentration levels of 0.1% by weight of the chemical product.

Submit the following to an approved verifier:

For each final assembly factory and factory manufacturing display panels >10" for the certified product:

- A valid ISO 45001 certificate must be uploaded to TCO Certified Portal before the stated due date.
- An accepted Process Chemical Template must be provided before the factory can be added to TCO Certified Accepted Factory List. Any updated submission to verify compliance must be submitted before the due date on TCO Certified Portal. The chemical data must at least cover the chemical formulations and ingredients shown in the chemical safety data sheet and used on the production lines where certified products are manufactured. An accepted Process Chemical Template can be downloaded at tcocertified.com

The following is submitted to TCO Development:

- A copy of a verification report from a verifier approved by TCO Development.
- For assessed substances, a copy of the assessment report issued by an approved licensed profiler independent of the accepted screened chemistry program. For GreenScreen certified formulations, a copy of the GreenScreen Certified certificate is acceptable.
- The process chemical data template must be reported in TCO Certified Portal.

2.5.2 Clarification

The cleaning process chemicals on the TCO Certified Accepted Substance List are commonly used by production lines to clean display panels, product enclosures, printed circuit boards, SMT machinery and tools.

The production lines manufacturing certified products must only use cleaners listed on the TCO Certified Accepted Substance List. To be included on the list, chemicals must be independently assessed and receive a GreenScreen® benchmark score of 2, 3 or 4 or ChemFORWARD hazard band A, B or C. GreenScreen certified platinum or gold set by a licensed GreenScreen Profiler is accepted for chemical formulations.

From the date a factory is registered on TCO Certified Portal and TCO Certified Accepted Factory List, a 12-month transition period to using only safer alternatives appearing on TCO Certified Accepted Substance List can be applied for. To keep the factory active on TCO Certified Portal, an updated process chemical data collection template must be re-submitted before the process chemical compliance due date on TCO Certified Portal.

Proof of health and safety management system conformity:

A valid ISO 45001 certificate must be uploaded to TCO Certified Portal for each registered factory that is in scope of this requirement. The certificate must be issued by a certification body that is accredited to issue the certification. Factories that do not yet have a certified health and safety management system according to ISO 45001, may apply to TCO Development for an extended period of up to 24 months to complete certification. This extended-time application template can be obtained from an accepted verifier. TCO Development has the right to deny the applicant an extended period if there is reason to believe the factory cannot achieve the ISO 45001 certification within the period (for example, if other critical non-compliance issues are pending or if the factory has a history of persistent audit non-compliance).

Process Chemical Data Collection Tool and Guidelines

An accepted Process Chemical Data Collection Tool must be completed and uploaded to TCO Certified Portal. The data must cover at least cleaning agents, adhesives and lubricants used to produce the certified product. The Process Chemical Data Collection Tool can be downloaded from tcocertified.com/certification-documents.

Completing the Process Chemical Template

- The senior representative at the factory, whose responsibilities cover chemical management, must assist the applicant in completing the accepted template.
- The areas that must be completed by the applicant are listed as 'required'.
- Listed chemical substances must show the CAS# number. The chemical supplier can directly submit this information to TCO Development if there are proprietary concerns. If a CAS# number is withheld, the chemical ingredient is treated as a restricted substance, and the cleaning product must be replaced with an accepted alternative. An alternative is to have the formulation GreenScreen Certified and listed by trade name only.
- The information must cover at least all chemical types required under the mandate and used to manufacture certified products.
- Upon request, the process chemical inventory at the factory must also be submitted for independent verification purposes.
- The template must be updated at the request of TCO Development.
- TCO Development has the right to compile confidential information with CAS numbers. TCO Development reserves the right to publish such compiled, anonymous information. Still, no information will be presented so that the company or the products in question can be identified.

Exposure controls and personal protective equipment (PPE)

TCO Certified Accepted Substance List reduces the risk of worker exposure to highly hazardous chemicals. However, safer alternatives do not remove the responsibility of the factory management to provide personal protection equipment as described in the chemical's safety data sheet (SDS), which covers exposure controls and personal protection. Verification of PPE (availability, training and use) is included in the ISO45001 standard and as part of the required factory audits (see mandate 2.1).

References

1. <https://www.iso.org/iso-45001-occupational-health-and-safety.html>
2. <http://www.centerforsustainabilitysolutions.org/clean-electronics/>

3 Environmentally responsible manufacturing

- Large amounts of natural resources and energy are used to manufacture IT products.
- This consumption can lead to soil, water and air pollution, as well as large greenhouse gas emissions.
- To reduce environmental risk, the environmental impact must be measured, and environmental and energy management systems must be in place.

Major environmental risks in the IT industry

Several environmental hazards occur throughout the IT product life cycle. The manufacturing process is a large risk. Harmful substances that are not handled safely risk ending up in nature. Life cycle assessments confirm that a significant part, sometimes the majority, of greenhouse gas emissions occur during the manufacturing phase, contributing to climate change. Another risk is the extensive use of natural resources in manufacturing, that may lead to increased climate impact and the loss of valuable, finite resources.

Our approach: regulating and incentivizing reduced environmental impact

With TCO Certified, the brand owner must have an environmental management system in place that is certified according to ISO 14001. This is to ensure continuous improvement in environmental performance and lowered environmental risks. Additionally, compliance with ISO 50001 is required to reduce energy use in manufacturing, with a focus on energy efficiency through annual reporting. Renewable electricity must be used in the manufacturing process and information on post-consumer recycled content is gathered to promote circular products. We also incentivize brand owners to reduce annualized PCF emissions by prolonging the product lifetime and reducing their scope 3 emissions.

Criteria in chapter 3 focus on:

- Lowering environmental risk and ensuring continual improvements by requiring that factories have an environmental management system in place which is certified according to ISO 14001.
- Lowering energy use in manufacturing by requiring compliance with ISO 50001
- Putting the spotlight on energy efficiency in manufacturing through annual reporting.
- Increasing the use of renewable energy in the manufacturing of certified products.
- Gathering information about post-consumer recycled content to help buyers identify more circular products.
- We are incentivizing brand owners to reduce annualized PCF emissions by prolonging the life of products and reducing their scope 3 emissions.

3.1 Environmental management system

Background

A certified environmental management system helps an organization work in a systematic way with environmental performance and make continuous environmental improvements. To be efficient, an environmental management system must include independent, external reviews.

Definitions

See definitions chapter 2.0

Applicability

All product categories.

3.1.1 Mandate

- Each final assembly factory and each factory manufacturing display panels >10" for the certified product must have a structured environmental management system that is independently certified to ISO 14001.

Submit the following to an approved verifier:

For each final assembly factory and factory manufacturing display panels >10" for the certified product:

- A valid ISO 14001 certificate must be uploaded to TCO Certified Portal before the stated due date.

The following is submitted to TCO Development:

- A copy of a verification report from a verifier approved by TCO Development.

3.1.2 Clarification

The applicant must ensure that a valid ISO 14001 certificate is available on TCO Certified Portal at all times, for every final assembly factory, and display panel factory that are registered to TCO Certified Portal as manufacturing certified products.

The certificate(s) or an appendix to the certificate(s) must make it clear what the certification covers.

If necessary the applicant may ask for an extended time period of up to 12 months on behalf of a factory that is not yet certified, by presenting a time plan for achieving the ISO 14001 certification and signing an agreement. TCO Development has the right to deny the applicant an extended period of time if there is a substantial risk that the factory will not be able to achieve ISO 14001 certification within the extended time period.

The certificate must be issued by a certification body that is accredited by an accreditation body covered by the International Accreditation Forum, iaf.nu, Multilateral Arrangement on Environmental Management Systems.

References

1. <https://www.iso.org/standards/popular/iso-14000-family>

3.2 Renewable energy

Background

As we face the challenges posed by climate change, it has become increasingly important for companies to transition to renewable energy sources. By increasing the share of renewable electricity in the final assembly of certified products, the product carbon footprint and climate impact of the certified product are reduced. This also increases the demand for Energy Attribute Certificates (EACs), which increase the economic incentive to build new generators for renewable electricity in many regions where most electricity is generated from non-renewable sources.

Applicability

All product categories.

3.2.1 Mandate

At least 15% of the electricity used in each final assembly factory of certified product must be procured and/or generated from renewable sources. This ratio must be reported yearly.

Submit the following to an approved verifier:

Once a year, and for each final assembly factory manufacturing certified products, the following must be proved:

- the total electricity used (MWh)
- the total renewable electricity ratio for the whole factory (%)
- the renewable electricity ratio for the brand owner's manufacturing of certified products at the factory (%)

The following is submitted to TCO Development:

- A copy of the verification report(s) from a verifier approved by TCO Development.
- For each final assembly factory manufacturing certified products, proof of the following must be reported in TCO Certified portal once a year:
 - the total electricity used (MWh)
 - the total renewable electricity ratio for the whole factory (%)
 - the renewable electricity ratio for the brand owner's manufacturing of certified products at the factory (%)

3.2.2 Clarification

Brand owner reporting

The reporting by the brand owner must be submitted by 31 August each year and applies until one year after the certificate has expired. The reporting must cover a consumption period (when the electricity was consumed by the factory) which must be the previous calendar year. This consumption period must be mentioned on the retirement statement of the EACs used. The production period of Energy Attribute Certificates (when the renewable electricity was generated) must be within 6 months before, and up to 3 months after the consumption period.

Exception for new factories

For factories where no TCO Certified Generation 10 product was certified (for any brand) before 31 August, the brand owners manufacturing at this factory must be in compliance the following calendar year. However, the brand owner must still report the renewable electricity share of their manufacturing (even if not in compliance), each 31 August.

Reporting for the whole factory or for a share of the manufacturing

Brand owners can choose to report on the whole factory level or only on their share of the manufacturing. Reporting on their share of the manufacturing is useful if they want to purchase additional EACs for their own manufacturing to achieve a higher ratio than the factory. In this case, the share of the total electricity used to manufacture products for the brand owner is estimated to be the same as the brand owner's share of the factory's revenue or manufacturing volume.

If a product is manufactured at several final assembly factories, the reporting must cover the manufacturing at each factory, and each must pass the criterion. (Combining the factories in an average value is not allowed.)

For each reporting period and final assembly factory, the brand owner must report the following:

If the ratio of renewable electricity used by the factory is $\geq 15\%$, reporting may be done only on the factory level and must include:

- Documented proof of the total electricity consumption of the factory (X)
- Any EACs designated to the factory (with the factory name) for the renewable electricity (Y) generated or purchased by the factory during this period.

Calculations:

- The ratio of renewable electricity by the factory ($R_F = Y/X$).

Otherwise, reporting must be more detailed and include:

- Documented proof of the total electricity consumption of the factory (X)
- Any EACs designated to the factory (with the factory name) for the renewable electricity generated or purchased by the factory during this period (Y).
- Documented proof to estimate the brand owner's share of the electricity consumption:
 - by the total number of units manufactured (Z) and the number of units manufactured for the brand owner (W) during the period.
 - or by the total revenue of the factory (Z) and the revenue for the brand owner's manufacturing at the factory (W) during the period.
- Any EACs (S) designated to the factory and brand owner (with the factory name and brand name) for the manufacturing of products for the brand owner at the factory.

Calculations:

- Estimated electricity used to manufacture products for the brand owner ($E = X/Z \cdot W$)
- Ratio of renewable electricity for all manufacturing at the factory ($R_F = Y/X$).
- Ratio of renewable electricity only for the brand owners manufacturing ($R_B = S/E$)
- Total ratio of renewable electricity for the brand owners manufacturing ($R_T = R_F + R_B$)

Renewable electricity must be generated from:

- Wind,
- Solar,
- Geothermal,
- Hydropower (pumped hydro storage is only accepted if the amount of grid-imported electricity used to run the pumps is specified on the submitted EAC and deducted from the generated electricity)
- Biomass (agriculture waste and residues, forest biomass, biofuels plants)

Energy Attribute Certificates (EACs)

Renewable electricity can be purchased or generated by the factories. Generators might be on-site or off-site, on the grid, or entirely off-grid. The generation must be issued with Energy Attribute Certificates (EACs). Factories can consume directly from their generators, retain the EACs and claim the use of renewable electricity. They can also sell electricity to the grid, retain the EACs, and claim the use of renewable electricity.

Both for self-generation and market-purchased EACs, the attributes (and certificates) must be sourced and purchased from within the same national region as the factory using the electricity. Also, the renewable electricity production facility for which the certificates are issued must be within the same national region. The national region constitutes a "market" for the purpose of transacting and claiming attributes.

Exception for a high market price of EACs

If the market price of all accepted EACs in the market in question is above 10 USD / MWh it is allowed to source accepted EACs accounting for 30% of the renewable electricity purchased from markets with neighboring borders.

If the market price of all accepted EACs in the market in question is above 30 USD / MWh, it is allowed to source accepted EACs accounting for 70% of the renewable electricity purchased from markets with neighboring borders. (For Taiwan EACs may be purchased from China, Japan, Philippines and South Korea under this exception.)

An EAC must be recognized on the list below to be accepted as proof of compliance. Other countries and credible systems may be added to the list after independent review and acceptance from TCO Development.

Country	Accepted EACs
Brazil	I-REC
Canada	REC, I-REC
China	I-REC, GEC, TIGR
Czech Republic	EECS-GO
Egypt	I-REC
Hungary	EECS-GO
India	I-REC, Indian national EAC system, TIGR
Japan	J-Credit, FIT-NFC, GEC
Malaysia	I-REC, TIGR
Mexico	I-REC
Poland	National Guarantees of Origin
Portugal	EECS-GO
Singapore	I-REC, TIGR
Taiwan	T-REC, I-REC, TIGR, (CPPA is not an EAC but allowed)
Thailand	I-REC, TIGR
USA	REC, I-REC
Vietnam	I-REC, TIGR
South Korea	Korean national EAC system, TIGR

Verification guidelines of factory data

At a minimum, this criterion requires documented proof of total electricity consumption and EACs designated to the factory.

For brands that prefer to report on their own share of the manufacturing instead of on the whole factory level, the following proof is also required:

- A copy of all EACs designated to the brand owners manufacturing at the factory
- One of the following
 - Documented proof of the total units manufactured by the factory and the share of units manufactured for the brand owner.
 - Documented proof of the total revenue for the factory and the share of revenue for the brand owners manufacturing at the factory.

Examples of documentation to prove a factory's annual electricity use normally include energy bills, metering records, energy audits, and monitoring system data. (The total is added to the Accepted Factory List and only needs to be verified once per factory and year.)

Examples of documentation to prove a factory's annual total revenue or number of units manufactured, as well as the revenue share or number of units manufactured for the brand owner during the period, typically include production records, shipping logs, internal financial documents, external audits, and contractual agreements. It must be a copy of a document or digital system that can be verified during an onsite audit. (The brand owner share is added to the Accepted Factory List and only needs to be verified once per factory, brand name and year).

Verification of Energy Attribute Certificates (EACs)

The brand owner must present proof that Energy Attribute Certificates are exclusively owned by, have been permanently retained by or retired on behalf of the specific factory or by the brand manufacturing at the specific factory. This means that EACs designated to the factory must have the factory name on them, and EACs designated to the brands manufacturing at the factory must have both the factory name and brand name on them (to avoid double counting).

Energy Attribute Certificates are part of tracking systems in which certificates are electronically serialized and issued to generators with accounts on the system. There, they are traded and ultimately permanently retired when they are used to support a claim.

For more information on how to verify the authenticity of the EAC with each certificate body, a guideline can be found here: <https://tcocertified.com/industry/certification-documents/>

Simplified verification process of EACs:

1. The authenticity of the EAC is verified with the relevant EAC certificate body.
2. The consumption period is the previous calendar year
3. The production period of EAC (when the renewable electricity was generated) is within 6 months before, and up to 3 months after the previous calendar year.
4. The amount of renewable electricity that is represented by the EAC.
5. The certificate ownership is to the specific factory (and brand owner) in question.
6. The certificate is retired (not for sale) when making a claim about renewable energy.

3.3 Energy management system

Background

A certified energy management system helps an organization work in a systematic way with energy performance and make continuous improvements at both company and product levels. To be efficient, an energy management system must include independent, external reviews.

Definitions

See definitions chapter 2

Applicability

All product categories

3.3.1 Mandate

- Each final assembly factory and each factory manufacturing display panels >10" for the certified product must have a structured energy management system independently certified to ISO 50001.

Submit the following to an approved verifier:

For each final assembly factory and factory manufacturing display panels >10" for the certified product:

- A valid ISO 50001 certificate must be uploaded to TCO Certified Portal before the stated due date.

The following is submitted to TCO Development:

- A copy of a verification report from a verifier approved by TCO Development

3.3.2 Clarification

The applicant must ensure that a valid ISO 50001 certificate is available on TCO Certified Portal at all times for every final assembly factory and each factory manufacturing panels >10" for the certified product. The certificate(s) or an appendix to the certificate(s) must clarify what the certification covers.

Factories that do not yet have a certified energy management system according to ISO 50001, may apply to TCO Development for an extended period of 24 months to complete certification by annually submitting an extension application on the certification status. This application and status template can be obtained from TCO Development.

TCO Development has the right to deny the applicant an extended period if there is a substantial risk that the factory will not be able to achieve ISO 50001 certification within the extended period. The certificate must be issued by a certification body accredited by an accreditation body covered by the International Accreditation Forum, iaf.nu, Multilateral Arrangement on Energy Management Systems

References

1. <https://www.iso.org/iso-50001-energy-management.html>

3.4 Post-consumer recycled content

Background

Use of recycled materials lowers the environmental impact. For example, in the manufacturing of plastics, if 100% recycled content is achieved, can reduce energy consumption by up to 60%, compared to virgin plastics. Less raw materials are required to produce recycled plastics, which can lead to a reduced carbon footprint. Every metric ton of recycled plastic produced can result in up to 1-3 metric tons of carbon dioxide savings, compared to virgin plastics.

The long-term goal is that all materials in certified products are circulated and renewable where technically possible.

Definition

PCR – Post-consumer recycled: Post-consumer recycled materials are derived from used consumer products, often packaging, bottles and durable goods, including IT products. (I.e. aluminum cans, PET bottles). This does not include PCM material.

PCM - “Pre-consumer Material”: Material or by-products generated during the manufacturing of a product but before the product reaches the end-use consumer.

Applicability

All product categories.

3.4.1 Mandate

The following information for the worst-case configuration (lowest PCR content ratio) of the certified product (including any external power supply) must be reported:

- Percentage of post-consumer recycled plastics by weight versus the total weight of all plastics.
- Percentage of identified post-consumer recycled materials (plastic and non-plastic) by weight versus the product weight.

Submit the following to an approved verifier:

- The completed post-consumer recycled content & packaging template
- Documented proof for all parts claiming PCR content.

The following is submitted to TCO Development:

- A copy of the verification report(s) from a verifier approved by TCO Development.
- Documented proof for all parts claiming PCR content.

The following is submitted to TCO Development and may be published:

- The weight of all plastics in the product.
- The weight of all post-consumer recycled plastics and other identified post-consumer recycled material in the product.

3.4.2 Clarification

The worst-case configuration (lowest PCR content by weight of total product weight) that is available for purchase must be defined and stated in the verification report. It must be defined through a unique brand owner code, a unique product identifier, or a list of configuration choices that are available at the time of purchase. *If there are several versions of the same component (e.g. due to different suppliers), then the worst-case version of the component must be reported.)*

All plastic parts with a weight above 0.5 grams must be accounted for in the Post-consumer recycled content & packaging template. Parts that are non-plastic and without PCR content do not need to be listed individually.

Documented proof from an independent third party covering each part containing post-consumer recycled material must be provided if it is to be included in the PCR percentage. TCO Development has the right to require a full bill of material.

It is possible to report a second configuration or a “best case” PCR content ratio through a separate submission of the Post-consumer recycled content & packaging template. Doing so will result in a range being presented for the product on TCO Certified Product Finder

Exceptions plastics

Optical components and display panels, electronic components, cables, connectors, PCBs, insulating mylar sheets, hard sheets for insulation, soft sheets for heat dissipation, elastomer feet, sponge materials, and labels may be excluded. This means that the weight of these items is not included when calculating the total weight of the plastics in the product. The total product weight for the configuration is calculated, including these parts.

The following information must be submitted to an approved verifier

For each plastic part with a weight above 0.5g, the following must be reported:

- Name of part/part ID
- Material manufacturer name
- Identification marking of PCR material
- Weight of part (grams)
- Weight of plastics in part
- Weight of post-consumer recycled content (grams)

For other identified post-consumer recycled content:

- Name of part/part ID
- Material manufacturer name
- Type of material
- Weight of part (grams)
- Weight of post-consumer recycled content (grams)

The post-consumer recycled content & packaging template is available at tcocertified.com/certification-documents

3.5 Annualized PCF with scope 3 reductions

Background

One way to estimate a product's climate impact is to make a Product Carbon Footprint (PCF) report. PCFs cover the whole life cycle of a product, from the raw material extraction to the recycling or disposal phase.

The main purpose of working with PCFs should be to use this understanding to reduce the climate impact of IT products. However, there are numerous ways to achieve a lower PCF result in a report for a product without reducing its climate impact. For example, the choice of calculation method, assumptions and source data used can significantly reduce the calculated PCF result for a product without reducing its climate impact.

Two important ways to actually reduce the climate impact of IT products are to prolong their functional life before a replacement is needed and to improve their design and manufacturing to reduce their scope 3 carbon footprint. To incentivize these activities, TCO Development presents certified products with an annualized PCF estimation which depends on the supported lifetime and implemented reductions of scope 3.

This will emphasize for purchasers the intended lifetime of the product and the reduced annual climate impact if the product is used that long. It will recognize products where brand owners support a longer lifetime and where design and manufacturing have been improved beyond the industry average to reduce the climate impact in scope 3.

Applicability

All product categories.

3.5.1 Mandate

An annualized PCF value must be estimated for the certified product based on a scope 2 and 3 default value for the product category, the supported product lifetime and any approved implemented scope 3 reductions.

Submit the following to an approved verifier:

- If any scope 3 reductions are claimed, documented proof of the implementation of these covering the certified product must be provided.

The following is submitted to TCO Development:

- A copy of the verification report(s) from a verifier approved by TCO Development.
- All verified scope 3 reduction solutions, and the total estimated scope 3 reduction must be reported in TCO Certified Portal.

The following is submitted to TCO Development and may be published:

- All verified scope 3 reduction solutions and their total estimated reduction.

3.5.2 Clarification

For products where no reduction solutions are claimed, no documentation needs to be provided to the verifier or TCO Development under this criterion.

This criterion is not applicable to some product categories that will be presented by TCO Development without the annualized PCF value until a scope 2 and 3 default value has been established for the product category. The scope 2 and 3 default values are averages of the scope 2 and 3 components in a large number of PCFs in each product category. These values may be updated from time to time to reflect products available on the market. The list of currently applicable product categories and the methodology of how the default values are developed is explained here: <https://tcocertified.com/industry/certification-documents/>

TCO Development will estimate and publish an annualized PCF value for each certified product. This annualized PCF value is the sum of an annualized scope 2 and scope 3 component.

- The scope 2 component is an annualized default value for each product category representing the climate emissions for one year of use.
- The scope 3 component consists of a scope 3 default value for each product category minus any approved scope 3 reduction solution. This is then divided by the supported product lifetime to get the yearly scope 3 value (annualized).

$$PCF_{Annualized} = \frac{(Scope\ 3_{default} - Scope\ 3_{deduction})}{Supported\ product\ lifetime} + Scope\ 2_{default\ per\ year}$$

The supported product lifetime is determined by TCO development based on the shortest duration of the available warranty and software update periods. The scope 3 reductions are determined by TCO Development based on a list of best practice solutions to reduce the product carbon footprint in scope 3. This best practice list is populated continuously as brand owners provide suggestions on best practice reduction solutions, and independent experts evaluate them to determine how much they exceed the industry average and what reduction should be awarded.

Claiming a reduction of the default value

A list of best practice solutions to reduce the PCF will be published by TCO Development and expanded over time here: <https://tcocertified.com/industry/certification-documents/>

To claim a best practice reduction solution on the list, a brand owner must provide documented proof of the implementation of the solution covering the certified product.

Adding new best practices reduction solutions to the list

New solutions may be added to the list as they are accepted by TCO Development. If a brand owner believes they have implemented solutions that reduce the Scope 3 product carbon footprint beyond the industry average, they can apply to TCO Development for evaluation. An independent expert will assess the solution, and upon approval by TCO Development, it will be added to the list.

To qualify for the list of best practice reduction solutions, the following criteria must be met:

- The solution must contribute to a significant reduction in the Scope 3 product carbon footprint compared to the industry average for the product category.

- The reduction in Scope 3 emissions can be estimated in a credible manner.
- The solution should be formulated so that it is not limited to a specific brand owner.
- There must be a credible methodology for implementing and verifying the solution, which TCO Development can make public.

Brand owners can submit a description of their solution to an approved independent expert, who will determine if the solution meets the requirements. If it does, the solution will be added to the list of best practice reduction solutions.

The purpose of this list is to recognize brand owners who have a deep understanding of Scope 3 climate footprint reductions. By sharing their solutions with other brand owners, they can gain approval for their methods and subsequently claim a lower estimated annualized PCF value for their certified products. Over time, this will result in a list of field-tested Scope 3 PCF reduction solutions assessed by experts, making a significant impact beyond the industry average. Each solution is presented with a methodology for implementation and verification.

4 User health and safety

- A poorly designed IT product may cause injury and health problems for the user.
- Fire hazards, electric shock and explosions are some of the risks associated with substandard products. They may also have a short lifespan which is negative from a sustainability perspective.
- An IT product that is independently verified to be safe to use supports productivity and can meet the user's needs longer.

Poor product design is a safety hazard

Product safety and functionality are fundamental to sustainability in the IT sector. Unsafe products often have a short lifespan which leads to pollution, e-waste and high resource consumption. They may also cause health and safety problems for the user. Examples of identified safety hazards include product overheating and risk of fire, battery volatility which can lead to burning or explosion, and poor electrical safety design that may increase the risk of fire or electric shock.

Our approach: verifying product safety, protecting the user

An IT product must be safe to use and should provide the user with the necessary function and comfort for a long time. To be efficient, criteria for user health and safety aspects must be specific and tailored to each product category.

Criteria in chapter 4 focus on:

- Requiring that products are safe to use and that the user's risk of injury is minimized.
- Making sure that any cases of burning, explosion and electric shock are prevented.
- Limiting specific risks through criteria adapted for certain product categories.

4.1 Electrical safety

Background

IT products must be safe to use. Electrical safety refers to the electrical design of the product. Electrical insulation and other arrangements must be in place to prevent the user from touching live components. Faulty or inadequate electrical insulation can also result in an electrical flashover that may cause a fire or an explosion.

Applicability

All products with built-in or external power supplies.

4.1.1 Mandate

The product and external power supply/supplies must be certified according to IEC 62368-1 edition 2 or newer.

Submit the following to an approved verifier:

- A copy of a valid CB certificate for the product.
- For each external power supply shipped with the product:
 - A copy of a valid CB certificate or a national certificate from a CB member (NCB) for the external power supply
 - The manufacturer and model name
 - The external power supply's protection classification

The following is submitted to TCO Development:

- A copy of the verification report(s) from a verifier approved by TCO Development.

4.1.2 Clarification

For products classified as medical equipment, IEC 60601-1 version 3.2 or newer can be used instead of IEC 62368-1.

References

IEC62368-1 Audio/video, information and communication technology, Part 1 -Safety requirements

5 Product performance

- A low-performing product can reduce user productivity and satisfaction. It may therefore be discarded prematurely.
- High energy consumption can lead to large emissions of greenhouse gases, which contributes to the climate crisis.
- By taking both product performance and environmental factors into account, user productivity can improve and the device can be in use for a longer time.

Low product performance reduces productivity and is a sustainability risk

Product performance is essential for user satisfaction and productivity. Low-performing products are also problematic from a sustainability perspective – in many cases, these products have a shorter lifespan, which leads to pollution, e-waste and high resource consumption. Discarding products prematurely is often also more costly for the purchasing organization.

Our approach: balancing product performance with energy efficiency

Product performance, user satisfaction and the development of more circular IT products are interconnected. In order for IT products to be more sustainable, all these factors need to be prioritized. Balancing product performance with energy efficiency is also important to reduce the product's climate impact.

High-performance products can meet the user's needs for a longer period of time. This way, the product's service life can be extended, which is an extremely important factor in reducing resource consumption, reducing greenhouse gas emissions and the amount of e-waste produced. Using the product for a longer time is also often better from an economic perspective, and provides a lower total cost of ownership for the purchasing organization.

Criteria in chapter 5 focus on:

- Requiring that product performance is balanced with energy efficiency through specific criteria for each product category.

5.1 Energy efficiency

Background

The IT industry and people's IT usage are large sources of greenhouse gas emissions, which remain the leading factor in climate change. As the number of IT equipment in use grows, greenhouse gas emissions are also increasing. Reducing the problem requires a number of measures, of which energy-efficient products are one part.

This criterion focuses on energy efficiency in the use phase and helps purchasing organizations independently verify that the IT product they source meets the energy efficiency requirements of ENERGY STAR.

Applicability

Notebooks, tablets

5.1.1 Mandate

The energy consumption and power supply requirements in version 8 of the ENERGY STAR® program for computers must be fulfilled.

Submit the following to an approved verifier:

- A copy of the test report(s) from a laboratory accredited according to ISO 17025.

The following is submitted to TCO Development:

- A copy of the test report(s), and a copy of the verification report(s) from a verifier approved by TCO Development.

The following is submitted to TCO Development and may be published:

- The measured energy values and product configuration must be reported in TCO Certified Portal

5.1.2 Clarification

The product must be tested according to version 8 (or a more recent version) of the ENERGY STAR program for computers. Testing can be carried out at any test facility accredited according to ISO 17025, but the test report must be verified by a verification organization approved by TCO Development. The minimum version of EnergyStar that all product configurations are able to meet will be presented on the certificate.

Testing only needs to cover the energy consumption requirements and the power supply requirements of that program. The product does not need to be ENERGY STAR certified to be approved for TCO Certified.

Measured energy consumption according to ENERGY STAR®, as well as Typical Energy Consumption (TEC) and the allowed maximum consumption (TEC_MAX) for each category (I1-I2, D1-D2, 0-2 or Thin Clients) must be submitted to TCO Certified Portal, together with the application.

For each tested configuration, at least the following properties must be reported on the test report:

- Processor brand
- Processor model
- System memory (GB)
- Integrated or dedicated GPU
- Operating system name
- PSU if applicable

Exceptions and special requirements

All exceptions and special requirements, test methods etc. that are accepted by ENERGY STAR are also accepted by TCO Development.

Products that are covered by another ENERGY STAR product specification must be tested according to that specification.

References

1. ENERGY STAR® Program Requirements - <https://www.energystar.gov/products/>

Visual ergonomics

Good visual ergonomics is a very important aspect of quality that can also have a direct effect on the health, comfort and productivity of the user. Good ergonomics, such as a high quality display image, can also influence our productivity and extend the usable life of a product. In this way, ergonomic design can also offer sustainability benefits.

In developing criteria for visual ergonomics, the possible health effects of various parameters have been taken into account. Other features that characterise high quality displays have also been in focus when developing these criteria.

TCO Development used three main methodologies to determine suitable levels and test methods for the visual ergonomics criteria:

1. Acceptable visual levels, as determined by scientific research.
2. Statistics from tests carried out in accordance with TCO Development, ISO, MPR regulations and from specialized VDU tests.
3. Manufacturers' knowledge and experience, which is invaluable. Manufacturers, consumer groups and other organisations with interests in the visual ergonomics field have contributed a great deal of valuable information and ideas throughout the development process.

5.2 Display resolution

Background

Image quality is negatively affected by a low fill factor, visible “jaggies”, poor rendering of details etc. All of these parameters are related to the resolution of the display. For display resolution characteristics, it is important to take the viewing distance into account.

Definition

A pixel is the smallest addressable imaging element of the display panel capable of reproducing a full range of luminance and colors.

Applicability

Tablet computers.

5.2.1 Mandate

The display panel should have a pixel density of at least 145 PPI.

The following is submitted to TCO Development:

- A copy of the test report(s), and a copy of the verification report(s) from a verifier approved by TCO Development.

The following is submitted to TCO Development and may be published:

- The pixel density, resolution, panel size and aspect ratio must be reported in TCO Certified Portal.
-

5.2.2 Clarification

145 PPI gives a reasonable image quality at a viewing distance of 40cm, which can be regarded as a normal viewing distance to a tablet placed in your lap, based on anthropometric data.

Preparations for testing

No specific preparation of the product is needed.

Equipment

Calibrated ruler for the diagonal measurement. Product manual or similar information about the display resolution.

Test method

The maximum resolution and size of the display panel are found in the manual or in a similar information document from the manufacturer. Verify the diagonal distance in inches rounded to one decimal and calculate the PPI.

Test evaluation

The pixel density (PPI, pixels per inch) should be calculated as following:

$$PPI = \frac{\sqrt{\text{horizontal pixels}^2 + \text{vertical pixels}^2}}{\text{the diagonal of the panel in inches}}$$

Overall uncertainty

Measurement uncertainty in diagonal measurement is $\leq \pm 2\text{mm}$. Product data information is sufficient.

See chapter 9

References

1. Flat Panel Display Measurements Standard, (FPDM), Version 2.0, VESA - Video Electronics Standards Association Display Metrology Committee. June 1, 2001, CA 95035, Milpitas.

5.3 Correlated color temperature

Background

Physical measurements of color stimuli can only give an indication of the color appearance in a practical situation. The color of the frame, the spectral composition of the lighting, the color of various areas in the visual field, and the complexity of brightness variations in the visual field all influence the color appearance of an tablet display image.

It is important to be able to set a color temperature that represents average daylight. It will be intuitive to most users to have their document background and photo editing in this color temperature as this is a light source that users will be exposed to daily. Average atmospheric filtered daylight has a correlated color temperature of approximately 6500K and is reproduced by a number of standards ex. D65, sRGB, ITU rec 709 which are widely used in photo and video editing.

Definition

The correlated color temperature is a measure of the perceived screen color expressed in Kelvin (K).

Applicability

Non monochromatic tablet computers with backlit or light emitting pixels.

5.3.1 Mandate

The product default preset correlated color temperature may have any name but must have a color difference $\Delta u'v' \leq 0.02$ when compared to CIE u' and v' chromaticity coordinates for D65.

The following is submitted to TCO Development:

- A copy of the test report(s), and a copy of the verification report(s) from a verifier approved by TCO Development.
 - The measured values must be reported in TCO Certified Portal.
-

5.3.2 Clarification

Preparations for testing

- All necessary preparations described in chapter 9 must be done.
- A TCO Certified default test image, as shown in figure 9.1.7, must be used for this measurement.

Equipment

Spectro-radiometer capable of presenting CIE u' and v' chromaticity coordinates with at least three decimals.

Test method

The spectral properties at the center of the measurement area must be measured with a spectroradiometer. The spectral data must then be processed, which is normally done directly in the instrument's microprocessor, to give chromaticity coordinates. In this case, the CIE coordinates u' and v' are needed for the test evaluation and are often presented directly by the spectro-radiometer used.

Test evaluation

CIE $u'v'$ chromaticity coordinates for D65.

u'	v'
0,1979	0,4683

If the spectro-radiometer used only can produce CIE 1931 x and y chromaticity coordinates, these can be transformed to u' and v' chromaticity coordinates by using the formulae in the CIE Publication 15.2 (reference 5.17). The relevant CIE material – conversion formulae and tabulated data for u'_{CCT} and v'_{CCT} – can also be found on the TCO Certified website: tcocertified.com.

The resulting color difference calculation must be presented to 3 decimal places.

Overall uncertainty

$\leq \pm 0.003$ in u' and v' .

See chapter 9

References

1. Flat Panel Display Measurements Standard, (FPDM), Version 2.0, VESA - Video Electronics Standards Association Display Metrology Committee. June 1, 2001, CA 95035, Milpitas.
2. Wyszecki, G., Stiles, W.S., (1982) Colour Science: Concepts and methods, quantitative data and formula, Second Edition, John Wiley & Sons, Inc. Chapter 7, Visual thresholds, pp 574-575.
3. Hunt, R.W.G. Measuring colour. 3rd edition (1998), Kingsley-Upon-Thames: Fountain Press.
4. CIE Publication 15.2 (1986), Colorimetry, p. 11, p.27-28 and p. 53-54, table 1.3).
5. Roberts, A., Eng, B., (1995) "A method for the calculation of tolerances for display primary chromaticity coordinates" Research and development Department, Technical Resources, The British Broadcasting Corporation.
6. ISO TC130 WD 12646 p. 5 Section 4.7 Chromaticity and luminance of the white and black points and tracking.

7. ITU-R Recommendation BT.709-5: Parameter values for the HDTV standards for production and international programme exchange
8. <http://www.w3.org/Graphics/Color/sRGB.html>
9. SMPTE RP 145-1994: SMPTE C Colour Monitor Colorimetry
10. IEC 61966-2-1 (1999-10) Multimedia systems and equipment - Colour measurement and management - Part 2-1: Colour management - Default RGB colour space – sRGB.
11. ITU-R Recommendation BT.470-6: Conventional television systems.
12. Schenkman, B., and Kjeldahl, L. (1999). Preferred colour temperature on a colour screen. Displays, 20, 73 - 81.
13. www.srgb.com
14. Le Grand, Y. (1957). Light, colour and vision. Chapman and Hall.
15. Le Grand, Y. (1957). Light, colour and vision. Chapman and Hall, Chapter 12, Colour difference thresholds p. 279.

5.4 Color gamut

Background

Accurate color rendering is important when realistic color images or color presentations are presented on the tablet display. Poor color rendering can lead to poor readability and misinterpretation.

Applicability

Non monochromatic tablet computers with backlit or light emitting pixels.

5.4.1 Mandate

The minimum color triangle must have the following coordinates:						
	Red		Green		Blue	
Coordinate	u'	v'	u'	v'	u'	v'
Requirement	≥ 0.375	≥ 0.503	≤ 0.160	≥ 0.548	≥ 0.135	≤ 0.305

The following is submitted to TCO Development:

- A copy of the test report(s), and a copy of the verification report(s) from a verifier approved by TCO Development.
- The measured values must be reported in TCO Certified Portal.

5.4.2 Clarification

The u' and v' chromaticity coordinates of the primary colors red (R), green (G) and blue (B) of the screen must aim at values given in international IEC, EBU and ITU standards. The u' and v' chromaticity coordinates of the primary colors R, G and B form a triangle in the CIE 1976 uniform chromaticity scale diagram. The larger the area of the triangle, the wider the range of colors the screen is capable of presenting.

The color characteristics of a tablet display are based on the visual appearance of the tablet display primary color stimuli, the R, G, B-stimuli.

Preparations for testing

- All necessary preparations described in chapter 9 must be done.
- A TCO Certified default test image, as shown in figure 9.1.7, must be used for this measurement.
- The measurement area must have each of the following RGB settings: (255, 0, 0) for red, (0, 255, 0) for green, (0, 0, 255) for blue.

Equipment

Spectro-radiometer with a capacity to present u' and v' coordinates to at least 3 decimal points.

Test method

The instrument must be directed orthogonally towards the different test square centers at the measurement distance described in chapter 9. Measure the chromaticity coordinates at the center of the measurement area for each color setting specified above or alternatively, the larger measurement area image (80% of the active screen area) described in chapter 9 may be used for these measurements. Change the color of the area for each measurement.

Test evaluation

The recorded chromaticity coordinates u' and v' for the red, green and blue squares must be reported.

The u' and v' must be presented to 3 decimal places.

Overall uncertainty

$\leq \pm 0.003$ in u' and v' for red and green.

$\leq \pm 0.007$ in u' and v' for blue.

See chapter 9.

References

1. Wyszecki, G., Stiles, W.S., (1982) Colour Science: Concepts and methods, quantitative data and formula, Second Edition, John Wiley & Sons, Inc. Chapter 7, Visual thresholds, pp 574-575.
2. Hunt, R.W.G. Measuring colour. 3rd edition (1998), Kingsley-Upon-Thames: Fountain Press.
3. CIE Publication 15.2 (1986), Colorimetry, p. 11, p.27-28 and p. 53-54, table 1.3).

4. Roberts, A., Eng, B., (1995) "A method for the calculation of tolerances for display primary chromaticity coordinates" Research and development Department, Technical Resources, The British Broadcasting Corporation.
5. ISO TC130 WD 12646 p. 5 Section 4.7 Chromaticity and luminance of the white and black points and tracking.
6. ITU-R Recommendation BT.709-5: Parameter values for the HDTV standards for production and international programme exchange
7. <http://www.w3.org/Graphics/Color/sRGB.html>
8. SMPTE RP 145-1994: SMPTE C Colour Monitor Colorimetry
9. IEC 61966-2-1 (1999-10) Multimedia systems and equipment - Colour measurement and management - Part 2-1: Colour management - Default RGB colour space – sRGB.
10. ITU-R Recommendation BT.470-6: Conventional television systems.
11. www.srgb.com
12. Le Grand, Y. (1957). Light, colour and vision. Chapman and Hall.
13. Le Grand, Y. (1957). Light, colour and vision. Chapman and Hall, Chapter 12, Colour difference thresholds p. 279.
14. E.B.U. Standard for chromaticity tolerances for studio monitors Tech. 3213-E August 1975.
15. SMPTE 170M-1999 Television - Composite Analogue Video Signal - NTSC for Studio Applications.

5.5 Color uniformity

Background

The human visual system is very sensitive to changes in color hue in white and gray areas. White and gray color hues also serve as reference colors on the screen, that affect how all other colors are perceived. Patches of color variation on an active white or gray screen may reduce the contrast, be disturbing and affect readability, color rendering and color differentiation.

Definition

The color uniformity of a display is the capability to maintain the same color on any part of the screen.

Applicability

Non monochromatic tablet computers with backlit or light emitting pixels.

5.5.1 Mandate

The maximum color deviation between measured active areas on the screen that are intended to maintain the same color must be $\Delta u'v' \leq 0.012$.

The following is submitted to TCO Development:

1. A copy of the test report(s), and a copy of the verification report(s) from a verifier approved by TCO Development.
 2. The measured value must be reported to TCO Certified Portal.
-

5.5.2 Clarification

Preparations for testing

- All necessary preparations described in chapter 9 must be done.
- The entire active area of the screen must be white and the display color setting must be RGB 255, 255, 255.

Equipment

Spectroradiometer with a capacity to present u' and v' coordinates with at least 3 decimals.

Test method

The color uniformity must be measured orthogonally to the tablet screen plane at 9 points. The 4 corner positions (1, 3, 7 and 9) are measured 1° from the edges of the screen as shown in *luminance uniformity 1*. The 4 side positions (2, 4, 6 and 8) are measured on the middle of the side 1° from the edge. These measurement points have a $1/2^\circ$ margin to the edges if the measurement area of the instrument is 1° (see figure *luminance uniformity 1*). Finally the center position (5) is measured.

The color uniformity must also be evaluated visually by the technician in order to find those areas where the color varies the most except from the 9 default positions. If a significant difference within the 1° from the edge area is found these measuring points must also be measured and used to evaluate the color uniformity.

The conditions for color measurement in the corner positions and the distribution of other measurement points are illustrated in figure *luminance uniformity 1*.

Test evaluation

$\Delta u'v'$ according to the CIE (1976) uniform chromaticity scale diagram must be calculated for each measured position using the formula

$$\Delta u'v' = \sqrt{(u'_A - u'_B)^2 + (v'_A - v'_B)^2}$$

where A and B are the two points found to have the largest color difference between them.

The largest difference in $u'v'$ value must be reported.

The result must be presented to 3 decimal places.

(The evaluation procedure is exemplified below)

- Make a table of color chromaticity values for each measured position

Measurement position no.	u'	v'
1	0.190	0.447
2	0.186	0.441
3	0.186	0.437
-	-	-
n-1	0.185	0.434

n	0.186	0.432
Largest difference	0.005 in this example	0.015 in this example

- The largest u' difference, $\Delta u'$, is 0.005 (between 0.190 and 0.185) at measurement positions 1 and n-1.
- The largest v' difference, $\Delta v'$, is 0.015 (between 0.447 and 0.432) at measurement positions 1 and n.
- Since $\Delta v'$ (= 0.015) is much larger than $\Delta u'$ (= 0.005), the $\Delta v'$ value must be used for the calculation of $\Delta u'v'$.
- The corresponding two pairs of u' and v' to be used for the calculation are thus the values found at position 1 and position n and thus become the values used for points A and B such that $u'_1 = u'_A = 0.190$ and $v'_1 = v'_A = 0.447$ for point A in this example and $u'_n = u'_B = 0.186$ and $v'_n = v'_B = 0.432$ for point B in this example.

Hence $\Delta u'v' = \sqrt{0.000016 + 0.000225} = 0.01552$, which must be reported as 0.016.

Overall uncertainty

$\leq \pm 0.003$ in u' and v' .

See chapter 9

References

1. Flat Panel Display Measurements Standard, (FPDM), Version 2.0, VESA - Video Electronics Standards Association Display Metrology Committee. June 1, 2001, CA 95035, Milpitas.
2. Kokoschka S. (1986). Visibility aspects of VDUs in terms of contrast and luminance. Behaviour and information technology. vol.5, No. 4, pp 309-333.
3. Hunt, R.W.G. Measuring colour. 3rd edition (1998), Kingsley-Upon-Thames: Fountain Press.
4. CIE Publication 15.2 (1986), Colorimetry, p. 11, p.27-28 and p. 53-54, table 1.3).
5. Roberts, A., Eng, B., (1995) "A method for the calculation of tolerances for display primary chromaticity coordinates" Research and development Department, Technical Resources, The British Broadcasting Corporation.
6. Le Grand, Y. (1957). Light, colour and vision. Chapman and Hall, pp 278-279.
7. Fairchild M. D. (1995), "Considering the surround in device-independent colour imaging". www.cis.rit.edu/people/faculty/fairchild/PDFs/Bart.pdf
8. ISO TC130 WD 12646 p. 5 Section 4.7 Chromaticity and luminance of the white and black points and tracking.

5.6 Color uniformity – angular dependence

Background

The human visual system is very sensitive to changes in color hue in white and grey areas. White and gray color hues also serve as reference colors on the screen, that affect how all other colors are perceived. Patches of color variation on an active white or gray screen may reduce the contrast, be disturbing and affect readability, color rendering and color differentiation.

Definition

The white color uniformity – angular dependence of a display is the capability of the display to maintain constant white color over the screen surface depending of the direction from which the screen is viewed.

Applicability

Non monochromatic tablet computers with backlit or light emitting pixels.

5.6.1 Mandate

In landscape mode, the $\Delta u'v'$ between areas on the left side and the right side of the screen when it is positioned at $+30^\circ$ and at -30° horizontally to the screen normal (rotated around the vertical axis through the center of the screen) must be ≤ 0.024 .

The following is submitted to TCO Development:

- A copy of the test report(s), and a copy of the verification report(s) from a verifier approved by TCO Development.
 - The measured value must be reported in TCO Certified Portal.
-

5.6.2 Clarification

Preparations for testing

- All necessary preparations described in chapter 9 must be done.
- The screen background must be RGB 102,102,102.
- Chromaticity coordinates u' and v' must be measured at three different positions on the screen as shown in figure *color uniformity - angular dependence 1*. Each measurement position must consist of white RGB 255, 255, 255 areas with a size that is 4% of the active screen size.
- The spectro-radiometer must be positioned and directed orthogonally to the screen center-point as described in chapter 9.

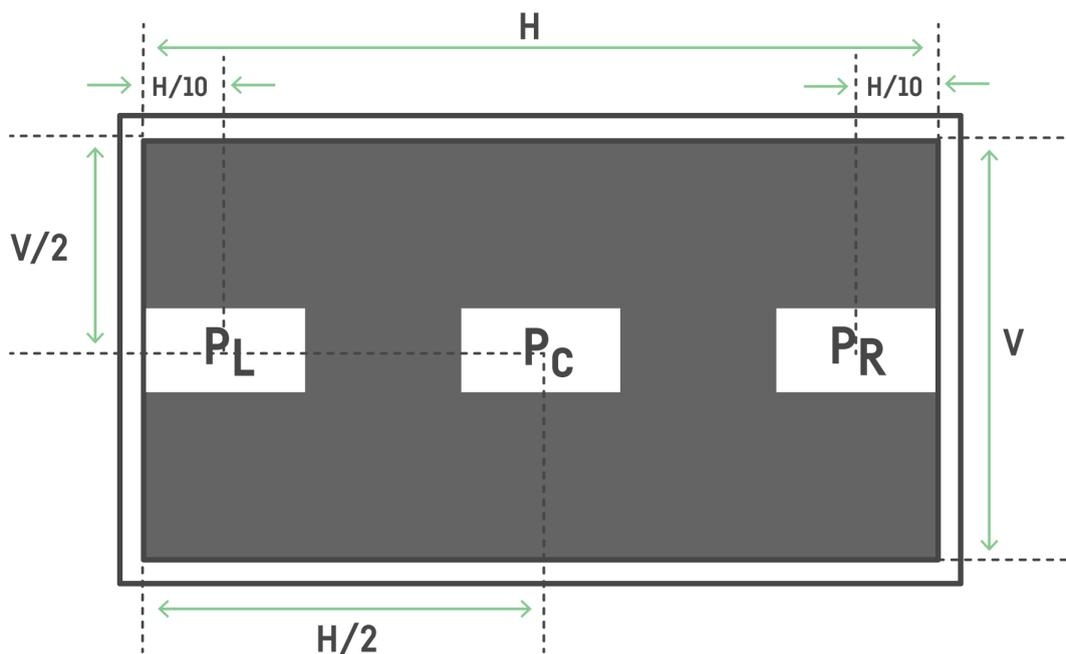

Figure *color uniformity - angular dependence 1*. Measurement positions for color uniformity-angular dependence.

Equipment

Spectro-radiometer with a capacity to present u' and v' coordinates with at least 3 decimals.

Test method

- The spectro-radiometer must always be directed towards a measurement point and rotated around a fixed vertical axis, (or horizontal axis for the tilt measurement) through the focal point of the front lens with a distance as described in chapter 9.
- The spectro-radiometer must be turned towards positions P_L and P_R and focused. The colour co-ordinates at positions P_L and P_R ($u'_{PL/0}$, $v'_{PL/0}$ and $u'_{PR/0}$, $v'_{PR/0}$ respectively) must be recorded.
- The screen must then be rotated $+30^\circ$ around a vertical axis through the screen centre-point and the chromaticity coordinates at positions P_L , P_R , ($u'_{PL/+30}$, $v'_{PL/+30}$ and $u'_{PR/+30}$, $v'_{PR/+30}$ respectively) must be recorded.
- The screen must finally be rotated -30° around a vertical axis through the screen centre-point and the chromaticity coordinates at positions P_L , P_R , ($u'_{PL/-30}$, $v'_{PL/-30}$ and $u'_{PR/-30}$, $v'_{PR/-30}$ respectively) must be recorded.

- Pivot screens must only be measured in the normal landscape mode.

Test evaluation

$\Delta u'v'$ according to the CIE (1976) uniform chromaticity scale diagram must be calculated for each measured position using the formula

$$\Delta u'v' = \sqrt{(u'_A - u'_B)^2 + (v'_A - v'_B)^2}$$

where A and B are the two points found to have the largest color difference between them. The largest difference in $u'v'$ value must be reported.

The result must be presented to 3 decimal places.

(The evaluation procedure is exemplified below)

- Make a table of chromaticity values for each measurement position and calculate $\Delta u'v'$ for +30° for and -30°.

Measurement position no.	Example value u'	Example value v'
PL /+30	0.190	0.447
PR /+30	0.187	0.442
Difference at +30°	0.003	0.005
$\Delta u'v'$ at +30°	0.0059	
Measurement position no.	Example value u'	Example value v'
PL /-30	0.182	0.436
PR /-30	0.189	0.432
Difference at -30°	0.007	0.004
$\Delta u'v'$ at -30°	0.0081	
Largest difference $\Delta u'v'$	0.0081 in this example	

The largest calculated $\Delta u'v'$ difference is 0.0081 when the screen is rotated -30°. The test value to be reported is this value, reported to 3 decimal places, thus 0.008.

Overall uncertainty

$\leq \pm 10\%$ in luminance.

$\leq \pm 0.003$ units for u' and v' .

$\leq \pm 0.3^\circ$ in rotation angle.

See chapter 9

References

1. Flat Panel Display Measurements Standard, (FPDM), Version 2.0, VESA - Video Electronics Standards Association Display Metrology Committee. June 1, 2001, CA 95035, Milpitas.

2. Kokoschka S. (1986). Visibility aspects of VDUs in terms of contrast and luminance. Behaviour and information technology. vol.5, No. 4, pp 309-333.
3. Hunt, R.W.G. Measuring colour. 3rd edition (1998), Kingsley-Upon-Thames: Fountain Press.
4. CIE Publication 15.2 (1986), Colorimetry, p. 11, p.27-28 and p. 53-54, table 1.3).
5. Roberts, A., Eng, B., (1995) "A method for the calculation of tolerances for display primary chromaticity coordinates" Research and development Department, Technical Resources, The British Broadcasting Corporation.
6. Le Grand, Y. (1957). Light, colour and vision. Chapman and Hall, pp 278-279.
7. Fairchild M. D. (1995), "Considering the surround in device-independent colour imaging". www.cis.rit.edu/people/faculty/fairchild/PDFs/Bart.pdf
8. ISO TC130 WD 12646 p. 5 Section 4.7 Chromaticity and luminance of the white and black points and tracking.

5.7 Color grayscale linearity

Background

A well-tuned color grayscale is the basis for good color rendering on the screen. This is measured via steps in a grayscale on the screen. To enable correct color interpretation, each grayscale step should have similar color hues. To avoid confusion for the user, only the luminance should vary.

Definition

Color grayscale linearity is the capability of the screen to maintain the same u',v' coordinates of a grayscale pattern at all grayscale levels. Only the luminance should change from one grayscale step to the next.

Applicability

Non monochromatic tablet computers with backlit or light emitting pixels.

5.7.1 Mandate

The $\Delta u'v' \leq$ the maximum allowed difference for each step according to table *color grayscale linearity 1*.

Table *color grayscale linearity 1*

Greyscale	Maximum $\Delta u'v'$ difference					
	255	225	195	165	135	105
255	0					
225	0,045	0				
195	0,045	0,045	0			
165	0,050	0,050	0,050	0		
135	0,055	0,055	0,050	0,050	0	
105	0,055	0,055	0,055	0,055	0,050	0

The following is submitted to TCO Development:

- A copy of the test report(s), and a copy of the verification report(s) from a verifier approved by TCO Development.
- The largest $\Delta u'v'$ measurement must be reported in TCO Certified Portal.

5.7.2 Clarification

Preparations for testing

- All necessary preparations described in chapter 9 must be done.
- A TCO Certified default test image, as shown in figure 9.1.7, must be used for this measurement.
- The measurement area must have a size that is 4% of the active screen size and have the following RGB settings: R=G=B= 255, 225, 195, 165, 135, 105, 75, 45.

Equipment

Spectroradiometer with a capacity to present u' and v' coordinates with at least 3 decimals.

Test method

The instrument must be directed orthogonally towards the different measurement areas centers at the measurement distance described in chapter 9. Measure the chromaticity coordinates at the center of the measuring area for each grayscale step specified above. Change the grayscale of the area for each measurement.

Test evaluation

The evaluation procedure is exemplified below:

- A spreadsheet is available on tcocertified.com, which will calculate the $\Delta u'v'$ differences between all the grayscale levels according to the equation:

$$\Delta u'v' = \sqrt{(u'_A - u'_B)^2 + (v'_A - v'_B)^2}$$

- Fill in the chromaticity values of u' and v' for each measured grayscale step into the corresponding cells of the spreadsheet.
- The table *color grayscale linearity 1* contains colored cells indicating difference requirements. The principle is that the darker the grayscale, the more difficult it is to see a color difference.
- Examples on how to use the table: By using the column 255 (grayscale 255) and go down to line 165 (grayscale 165) you find that the maximum allowed color difference $\Delta u'v'$ is 0.050 (orange cell). For the grayscales 225 and 105 the maximum allowed difference is 0.055 (blue cell).

Overall uncertainty

$\leq \pm 10\%$ in luminance.

$\leq \pm 0.003$ units for u' and v' .

See chapter 9

References

1. Flat Panel Display Measurements Standard, (FPDM), Version 2.0, VESA - Video Electronics Standards Association Display Metrology Committee. June 1, 2001, CA 95035, Milpitas.
2. Kokoschka S. (1986). Visibility aspects of VDUs in terms of contrast and luminance. Behaviour and information technology. vol.5, No. 4, pp 309-333.
3. Hunt, R.W.G. Measuring colour. 3rd edition (1998), Kingsley-Upon-Thames: Fountain Press.

4. CIE Publication 15.2 (1986), Colorimetry, p. 11, p.27-28 and p. 53-54, table 1.3).
5. Roberts, A., Eng, B., (1995) "A method for the calculation of tolerances for display primary chromaticity coordinates" Research and development Department, Technical Resources, The British Broadcasting Corporation.
6. Le Grand, Y. (1957). Light, colour and vision. Chapman and Hall, pp 278-279.
7. Fairchild M. D. (1995), "Considering the surround in device-independent colour imaging". www.cis.rit.edu/people/faculty/fairchild/PDFs/Bart.pdf
8. ISO TC130 WD 12646 p. 5 Section 4.7 Chromaticity and luminance of the white and black points and tracking.

5.8 Luminance level

Background

Poor screen luminance can lead to low contrast, poor readability and color discrimination, which may cause misinterpretations and eye strain. Therefore, it is important that the luminance levels can be set both high and low enough, with respect to the ambient lighting.

Definition

Luminance being emitted from a particular area is a measure of the luminous intensity per unit area of light travelling in a given direction and falls within a given solid angle.

The unit of luminance is candela per square meter (cd/m^2)

Applicability

Tablet computers with backlit or light emitting pixels.

References

5.3- 5.8.

5.8.1 Mandate

The maximum luminance must be $\geq 200 \text{ cd}/\text{m}^2$.

The following is submitted to TCO Development:

- A copy of the test report(s), and a copy of the verification report(s) from a verifier approved by TCO Development.
 - The maximum luminance must be reported in TCO Certified Portal
-

5.8.2 Clarification

Preparation of the tablet computer for testing

- All necessary preparations described in chapter 9 must be done.
- The product must be unplugged from mains before testing.
- The TCO Certified default test image with an 18-step grayscale as shown in Figure *Luminance level 1* must be used for luminance level measurement.

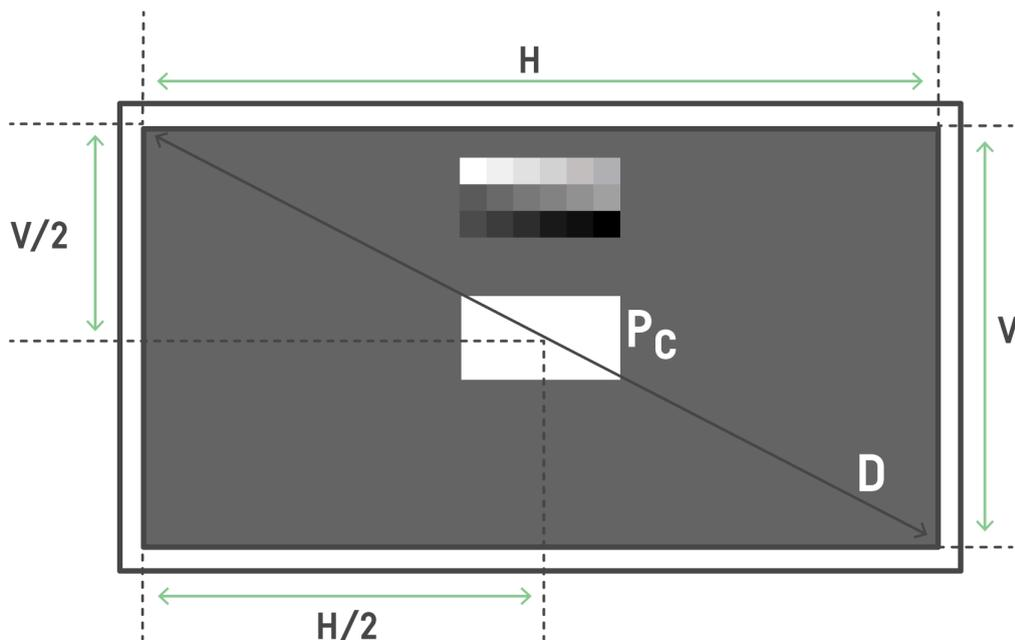

Figure *Luminance level 1*. The TCO Certified default test image with the 18-step grayscale inserted.

- The measurement position P_C must be at the center of the measurement area without line borders, having an RGB setting of 255, 255, 255, and positioned at the center of the screen. The background must be RGB 102,102,102.

The following evaluation must be carried out orthogonally to the screen surface

- To achieve the maximum luminance proceed as follows:
Use the TCO Certified default test image with an 18-step grey scale pattern presented on the screen. From the default setting, adjust the controls for the display to achieve as high luminance as possible with an acceptable image quality. The image quality is considered acceptable when at least 15 of the 18 grayscale steps are visible. At this maximum luminance, test that the display has a luminance $\geq 200 \text{ cd/m}^2$.
- When this test is completed, the display must be adjusted back to the test luminance setting as described under chapter 9 for all remaining Visual Ergonomic tests. Allow the display to stabilize before other test measurements are made.

Equipment

Luminance meter or spectroradiometer.

Test method

The luminance at the center of the white measurement area must be measured with the luminance meter directed orthogonally to the measurement area as described in chapter 9. For the battery mode measurement, the battery must be fully charged. Disconnect the power supply and wait five minutes to have the screen stabilized before the measurement of the luminance is performed. Re-connect the power supply after the Battery mode test is completed.

Test evaluation

The measured luminance is the required value. The luminance must be reported with no decimal places.

The measured Luminance, Contrast and Brightness settings must be noted in the test report. The preset CCT in default setting must also be noted.

Overall uncertainty

$\leq \pm 10$ % in luminance.

See chapter 9

References

1. CIE Publication 69 (1987), Methods of characterizing illuminance meters and luminance meters: performance characteristics and specifications.
2. Flat Panel Display Measurements Standard, (FPDM), Version 2.0, VESA - Video Electronics Standards Association Display Metrology Committee. June 1, 2001, CA 95035, Milpitas.
3. ISO 3664:1999. Viewing conditions for graphic technology and photography, p. 10 Monitor luminance.
4. Barten, P.G.J., (1999) Contrast sensitivity of the human eye and its effects on image quality, SPIE Optical Engineering Press p. 179.
5. Wyszecki, G., Stiles, W.S., (1982) Colour Science: Concepts and methods, quantitative data and formula, Second Edition, John Wiley & Sons, Inc. Chapter 7, Visual thresholds, pp 567-569.
6. Le Grand, Y. (1957). Light, colour and vision. Chapman and Hall, p. 119

5.9 Luminance uniformity

Background

When poor luminance uniformity is visible, it can locally affect the contrast and consequently the readability of information on the display. The areas of deviating luminance can have different sizes and cause varying contour sharpness.

Definition

Luminance uniformity is the capacity of the tablet display to maintain the same luminance level over the whole active screen area. The luminance uniformity is defined as the ratio of maximum to minimum luminance within the fully active screen area.

Applicability

Tablet computers with backlit or light emitting pixels.

5.9.1 Mandate

Luminance variation across the active screen, $L_{\max} : L_{\min}$ must be ≤ 1.50 .

The following is submitted to TCO Development:

- A copy of the test report(s), and a copy of the verification report(s) from a verifier approved by TCO Development.
- The Luminance variation must be reported in TCO Certified Portal

5.9.2 Clarification

Preparations for testing

- All necessary preparations described in chapter 9 must be done.
- The entire active area of the screen must be white and the display color setting must be RGB 255, 255, 255.

Equipment

Luminance meter or spectroradiometer.

Test method

The luminance must be measured orthogonally to the tablet screen plane at 9 points. The 4 corner positions (1, 3, 7 and 9) are measured 1° from the edges of the screen as shown in figure *luminance uniformity 1*. The 4 side positions (2, 4, 6 and 8) are measured on the middle of the side 1° from the edge. Finally the center position (5) is measured. This means that all measurement points have $1/2^\circ$ marginal to the edges if the measurement area of the instrument is 1° .

The luminance uniformity must also be evaluated visually by the technician in order to find any dark or bright areas except from the 9 default positions. If a significantly bright or dark

area is found these measuring points must also be measured and used to evaluate the luminance uniformity.

The conditions for luminance measurement in the corner positions and the distribution of other measurement points are illustrated in figure *luminance uniformity 1*.

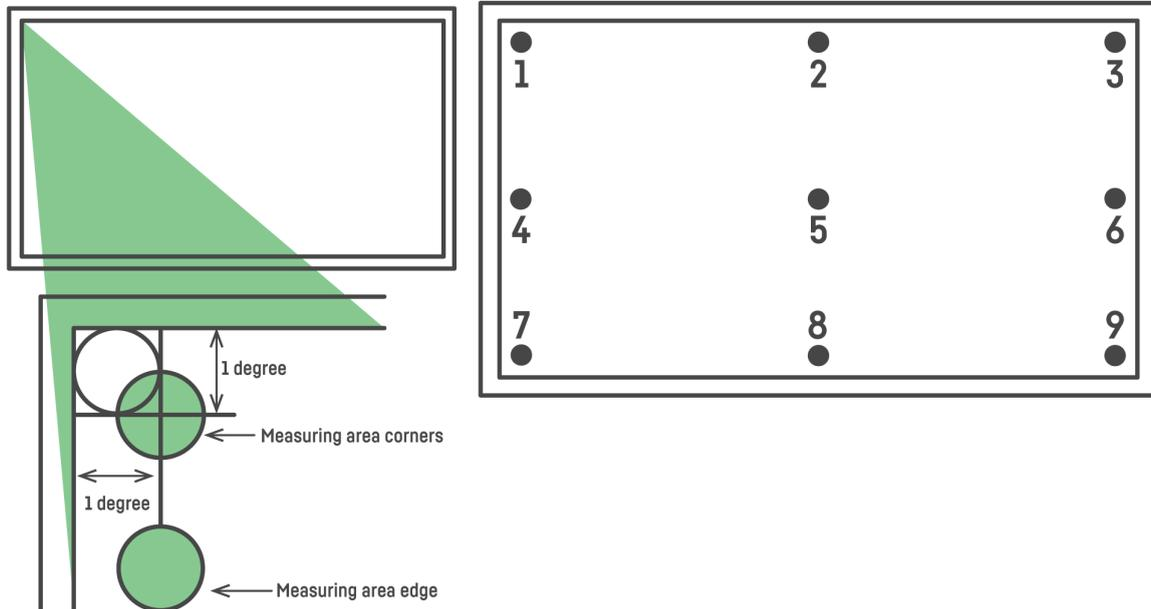

Figure *luminance uniformity 1*. Measurement positions for the measurement of luminance and color uniformity.

Test evaluation

The luminance uniformity must be reported as the ratio between the highest and the lowest measured luminance values. The result must be presented to 2 decimal places.

Overall uncertainty

$\leq \pm 10\%$ in luminance.

$\leq \pm 0.1$ unit in luminance uniformity.

See chapter 9

References.

1. CIE Publication 69 (1987), Methods of characterizing illuminance meters and luminance meters: performance characteristics and specifications.
2. Flat Panel Display Measurements Standard, (FPDM), Version 2.0, VESA - Video Electronics Standards Association Display Metrology Committee. June 1, 2001, CA 95035, Milpitas.
3. ISO 3664:1999. Viewing conditions for graphic technology and photography, p. 10 Monitor luminance.
4. Barten, P.G.J., (1999) Contrast sensitivity of the human eye and its effects on image quality, SPIE Optical Engineering Press p. 179.
5. Wyszecki, G., Stiles, W.S., (1982) Colour Science: Concepts and methods, quantitative data and formula, Second Edition, John Wiley & Sons, Inc. Chapter 7, Visual thresholds, pp 567-569.

6. ISO 3664:1999, Viewing conditions for graphic technology and photography, p. 9
Uniformity of screen luminance.
7. Barten, P.G.J., (1999) Contrast sensitivity of the human eye and its effects on image
quality, SPIE Optical Engineering Press p. 179 - 181
8. Le Grand, Y. (1957). Light, colour and vision. Chapman and Hall, Chapter 11,
Luminance difference thresholds, p. 261.
9. Le Grand, Y. (1957). Light, colour and vision. Chapman and Hall, Chapter 11,
Luminance difference thresholds.

5.10 Luminance uniformity - angular-dependence

Background

The luminance of a tablet display is angular-dependent, i.e. screen luminance decreases when the display is viewed slightly from the side, either horizontally or vertically. This can have a negative effect on contrast and can affect the readability of the display.

Definition

Luminance uniformity – angular dependence, is the capacity of the tablet display to maintain a certain luminance level independently of the viewing direction. The angular-dependent luminance uniformity is defined as the ratio of maximum luminance to minimum luminance in the specified measurement areas.

Applicability

Tablet computers with backlit or light emitting pixels.

5.10.1 Mandate

1. In landscape mode, when the screen is rotated around the vertical axis through the center of the screen the mean value of the L_{\max} to L_{\min} ratios at $\pm 30^\circ$ must be ≤ 3.00 .
2. In landscape mode, when the screen is rotated around the horizontal axis through the centre of the screen the mean value of the L_{\max} to L_{\min} ratios at $\pm 30^\circ$ must be ≤ 3.00 .

The following is submitted to TCO Development:

- A copy of the test report(s), and a copy of the verification report(s) from a verifier approved by TCO Development.

5.10.2 Clarification

Preparations for testing

- All necessary preparations described in chapter 9 must be done.
- Luminance values must be measured at five different positions on the screen as shown in figure *luminance uniformity - angular-dependence 1*. Each measurement position must consist of white RGB 255, 255, 255 measurement areas (4% of the active screen size) without line borders.
- The background must be RGB 102,102,102.
- The luminance meter must be positioned and directed orthogonally to the screen center-point as described in chapter 9.

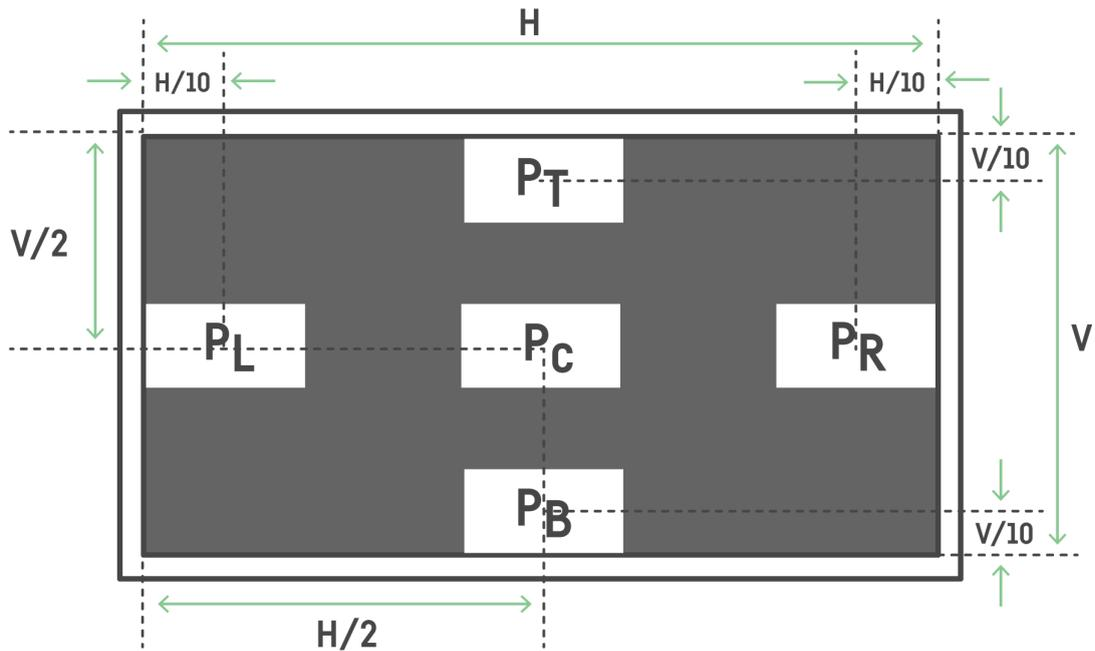

Figure: *luminance uniformity - angular-dependence 1*. Measurement positions for luminance uniformity - angular dependence.

Equipment

Luminance meter.

Test method

1. The luminance meter must always be directed towards a measurement point and rotated around a fixed vertical axis (or horizontal axis for the tilt measurements) through the focal point of its front lens at the distance described in chapter 9.
2. In landscape mode the display must be rotated +30 degrees around a vertical axis through the display center-point and the luminance at positions P_L and P_R , ($L_{P_L/+30/0}$ and $L_{P_R/+30/0}$ respectively) must be recorded. See figure *luminance uniformity - angular-dependence 2*.
3. In landscape mode the display must then be rotated -30 degrees around the vertical axis through the screen center-point and the luminance at positions P_L and P_R ($L_{P_L/-30/0}$ and $L_{P_R/-30/0}$ respectively) must be recorded. See figure *luminance uniformity - angular-dependence 2*.
4. In landscape mode the display must then be tilted +30 degrees backwards around a horizontal axis through the display center-point and the luminance at positions P_T and P_B ($L_{P_T/0/+30}$ and $L_{P_B/0/+30}$ respectively) must be measured. The result must be recorded. See figure *luminance uniformity - angular-dependence 3*.
5. In landscape mode the display must then be tilted -30 degrees around a horizontal axis through the display center-point and the luminance at positions P_T and P_B ($L_{P_T/0/-30}$ and $L_{P_B/0/-30}$ respectively) must be measured. The result must be recorded. See figure *luminance uniformity - angular-dependence 3*.
6. The measurements to be carried out are summarised in table *luminance uniformity - angular-dependence 4*. The step numbers in the step column are the test method paragraphs.

Table *luminance uniformity - angular-dependence 4*.

Steps	Landscape mode	Screen rotation	Screen tilt	Measuring points			
				P _L	P _R	P _T	P _B
Step 2	Horizontal direction (turned around vertical axis)	+30°	0°	X	X		
Step 3	Horizontal direction (turned around vertical axis)	-30°	0°	X	X		
Step 4	Backwards tilt = (turned around the horizontal axis)	0°	+30°			X	X
Step 5	Forwards tilt = (turned around the horizontal axis)	0°	-30°			X	X

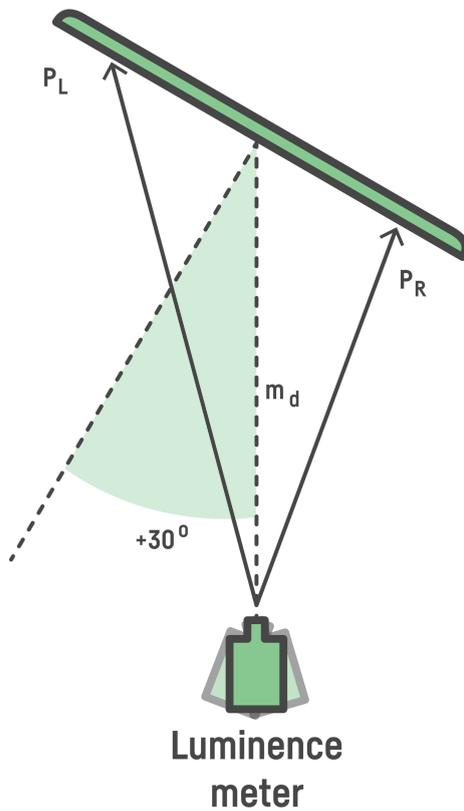

Figure *luminance uniformity - angular-dependence 2*. Top view of test set-up when the display is rotated ± 30 degrees. The + rotation is defined clockwise.

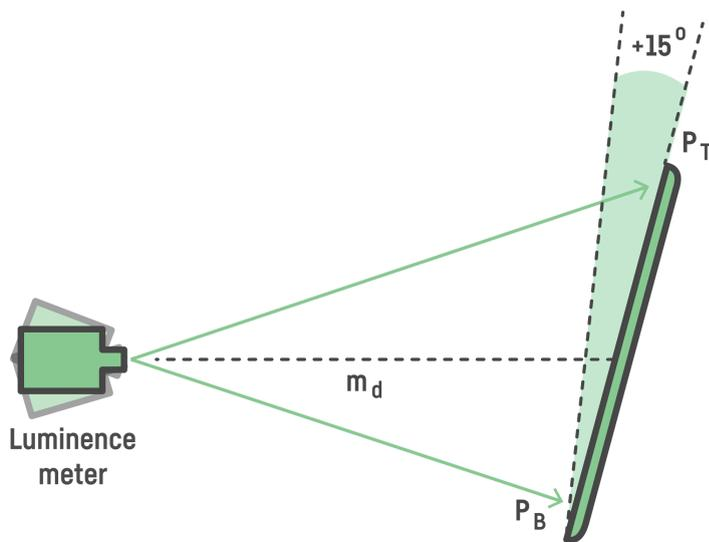

Figure *luminance uniformity - angular-dependence 3*. Side view of the test set-up when the display is tilted +15° backwards. The + tilt is defined backwards.

Test evaluation

- The luminance uniformity for angular dependence must be calculated as follows. In landscape mode, for the horizontal direction, (turned around the vertical axis) measurement presented in table *luminance uniformity - angular-dependence 4* (test step 2 and 3). A ratio between the two measured luminances must be calculated. This ratio, or its inverse if it has a higher value, must be reported as the requested L_{\max} to L_{\min} luminance uniformity in **mandate 1**. The requirement is on the mean value of the two ratios +30° and -30°. The result must be presented to 2 decimal places.
- In landscape mode, for the vertical direction (turned around the horizontal axis). Tilt backwards and tilt forwards $\pm 30^\circ$ (test steps 4 and 5 above). A ratio between the two measured luminances must be calculated. This ratio, or its inverse if it has a higher value, must be reported as the requested L_{\max} to L_{\min} luminance uniformity in **mandate 2**. The requirement is on the mean value of the two ratios +30° and -30°. The result shall be presented to 2 decimal places.

Both **mandate 1** and **mandate 2** results shall be presented in the test report.

Overall uncertainty

$\leq \pm 10\%$ in luminance.

$\leq \pm 0.3^\circ$ in rotation angle.

$\leq \pm 0.1$ unit in luminance uniformity.

See chapter 9

References

1. CIE Publication 69 (1987), Methods of characterizing illuminance meters and luminance meters: performance characteristics and specifications.

2. Wyszecki, G., Stiles, W.S., (1982) Colour Science: Concepts and methods, quantitative data and formula, Second Edition, John Wiley & Sons, Inc. Chapter 7, Visual thresholds, pp 567-569.
3. ISO 3664:1999, Viewing conditions for graphic technology and photography, p. 9 Uniformity of screen luminance.
4. Barten, P.G.J., (1999) Contrast sensitivity of the human eye and its effects on image quality, SPIE Optical Engineering Press p. 179 - 181
5. Le Grand, Y. (1957). Light, colour and vision. Chapman and Hall, Chapter 11, Luminance difference thresholds, p. 261.
6. Le Grand, Y. (1957). Light, colour and vision. Chapman and Hall, Chapter 11, Luminance difference thresholds.

5.11 Luminance contrast – characters

Background

The degree of contrast is important for readability and for distinguishing one character from another.

Definition

Luminance contrast – characters is the capacity of the display to maintain a high luminance difference between a bright background and dark characters or parts of characters over the whole active area.

Luminance contrast – characters is expressed as the ratio of the L_{\max} to L_{\min} difference over the sum of L_{\max} and L_{\min} , in accordance with Michaelson's formula.

Applicability

Tablet computers with backlit or light emitting pixels.

5.11.1 Mandate

The luminance contrast must be ≥ 0.70 measured orthogonally to the screen.

The following is submitted to TCO Development:

- A copy of the test report(s), and a copy of the verification report(s) from a verifier approved by TCO Development.
 - The luminance contrast must be reported in TCO Certified Portal
-

5.11.2 Clarification

Preparations for testing

- All necessary preparations described in chapter 9 must be done.
- A micro-photometer for luminance measurement must be aligned orthogonally to the display surface.
- The test images must be presented in a pixel matched way. One program that does this up to 8-bit color is Microsoft Paint.

Equipment

A micro-luminance meter such as an array photodetector capable of measuring luminance on structures ≤ 0.02 mm. Measurement requirements are given in chapter 9.

Test method - New

This measurement is a modified version of the measurements in IDMS 7.2 and IDMS 7.8. By visual evaluation of the standard test measurement position the technician must search for and locate visual stripes, or patches, that clearly influence the contrast of characters or even parts of characters. Once the patches are visually identified as having significantly lower contrast they must be geometrically referenced from the upper left corner of the active image and the position must be reported in the test report. If no such position is found, the default test position is the center of the screen. If one position is found that does not fulfil the mandate, there is no need to make further measurements.

With an array or scanning light measuring device, obtain the luminance profile of the vertical black-pixel line and the corresponding white region. Obtain the net signal S as a function of distance with any background subtracted (this is the background inherent in the detector if a nonzero signal exists for no light input). A correction for veiling glare must be made. See the figure below for an illustration of the pixel configuration and data. 12 consecutive pixel rows on the display must be used for integration in vertical direction to get a one-dimensional intensity signal.

Here, the 1-1-1-1 patterns must be used, i.e. the 6-groups with the highest resolution. Inside each group, the pattern with the worst measured performance must be chosen.

Perform a running window average (moving box-car filter) of the luminance profile where the averaging window width is as close as possible to the pixel pitch as rendered by the light measuring device. There should be at least 10 or more detector pixels per display pixel. For example, if an array detector is used and with the magnification of the imaging lens there are 53.4 array pixels which cover the display pixel pitch, then the running average window width is 53 array pixels wide.

From the resulting modulation curve determine (1) the net intensity level of the vertical black line

$S_k = S_d - S_g$, where S_d is the minimum intensity level (dim) of the black line generated by the display, S_g is the ground level, and (2) the net intensity level of the white line $S_w = S_h - S_g$, where S_h is the maximum intensity level (high) of the white line generated by the display.

Compute the resolution contrast ratio as, $C = (S_w - S_k) / (S_w + S_k)$.

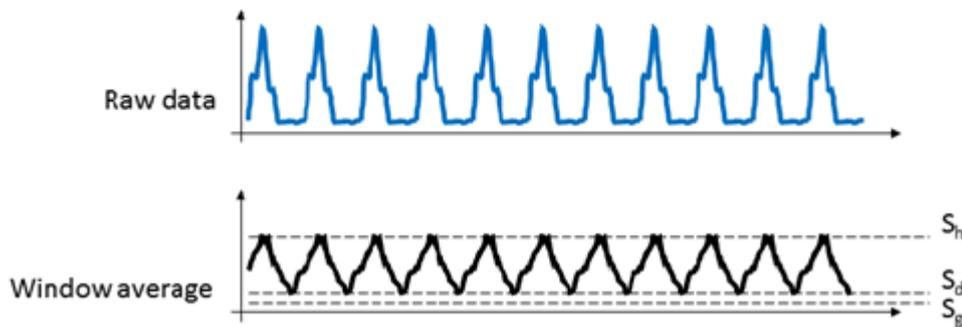
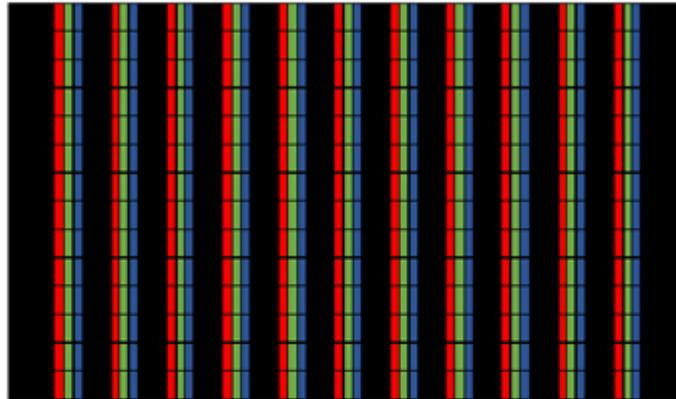

Figure *Luminance contrast - characters 1*: Measurement principle (from IDMS 7.2).

In summary:

$$S_k = S_d - S_g \quad (1)$$

$$S_w = S_h - S_g \quad (2)$$

$$C = (S_w - S_k) / (S_w + S_k)$$

Then perform the same operation but in vertical mode for the other set of grille patterns. Record the contrast values for both directions.

Test picture: "WGrille pattern" with the same resolution as the display.

Test evaluation

C must be ≥ 0.70 .

The lowest luminance contrast found must be reported.

The result must be presented to 2 decimal places.

Overall uncertainty

$\leq \pm 0.05$ in contrast.

The misalignment between the screen surface normal and the optical axis of the luminance meter must be $\leq 0.3^\circ$.

See chapter 9

References

1. Flat Panel Display Measurements Standard, (FPDM), Version 2.0, VESA - Video Electronics Standards Association Display Metrology Committee. June 1, 2001, CA 95035, Milpitas.

2. Wyszecki, G., Stiles, W.S., (1982) Colour Science: Concepts and methods, quantitative data and formula, Second Edition, John Wiley & Sons, Inc. Chapter 7, Visual thresholds, pp 567-569.
3. 5.09 ISO 3664:1999, Viewing conditions for graphic technology and photography, p. 9 Uniformity of screen luminance.
4. Barten, P.G.J., (1999) Contrast sensitivity of the human eye and its effects on image quality, SPIE Optical Engineering Press p. 179 - 181
5. Le Grand, Y. (1957). Light, colour and vision. Chapman and Hall, Chapter 11, Luminance difference thresholds, p. 261.
6. Kokoschka S. (1986). Visibility aspects of VDUs in terms of contrast and luminance. Behaviour and information technology. vol.5, No. 4, pp 309-333.
7. ISO 9241-4 1998 Ergonomic requirement for work with visual display terminals (VDTs) – Part 4: Keyboard requirements.(ISO 9241-4:1998/Cor 1:2000)

5.12 Luminance contrast – angular dependence

Background

For displays, the luminance and consequently the contrast of the display may be angular-dependent. The luminance variations can influence both the bright white and the dark areas of the screen, causing a change in contrast. This can have a negative effect on the readability of the display.

Definition

Luminance contrast – angular dependence, is the capability of the tablet display to maintain the same contrast regardless of the direction from which the screen is viewed. Luminance contrast – angular dependence, is expressed as the ratio of the L_{\max} to L_{\min} difference over the sum of L_{\max} and L_{\min} , in accordance with Michaelson's formula. It is measured at two different angles.

Applicability

Tablet computers with backlit or light emitting pixels.

5.12.1 Mandate

In landscape mode, the luminance contrast-angular dependence must be ≥ 0.80 at $\pm 30^\circ$ horizontally from the viewing direction (rotated around the vertical axis through the center of the screen).

The following is submitted to TCO Development:

- A copy of the test report(s), and a copy of the verification report(s) from a verifier approved by TCO Development.
- The luminance contrast-angular dependence must be reported in TCO Certified Portal.

5.12.2 Clarification

Preparations for testing

- All necessary preparations described in chapter 9 must be done.
- A TCO Certified default test image, as shown in figure 9.1.7, must be used for this measurement.
- The measurement area must have each of the following RGB settings: (RGB 255, 255, 255) and (RGB 0, 0, 0).

Equipment

Luminance meter or spectroradiometer.

Test method

- The luminance meter must be positioned and directed orthogonally to the screen center-point as described in chapter 9.
- The tablet computer display must be rotated around a vertical axis through the screen front center, changing the azimuth angle to + 30°. The luminance of the white measurement area L_{W+30} and the luminance when the measurement area is black L_{k+30} at the center must be recorded.
- Finally the azimuth angle of the screen must be changed to -30° and the new measurements $L_{W/-30}$ and $L_{k/-30}$ taken.

Test evaluation

The luminance contrast values C_{+30} and C_{-30} must be calculated using the formula

$$C = \frac{L_W - L_K}{L_W + L_K}$$

Of C_{+30} and C_{-30} , only the lowest value must be reported as the luminance contrast.

Overall uncertainty

$\leq \pm 10\%$ in luminance.

$\leq \pm 0.05$ in contrast.

See chapter 9

References

1. Flat Panel Display Measurements Standard, (FPDM), Version 2.0, VESA - Video Electronics Standards Association Display Metrology Committee. June 1, 2001, CA 95035, Milpitas.
2. ISO 3664:1999, Viewing conditions for graphic technology and photography, p. 9 Uniformity of screen luminance.
3. Le Grand, Y. (1957). Light, colour and vision. Chapman and Hall, Chapter 11, Luminance difference thresholds.
4. Kokoschka S. (1986). Visibility aspects of VDUs in terms of contrast and luminance. Behaviour and information technology. vol.5, No. 4, pp 309-333.
5. Wyszecki, G., Stiles, W.S., (1982) Colour Science: Concepts and methods, quantitative data and formula, Second Edition, John Wiley & Sons, Inc. Chapter 7, Visual thresholds, pp 574-575.

6 Product lifetime extension

- In our current, linear way of producing and consuming IT products, we take virgin natural resources and make products from them which we then discard once we're done using them – often after a relatively short time.
- Linearity leads to the loss of valuable and scarce natural resources, pollution and extensive energy use that contributes to the climate crisis.
- Moving toward sustainable solutions means creating a system that is more regenerative, where products and materials are kept in their intended use longer.

Linearity undermines ecosystems and the economy

Today, the common approach to the IT product life cycle is linear. Virgin materials are extracted to make new products which are used and then discarded, often after a relatively short time. In a majority of cases, materials are not recycled, and turn to waste. This linear “take, make, use, dispose” model is not sustainable and largely inefficient from a resource perspective. It depletes the earth's natural resources and creates enormous amounts of hazardous e-waste.

Our approach: driving the development of products that can live longer

The best way to begin taking a more circular approach to the production and consumption of IT products is to extend their usable life. For the IT industry, this means designing products that are durable, built to last, upgradeable and repairable, making them more attractive for reuse or secondary markets. Once a product has reached the end of its usable life, the materials should be possible to recycle and use again in new products.

Criteria in chapter 6 focus on:

- Extending product life by requiring that products are durable and repairable, and that spare parts and repair manuals are available.
- Making sure batteries in mobile products live longer, are replaceable and easily can be charged in a way that protects the battery from premature degradation.
- Enabling the reuse of cables and reducing e-waste through requirements of standardized connectors.
- Preventing data leakage and promoting safe reselling of products through secure data removal solutions.
- Introducing a reparability index for mobile devices which indicates how easy they are to maintain and repair.
- Enabling at least five years of supported product lifetime through an extended product warranty and free software and security updates.

6.1 Product warranty

Background

A precondition for an extended product lifetime is that the product is of high quality. A product warranty provides the brand owner with an economic incentive to design a durable product that lasts longer and to encourage users to keep their products longer before replacing them.

Definitions

Brand owner: The company or organization owning or controlling the brand name.

Brand name: The name or sign, including but not limited to a trademark or company name, used to identify, amongst users and customers, the manufacturer or seller of a product.

Product warranty: Covers defects existing at the time of delivery and those appearing after delivery that are due to material or manufacturing faults. It does not cover damages due to misuse or accidents.

MSRP: Manufacturer's suggested retail price

Applicability

All product categories.

6.1.1 Mandate

In all markets where the product is sold, the brand owner must:

- Offer a 5-year minimum available warranty, where at least 1 year must be included free of charge.
- Each year of warranty, which is not included free of charge, must be offered for a maximum of 15% of the MSRP of the product and must be available for purchase together with the product.

Submit the following to an approved verifier:

A link to a public commitment in English showing compliance with the mandate on the following aspects for the certified product:

- Minimum included product warranty in years
- Minimum purchasable extended warranty in years
- The maximum cost (in % of product cost MSRP) per year for the extended warranty

The following is submitted to TCO Development:

- A copy of the verification report(s) from a verifier approved by TCO Development.

The following is submitted to TCO Development and may be published:

- Minimum included product warranty in years
- Minimum purchasable extended warranty in years
- Minimum total available warranty in years (free + extended)
- The maximum cost (in % of product cost MSRP) per year for the extended warranty
- A link to a public commitment on warranty covering the certified product

6.1.2 Clarification

The brand owner must provide a link to a public statement in English covering the certified product, where the brand owner commits to the minimum warranties on any market where the product is sold. (The warranty statement may be in the user manual as long as it is under a headline called "Warranty" in the table of contents.) If the product is only sold in a non-English-speaking market, it is possible to provide the original statement to be translated and verified by the verifier. The verifier must be able to understand the language of the warranty statement and translate it into English.

If product components have different warranty periods, or if different warranty periods are offered in different regions, the worst-case scenario for the product (least number of years) must be used in the statement.

This commitment must also include the maximum cost of 15% of the MSRP of the warranty and information on how to purchase an extended warranty, for example, directly from the brand owner's webshops or through a retailer. If several years can be purchased at the same time, the total cost is divided by the extra years (in addition to the first year, which must be included free of charge). All available lengths of the plan must fulfill the criterion.

Example: MSRP = 1000EUR, gives warranty cost per year \leq 150 EUR

2 year warranty for 70 EUR gives 70EUR/ year.

3 year warranty for 200 EUR gives 100EUR/ year.

5 year warranty for 600 EUR gives 150EUR/ year.

The link to the public commitment on warranty covering the certified product must be functioning during the validity of the certificate. If the URL is changed, then it must first be approved by TCO certified, and the new URL must be added to the certificate.

The following concepts of warranty are used

- Minimum included product warranty: This is the minimum number of years (at least 1 year) of product warranty that is included for free on all markets where the product is sold.
- Minimum purchasable extended warranty: This is the minimum optional extension of the product warranty, offered for purchase with the product on all markets.
- Minimum total available warranty: This is the worst-case combination of "included product warranty" and "purchasable extended warranty" on any market where the product is sold.
- Maximum warranty cost per year (in % of product cost): This is the maximum annual cost for the purchasable extended warranty must not exceed 15% of the MSRP cost of the product.

6.2 Replaceable components

Background

Extending the lifetime of IT products is the most effective way to reduce their environmental impact. Components that often break or become outdated may limit the total lifespan of the product and must be replaceable. By providing the user with clear instructions on how to replace these critical components, IT-products can live longer.

Definitions

CPU: Central processing unit.

GPU: Graphics processing unit.

RAM: Random access memory.

Storage: Any computing hardware that is used for storing, porting, and extracting data files and objects, including temporary and permanent storage of information (SSD, HDD, RAM).

Display assembly: Main display panel.

All batteries: Defined as all batteries with one or more cells that are installed in the product.

System board: Also referred to as the motherboard.

Keyboard: Built-in keyboard.

External/Internal PSU: The power supply unit used to convert AC to low voltage DC power for the internal components of the product.

Critical, replaceable components: Components that are crucial for the functionality and have a high risk of failing during normal use. Components that are defined as critical, replaceable components (per product category) are listed in the clarifications section of this criterion.

Professional repairer: An individual or business who is engaged in the services of diagnosis, maintenance, or repair of digital electronic equipment and charges a fee for these services.

Applicability

All product categories.

6.2.1 Mandate

- The brand owner must provide a service manual describing how to replace at least all critical replaceable components. The service manual must be available for anyone to read, free of charge.

Submit the following to an approved verifier:

- A link to the service manual on the brand owner website or a pdf of the material that will be published there during the validity of the certificate

The following is submitted to TCO Development:

- A copy of the verification report(s) from a verifier approved by TCO Development, including the link and instructions on how to locate the service manual.

6.2.2 Clarification

Replaceable parts management

- The brand owner must provide a service manual including step-by-step instructions and component descriptions for the disassembly and assembly.
 - External PSU, charger, and AC Adapters are exempted from the disassembly instructions.
 - If instructions on how to replace all critical replaceable components (listed below) are included in the user manual, no additional service manual is needed to comply with the mandate 6.2.1.
- Board diagrams must be available for professional repairers free of charge.
- A critical, replaceable component must be possible to replace with an equivalent component. However, the replacement component does not have to be identical to the original component.
- Instructions on how to replace the critical components must be available online during the validity of the certificate.
- If a critical component is soldered, step-by-step instructions are not needed, however it must be stated that the component is soldered in the service- or user manual.
- Headband cushions which are molded do not need to be replaceable. Headband cushions designed to be snapped/mounted (for eg, with adhesive) shall be replaceable.

Critical replaceable components information:

The instructions on how to replace the critical replaceable components listed below must only be made available if they are included in the certified product.

Displays Connectivity cables Power cables External PSU System board/motherboard Display panel assembly	Tablets Battery Display Panel/display assembly External/internal PSU
All-in-one PCs CPU External/internal PSU Storage (SSD, HDD, ODD) System memory (RAM) System board/motherboard	Smartphones Battery Display Panel/display assembly Charger
Notebooks Battery Display Panel/display assembly Storage (SSD, HDD) System memory (RAM) External/internal PSU Keyboard System board/motherboard	Headsets Battery External/internal PSU Earloop Neckband Ear tips Ear cushions Microphone shield Headband
Desktops CPU GPU (PCIe) External/internal PSU Storage (SSD, HDD, ODD) System memory (RAM) System board/motherboard	Projectors The light source (except lasers) Filters External PSU

Component table

References

1. Tecchio, P., Ardente, F., Marwede, M., Christian, C., Dimitrova, G. and Mathieux, F., Analysis of material efficiency aspects of personal computers product group, EUR 28394 EN, Publications Office of the European Union, Luxembourg, 2018, ISBN 978-92-79-64943-1, doi:10.2788/89220, J
2. Ben Bridgens, Kersty Hobson, Debra Lilley, Jacquetta Lee, Janet L. Scott, Garrath T. Wilson, Closing the Loop on E-waste: A Multidisciplinary Perspective, Journal of Industrial Ecology, 2017

6.3 Standardized connectors

Background

By using one standardized interface (USB Type-C) for charging and data transfer, fewer cables need to be manufactured, and the reuse of chargers and data cables can increase. USB Type-C is also designed to be more robust and future-proof than the existing USB Type-A and Type-B. Therefore, using USB Type-C helps prevent problems with failing ports.

Definitions

USB Type-C: A 24-pin USB connector system with a horizontally symmetrical "reversible" connector based on the "Universal Serial Bus Type-C Cable and Connector Specification".

Applicability

Notebooks, desktops, AIOs, smartphones, tablets,

6.3.1 Mandate

The device must be equipped with at least one USB Type-C receptacle compatible with USB 3.1 Gen 1 or faster and that remains accessible and operational at all times.

Submit the following to an approved verifier:

- Necessary documentation describing and proving how the mandate is fulfilled

The following is submitted to TCO Development:

- A copy of the verification report(s) from a verifier approved by TCO Development.
-

6.3.2 Clarification

Products with no connectors are exempted from this criterion.

A product manual, including an exploded diagram of the device illustrating the types of connectors used, may be submitted as proof.

or

A technical specification document describing the USB type - C connector to be a 3.1 gen 1 or faster together with a picture of the port.

6.4 Product durability

Background

The military standard MIL-STD-810H and the International Electrotechnical Commission IEC 60068-2 include a series of endurance tests such as low and extreme temperature and drop tests. Products that meet these requirements can last longer and be reused to a larger extent.

Definitions

MIL-STD-810H: Environmental Engineering Considerations and Laboratory Tests, a United States military standard for product durability.

IEC 60068-2: A collection of methods for environmental testing of electronic equipment and products.

Applicability

Notebooks, smartphones and tablets.

6.4.1 Mandate

The product must be tested according to the MIL-STD-810H or IEC 60068-2 test procedure with the modified storage / operational temperature interval and duration as well as the drop test height according to the table below. The results will be reported on the certificate.

Test	Test conditions	Required level
Drop test	Drop height	≥ 45 cm
High temperature	Storage temperature for ≥ 48 h	≥ 60 °C
	Operational temperature for ≥ 4 h	≥ 40 °C
Low temperature	Storage temperature for ≥ 48 h	≤ -30 °C
	Operational temperature for ≥ 4 h	≤ -20 °C

Submit the following to an approved verifier:

- A copy of the test report(s) from a laboratory accredited according to ISO 17025.

The following is submitted to TCO Development:

- A copy of the verification report from a verifier approved by TCO Development.

The following is submitted to TCO Development and may be published:

- The results for drop, high- and low temperature test(s) must be reported in TCO Certified Portal.

6.4.2 Clarification

Assessment and verification

The applicant must provide test reports showing that the model has been tested and has met the functional performance requirements for durability. Testing must be carried out by a test facility accredited according to ISO 17025 and the test report must be verified by a verifier approved by TCO Development.

Products which have already been tested to the same or a stricter specification, will be accepted without the need to retest. The following methods are accepted.

For MIL-STD-810H the following methods apply

- Drop test: Method 516.8 - Shock (procedure IV)
- High temperature: Method 501.7 - Basic Hot (A2)
- Low temperature: Method 502.7 - Basic Cold (C1)

Unless it can be proved that the plastics or rubber material in the product is unaffected by the applied test-temperature (as mentioned in paragraph 5.19 Total High Temperature Exposure Duration and Method 502.6 - 2.3.2 Exposure Duration), the duration of the high temperature test (method 501.7 Basic Hot (A2)) and the low temperature test (Method 502.7 Basic Cold (C1)) must be at least 48h in storage and 4h in operation. If a stricter testing is applied, such as Cold (C2) or Severe Cold (C3) then the duration must be at least 4h in storage and 4h in operation.

For IEC 60068-2 the following methods apply

- Drop test: 60068-2-31:Ec
- High temperature: IEC 60068-2-2:B
- Low temperature: 60068-2-1:Ab/e.

Test evaluation

The product under test shall first be baseline tested for performance at 20 °C with a fully charged battery. All operation tests shall be started with a fully charged battery in the system. During the low temperature operational test, the product may be switched on at ≤ 0 °C.

After exposure to any of the three specified stress tests, the product should be able to:

1. Boot up and operate normally
 - Boot or resume should not exceed 50% greater time increase as a result of the test.
 - No noticeable operational faults when using standard software applications (Excel, Word etc).
 - No major damage to the product that does not allow for standard usage, e.g.,- opening/closing of the notebook display, usage of any critical buttons, non-functional display.
2. Not create hazards to end user
 - No case or display cracking or other sharp points created from failures that could injure a user.
 - No electrical component failures or access that could result in a user safety issue.

6.5 Battery longevity

Background

Short life cycles for IT products is a global problem connected to product design, user habits and end of life solutions. One important reason why portable IT products are discarded prematurely is that the battery loses its capacity over time and becomes too degraded to provide enough power for the product. The product experience could many times be improved by replacing the battery instead of buying a new product.

Definitions

Main battery: Unit that incorporates one or more cells and which is ready for use. It incorporates adequate housing and a terminal arrangement and may have electronic control devices (IEC 61960).

State of Health (SoH): Current full charge capacity (in mAh), expressed as a percentage of the design capacity (rated capacity).

Rated capacity: The specified capacity by the manufacturer.

Applicability

Battery-operated products

6.5.1 Mandate

- The main battery must be able to withstand a minimum of 300 charging cycles with at least 90% of the rated capacity according to IEC 61960-3:2017 or newer.

Submit the following to an approved verifier:

- A copy of the test report(s) from a laboratory accredited according to ISO 17025.

The following is submitted to TCO Development:

- The battery model name, technology, rated capacity, rated voltage, rated power and the tested number of charging cycles for all main batteries must be reported in TCO Certified Portal.
- A copy of a verification report from a verifier approved by TCO Development.

The following is submitted to TCO Development and may be published:

- The tested number of charging cycles with at least 90% of the rated capacity remaining.

6.5.2 Clarifications

If the battery is tested for more than 300 cycles it must either showcase >90% remaining state of health of the rated capacity at the final cycle, or at the 300th tested cycle.

References

1. (EU Directive 2012/19/EU) Available at:
<http://eur-lex.europa.eu/legal-content/EN/TXT/PDF/?uri=CELEX:32012L0019&from=EN>
2. Peter Keil, Simon F. Schuster, Jörn Wilhelm, Julian Travi, Andreas Hauser, Ralph C. Karl, and Andreas Jossen Calendar Aging of Lithium-Ion Batteries: I. Impact of the Graphite Anode on Capacity Fade Journal of the Electrochemical Society 2016 163: A1872-A1880.
3. http://batteryuniversity.com/learn/article/capacity_loss
4. http://batteryuniversity.com/learn/article/battery_definitions

6.6 Battery replaceability

Background

Batteries are consumables, often with a shorter life than the product they are installed in. To extend the total lifespan of the product, main batteries must be replaceable, so that products can be repaired and reused. Another concern that makes replaceability important is that the explosive cells of Lithium-ion batteries may pose a fire risk when shredded in the recycling process, causing a hazardous situation for recyclers.

Definitions

Main battery: Unit that incorporates one or more cells and which is ready for use. It incorporates adequate housing and a terminal arrangement and may have electronic control devices (IEC 61960).

Reuse: Reuse is the second step in the waste hierarchy: waste prevention, reuse, recycling, recovery of energy and safe disposal.

Recycle: The purpose of recycling is to recover materials from waste, for use in the production of new products by upcycling or downcycling. Recycled materials can also be used as a component in new raw materials.

Earbuds: Earbuds rest on the concha – the opening outside the ear canal

Earphones: Earphones – also known as in-ear headphones – are inserted in the ear canal

Tools are defined under the criterion “replaceable components”

Applicability

Battery-operated products.

6.6.1 Mandate

- The battery must be replaceable by the end-user with the use of commercially available tools or tools provided free of charge with the product. No proprietary tools, thermal energy, or solvents must be necessary to replace the battery.
- The battery replacement instructions must be available online for anyone to read, free of charge.
- The battery must be available for anyone to purchase during the validity of the certificate.

Submit the following to an approved verifier:

- Necessary documentation describing and proving how the mandate is fulfilled

The following is submitted to TCO Development:

- A copy of the verification report(s) from a verifier approved by TCO Development.

The following is submitted to TCO Development and may be published:

- The toolless battery replacement evaluation must be submitted to TCO Certified Portal.

6.6.2 Clarifications

Headsets products defined as earbuds and earphones are exempted from the battery replaceability mandate. "Replacing the battery" means to disassemble the product (if needed), exchange the battery with a new one and assemble the product to its original state.

Earphones and earbuds in which the battery is placed inside or over the concha are exempt from the battery replaceability mandate. "Replacing the battery" means disassembling the product (if needed), exchanging the battery with a new one and assembling the product to its original state.

Batteries fixed with adhesives are ok to use as long as they can be removed without using heat or solvents. This can be achieved either through the use of a fairly weak adhesive or through a stress-release adhesive using "pull tabs".

Verification guidelines

A user and/or service manual may be considered sufficient documentation to determine if the battery is replaceable by the end user.

Instructions on how to replace the battery may be available either as a webpage, downloadable document, video or similar online media.

A link to a brand owner web page where batteries are listed as spare parts.

Toolless battery replacement (Yes/No)

- **Yes:** The main battery is possible to replace by the user without tools.
- **No:** The main battery is not possible to replace by the user without tools.

Verification: The verifier must check if the main battery is possible to replace by the user without tools.

6.7 Battery information and protection

Background

While extending the life of IT products is key to lowering its environmental impact, mobile IT products are often replaced because the battery has lost its capacity to deliver enough power which limits the functionality of the product. Each charging cycle will degenerate the battery and reduce the battery's capacity to hold a charge. To slow down the degradation of the battery, battery protection software that lowers the maximum battery charge level to at least 80% can extend the total lifetime of the battery. It is also important that the user understands how the performance of the product changes as the battery degrades. When the user has access to this information they are better equipped to make decisions on when it is time to replace the battery instead of changing the whole product.

Definitions

Charge cycle: One charge cycle is completed when the battery is charged from 0% to 100% and then discharged back down to 0%. This could be performed by partially charging-discharging the battery multiple times on different State of Charge (SoC) levels as long as the total amount of charge-discharge percentage is approximately equal to the nominal capacity.

State of Health (SoH): Current full charge capacity (in mAh), expressed as a percentage of the design capacity (rated capacity).

State of Charge (SoC): The remaining battery capacity expressed as a percentage of full-charge capacity (SBS-IF, 1998).

Applicability

Notebooks, smartphones, tablets.

6.7.1 Mandate

1. The brand owner must provide battery protection software that can lower the maximum battery charge level (SoC) to 80% or less. It must be pre-installed on the product.
2. The brand owner must provide software pre-installed that can determine and monitor the following, and display the data for the user:
 - State of Health
 - State of Charge
 - The number of full charge cycles that the battery has gone through.

Submit the following to an approved verifier:

- Necessary documentation describing and proving how the mandate is fulfilled

The following is submitted to TCO Development:

A copy of the verification report(s) from a verifier approved by TCO Development.

6.7.2 Clarification

The brand owner must specify the name and version of the software(s) used in part 1 and 2 of the mandate.

Chrome OS products are excluded from point 1 in this mandate.

In part 2 of the mandate, The “State of Health” and “The number of full charge cycles that the battery has gone through” are not applicable if the battery is replaceable by the user without tools.

6.8 Secure data removal

Background

By reusing IT products, their usable life can be extended which is an effective way of reducing their environmental impact. However, fear of confidential data leakage often prevents companies and individuals from making their products available on the second-hand market. By providing software that wipes the storage of the device, the owner can more safely recirculate their product.

Definitions

Brand owner: The company or organization owning or controlling the brand name.

Brand name: The name or sign, including but not limited to a trademark or company name, used to identify, amongst users and customers, the manufacturer or seller of a product.

Media sanitization: refers to a process that renders access to target data on the media infeasible for a given level of effort.

Applicability

Notebooks, network equipment, desktops, all-in-one PCs, servers, data storage products, smartphones and tablets.

6.8.1 Mandate

The brand owner must provide a free-of-charge media sanitization solution for the product, including instructions on how it is used.

Submit the following to an approved verifier:

Necessary documentation describing and proving how the mandate is fulfilled:

- How the media sanitization solution is distributed and that it conforms with “Clear” according to IEEE P2883.
or
- Proof that approved data encryption technologies are pre-installed.

The following is submitted to TCO Development:

- A copy of the verification report from a verifier approved by TCO Development.
-

6.8.2 Clarification

The brand owner must provide a media sanitization solution for the product, in one of the following ways:

1. Pre-installing it on/in the product before it is shipped.
2. Providing the software for download on their webpage, free of charge.
3. Providing a direct link on their own webpage to an external webpage where the software is available for download, free of charge.
4. Providing a remote secure data removal service upon request, free of charge.
5. Providing an on-site secure data removal service upon request, free of charge.

The selected media sanitization solution above must conform with the method of "Clear" in IEEE P2883 or ISO/IEC 27040:2024. Users must be able to use it at least once, free of charge.

OR

6. Pre-installed data encryption technologies that allow for erasure or removal of the encryption keys.

Instructions on how to use this functionality, the techniques used and the secure data deletion standard(s) it supports must be provided in the user manual and/or by a web link to the manufacturer's webpage.

Pre-installed data encryption technologies must have a security stronger or equal to: AES encryption algorithm in cipher block chaining (CBC) or XTS mode with a 128-bit or 256-bit key.

6.9 Standardized external power supply compatibility

Background

Today, cables and chargers are manufactured to many different standards, which makes them difficult to reuse. By using one standardized interface (USB Type-C) for wired charging and one standard (Qi) for wireless charging, fewer cables and chargers need to be manufactured and the re-use of chargers and data cables can increase.

Definitions

USB Type-C: A 24-pin USB connector system with a horizontally symmetrical "reversible" connector based on the "Universal Serial Bus Type-C Cable and Connector Specification".

EPS: External Power Supply

Applicability

All products with rechargeable batteries and external power supplies ≤ 240 W.

6.9.1 Mandate

- A. The product must carry a USB Type-C standardized receptacle (port) for USB Power Delivery according to the standard EN/IEC 63002:2021 - Identification and communication interoperability method for external power supplies used with portable computing devices or newer.

OR

- B. The product must have a built-in wireless charging capability that complies with Qi Wireless Power Transfer System, Power Class 0 Specification version 1.2.4, or future revisions.

Submit the following to an approved verifier:

- Necessary documentation describing and proving how the mandate is fulfilled

The following is submitted to TCO Development:

- A copy of the verification report(s) from a verifier approved by TCO Development.

6.9.2 Clarification

Interoperability guidelines for external power supplies are defined according to the IEC 63002:2021 or newer (Identification and communication interoperability method for external power supplies used with portable computing devices.)

For products delivered with a charging case, the case must fulfill the criterion.

6.10 Repairability index

Background

In order to make IT products more sustainable and avoid early disposal and E-waste, it is important that they are designed for easy repair, with easily accessible parts, clear guidelines, and a supply of replacement components. A repairability index provides stakeholders with a comprehensive assessment of a product's repairability. It is our ambition to align with global standards and regulations when possible, such as the EU Lot 3 mandate on repairability. Therefore this mandate may be revised when new EU regulations covering this come into force in the future.

Applicability

Smartphones, Tablets, Notebooks

6.10.1 Mandate

The repairability index of the product must be evaluated.

Submit the following to an approved verifier:

Necessary documentation describing and proving how the mandate is fulfilled:

- Disassembly depth for all listed parts
- Fasteners (type)
- Tools (type)
- Spare Parts availability
- Repair Information
- Spare Parts (duration)

The following is submitted to TCO Development:

- A completed "repairability index calculator" spreadsheet from a verifier approved by TCO Development.

The following is submitted to TCO Development and may be published:

- The calculated repairability index must be submitted to TCO Certified Portal

6.10.2 Clarifications

The repairability index must be calculated according to EU COMMISSION DELEGATED REGULATION (EU) 2023/1669 of 16 June 2023 or a more recent version. Notebooks are treated as tablets except for the critical components which are listed in this mandate. TCO Development provides a downloadable excel on their website to simplify this calculation.

The Repairability Index is an aggregated and normalized score, as a calculated value derived from the following six scoring parameters:

- Disassembly Depth.
- Fasteners (type).
- Tools (type).

- Spare Parts.
- Software Updates (duration).
- Repair Information.

The “Disassembly Depth”, “Fasteners (type)” and “Tools (type)” scores are based on the aggregation of the following priority parts:

Mobile phones and Tablets.

- Battery.
- Display assembly.
- Back cover or back cover assembly.
- Front-facing camera assembly.
- Rear-facing camera assembly.
- External charging port.
- Mechanical button.
- Main microphone(s).
- Speaker.
- Hinge assembly or the mechanical display folding mechanism.

Notebooks

- Battery (if multiple, consider deepest)
- Display assembly (if multiple, consider deepest)
- Keyboard
- Storage (SSD,HDD) (if multiple, consider deepest)
- System memory (RAM) (if multiple, consider deepest)
- Ports (Vga, Hdmi, USB,)
- Enclosure of entry (depending on the device, the point of entry to service internal parts differs)
- Systemboard/motherboard
- Fans

If any of the priority parts listed above is present in a product more than once, only the one that delivers the lowest score shall be considered in the calculation of the “Disassembly Depth”, “Fasteners (type)” and “Tools (type)” scores. If a priority part is not present in the product, the highest point level for each score shall be considered for this part.

Disassembly Depth (DD) assessment at part level

The Disassembly Depth score for each priority part shall be calculated based on the number of steps required to remove a part from a product, without damaging the product. The counting of the steps for each part starts from the product fully assembled, with the charger disconnected and any SIM card installed. Points ranging from 1 to 5 are assigned as follows:

- $DD \leq 2$ steps = 5 pt.
- 5 steps $\geq DD > 2$ steps = 4 pt.
- 10 steps $\geq DD > 5$ steps = 3 pt.
- 15 steps $\geq DD > 10$ steps = 2 pt.
- $DD > 15$ steps = 1 pt.

Definition of step: 'step' means an operation that finishes with the removal of a part (or bundle) or with a change of tool; any placement of a part away from its initial location, even if that entails partial disconnection or unplugging, shall also be considered as removal.

For the calculation of disassembly steps, the following rules shall apply:

- The disassembly depth count is completed when the target part is separated and individually accessible.
- Where multiple tools need to be used simultaneously, the use of each tool counts as a separate step.
- Operations related to cleaning, removing traces or heating are counted as steps.
- The disassembly depth shall be calculated on the basis of the repair and maintenance information, and of the description of the disassembly steps for each priority part given in the technical documentation;
- where remote notification or authorization of serial numbers or parts pairing is necessary for the full functionality of the spare part with the device, each of these actions is counted as five additional disassembly steps.
- software preparation steps do not count as steps for disassembly. (for example, shut down the battery in bios before disassembly = 0 steps added).

Fasteners (type) (F) assessment at part level:

The "Fasteners (type)" scores for each priority part are assigned according to the level of removability and reusability of the fasteners used in the device assembly. Points ranging from 1 to 5 are assigned as follows:

- Reusable Fasteners = 5 pt.
- Resupplied Fasteners = 3pt.
- Removable Fasteners =1 pt.
- Non removable fasteners = 0pt

Soldered fasteners are considered to be non-removable fasteners.

The assessment of the type of fasteners is based on the disassembly process to remove the specific priority part, starting from the previous priority part in disassembly sequence already removed. In case different types of fasteners are encountered in the disassembly of a priority part, the worst score shall be considered. The Fi scores shall be calculated on the basis of the repair and maintenance information, and of the description of the fasteners for each priority part given in the technical documentation.

Tools (type) (T) assessment at part level

The "Tools (type)" scores for each priority part i are assigned according to the complexity and availability of the tools needed for its replacement. Points ranging from 1 to 5 are assigned as follows for Storage, System memory (RAM), Ports, Enclosure of entry, Systemboard/motherboard, Fans:

- No tools = 5 pt;
- Basic tools = 4pt.

- A set of tools that is supplied (or offered to be supplied at no additional cost) with the spare part = 3 pt.
- A set of tools that is supplied (or offered to be supplied at no additional cost) with the product = 2 pt.
- Commercially available tools =1pt.

For Battery, Display assembly and Keyboard the points are assigned as follows:

- Tools supplied with product/part = 1pt
- Basic tools = 3 pt
- No tools = 5 pt

Tools Definitions from standard EN 45554:

basic tools - means a screwdriver for slotted heads, a screwdriver for cross recess screws, a screwdriver for hexalobular recess heads, a hexagon socket key, a combination wrench, combination pliers, combination pliers for wire stripping and terminal crimping, half round nose pliers, diagonal cutters, multi grip pliers, locking pliers, a prying lever, tweezers, magnifying glass, a spudger and a pick;

commercially available tool - means a tool that is available for purchase by the general public and is neither basic tools nor a proprietary tool;

The assessment of the type of tools is based on the disassembly process to remove the specific priority part, starting from the previous priority part in disassembly sequence already removed. Where different types of tools are needed for the disassembly of a priority part, the lowest score shall be considered. The Ti scores shall be calculated on the basis of the repair and maintenance information, and of the description of the tools for each priority part given in the technical documentation.

Spare parts availability (target group) score for smartphones and tablets shall be:

The "Spare Parts" score shall be calculated at product level as follows:

- Spare parts for all priority parts are available to end users and professional repairers = 5 pt;
- Spare parts for display assembly, battery, Enclosure of entry and cameras are available to end users and professional repairers; spare parts for all other parts are available to professional repairers = 4 pt;
- Spare parts for display assembly, battery and Back cover or back cover assembly are available to end users and professional repairers; spare parts for all other parts are available to professional repairers = 3 pt;
- Spare parts for display assembly and battery are available to end users and professional repairers; spare parts for all other parts are available to professional repairers = 2 pt;
- Spare parts for display assembly are available to end users and professional repairers; spare parts for all other parts are available to professional repairers = 1 pt;
- Spare parts for the hinge assembly, mechanical display folding mechanism are to be available only in case of foldable smartphones.

Spare parts availability (target group) score for Notebooks shall be:

- Battery and Display assembly to end users All other to professionals = 1pt
- Battery, Display assembly & Keyboard to end users; All other to professionals = 2pt
- Battery, Display assembly & Keyboard,Storage & Ram to end users; All other to professionals = 3pt
- Battery, Display assembly & Keyboard,Storage, Ram, Ports & Enclosure of entry to end users; All other to professionals = 4pt
- All parts available to end users = 5pt

Software updates (smartphones and tablets).

The ‘Software Updates (duration) score shall be calculated at product level as follows:

- Minimum guaranteed availability of security updates, corrective updates and functionality updates to the operating system for at least 7 years = 5 pt.
- Minimum guaranteed availability of security updates, corrective updates and functionality updates to the operating system for 6 years = 3 pt.
- Minimum guaranteed availability of security updates, corrective updates and functionality updates to the operating system for 5 years = 1 pt.

The above durations refer to years from the date of end of placement on the market of the product model.

Spare parts (duration)

The “Spare parts (duration)” score shall be calculated through the different spare parts levels bundled as follows:

Level 1 (most critical components): Battery, Display assembly

Level 2: Keyboard, Storage, System memory (RAM)

Level 3 (least critical components): Ports, Enclosure of entry, Systemboard/motherboard, Fans

	Level 1	Level 2	Level 3	Points
	Battery, Display assembly	Keyboard, Storage, System memory (RAM)	Enclosure of entry, Ports, Systemboard/motherboard, Fans	
Years	less than 7	less than 7	less than 7	0
Years	7	-	-	1
Years	7	7	7	2
Years	8	8	7	3
Years	9	9	8	4
Years	10	10	9	5

The above durations refer to years from the date of end of placement on the market of the product model.

Repair Information

Definition of repair and maintenance information according to COMMISSION REGULATION (EU) 2023/1670 of 16 June 2023:

The repair and maintenance information shall contain the level of detail needed to be able to identify and replace all priority parts for smartphones, tablets and notebooks and shall at least include:

Replace part information

1. the unequivocal product identification
2. a disassembly map or exploded view;
3. technical manual of instructions for repair, including marking of the individual steps;
4. a list of necessary repair equipment;

Identify faulty part information

5. wiring and connection diagrams, as required for failure analysis;
6. electronic board diagrams;
7. a list of necessary test equipment;
8. diagnostic fault and error information (including manufacturer-specific codes, where applicable);
9. component and diagnosis information (such as minimum and maximum theoretical values for measurements);
10. instructions for software and firmware (including reset software);
11. information on how to access data records of reported failure incidents stored on the device, where applicable, with the exception of personal identifiable information such as related to user behavior and location information;

The Repair Information score shall be calculated at product level as follows:

- Public availability of repair and maintenance information,
 - except electronic board diagrams, at no cost for end users and availability of repair and maintenance information,
 - including electronic board diagrams, at no cost for professional repairers = 5 pt.
- Availability of repair and maintenance information at no cost for professional repairers = 3 pt.
- Availability of repair and maintenance information with a reasonable and proportionate fee for professional repairers = 1 pt.
- A fee shall be considered reasonable if it does not discourage access by failing to take into account the extent to which the professional repairer uses the information.

The repairability index excel can be found in [Certification documents](#)

6.11 Security and functionality software updates

Background

Devices may become obsolete or vulnerable due to infrequent software updates, putting user data at risk and curtailing device longevity. Therefore TCO Certified intends to address the following challenges:

- Consumer Protection: Consistent security updates minimize risks from cyber threats and unauthorized data access.
- Device Longevity: By ensuring functionality updates, devices remain relevant longer, delivering better value to users and reducing electronic waste.
- Holding Manufacturers Accountable: This enforces a set support duration, nudging manufacturers towards more sustainable designs and post-sale maintenance.

Definitions

- Security update: A software update, including security patches, if relevant for a given device, whose main purpose is to provide enhanced security for the device.
- Corrective update: A software update, including corrective patches, whose purpose is to provide corrections to bugs, or malfunctions in the operating system.
- "The date of end of placement on the market": is defined as the later date of either when the product was marketed by the brand owner or when it was last manufactured.

Applicability

All product categories

6.11.1 Mandate

The brand owner must publicly ensure the availability of free-of-charge security and corrective software updates necessary to retain the initial functionality of the product for at least five years after the end of placement of the product on the market.

Submit the following to an approved verifier:

Documented proof of compliance with the mandate, including at least:

- A link to a public statement where the brand ensures the availability of these updates.
- The number of years after the end of placement of the product on the market, the brand owner publicly committed to delivering such updates.

The following is submitted to TCO Development:

- A copy of the verification report(s) from a verifier approved by TCO Development.

The following is submitted to TCO Development and may be published:

- A link to a public statement where the brand ensures the availability of these updates.
- The number of years after the end of placement of the product on the market, the brand owner publicly committed to delivering such updates.

6.11.2 Clarification

Verification guideline

The brand owner must provide a link to a public statement in English where the brand owner ensures the availability of free-of-charge security and corrective software updates necessary to retain the initial functionality of the product for at least five years after the end of placement of the product on the market.

For generic operating systems developed by third-party vendors (e.g. Microsoft, Google, etc.), the product's brand owner must instead ensure in the public statement that, at the time of certification, the third-party operating system vendor is committed to providing updates free of charge and that any announced minimum hardware requirements needed to continue receiving these updates are met (e.g if the existing operating system ceases to be supported and a new version must be installed).

The statement must include information on how these updates will be provided. The link must be functioning during the validity of the certificate. (The software update statement may be in the user manual as long as it is under a headline called "Software updates" in the table of contents.)

7 Reduction of hazardous substances

- Hazardous substances used in IT products risk human health and the natural environment.
- Legislation is lagging and focuses on banning substances, but the substitutions can be just as hazardous or even worse.
- TCO Certified drives transparency and knowledge-sharing, developing pathways to safer alternatives.

Hazardous substances – a risk to human health and the environment

No one knows how many chemicals are in use today. What we do know is that very few of these substances have been studied for their impact on humans and the environment. Examples of potentially hazardous substances are plasticizers, flame retardants and stabilizers, often used in components, cables and other plastic parts. These substances risk leaking out in the natural environment, both in connection with manufacturing, and when products and their packaging are incinerated, placed in landfill or recycled in an improper way.

Keeping hazardous substances out of products is also important from a circular perspective. Contaminated materials cannot be responsibly recycled and reused in new products and risk therefore being incinerated or discarded, adding to the enormous e-waste problem.

Our approach: guiding the IT industry to safer alternatives

For a long time, TCO Certified has restricted the use of harmful substances with criteria that go beyond RoHS. However, simply banning substances isn't enough. A banned substance may be replaced with another that is equally harmful or potentially even worse. Therefore, we need better information about substances before they are being used. With TCO Certified, a chemical is considered a high risk until it is proven to be otherwise. GreenScreen® for Safer Chemicals is used to identify a pathway to safer alternatives.

Criteria in chapter 7 focus on:

- Reducing or eliminating the use of hazardous substances in IT products and their packaging beyond RoHS.
- Requiring that all flame retardants, plasticizers and stabilizers are assessed by an independent toxicologist and benchmarked as a safer alternative for use in certified products. The same principle applies also to process chemicals, covered in chapter 2.
- Increasing transparency and making safer alternatives the mainstream choice by collecting all approved substances on the public TCO Certified Accepted Substance List.

7.1 Heavy metals

Background

Electronic devices contain hazardous substances like heavy metals and brominated flame retardants. The effects of cadmium, mercury, lead and hexavalent chromium are well documented as substances hazardous both to human health and the environment. They may cause problems, both in the manufacturing phase where workers or the environment can be exposed, and at the material recovery, where uncontrolled recycling can cause the release of toxins such as dioxins and furans.

This criterion is harmonized with EU RoHS Directive (2011/65/EU), except that in TCO Certified, mercury is not allowed in lamps. As TCO Certified is a global certification, this also affects products sold outside the EU.

Applicability

All product categories.

7.1.1 Mandate

The product must not contain the RoHS substances cadmium, mercury, lead and hexavalent chromium.

Submit the following to an approved verifier:

- The worst-case concentrations by weight in homogeneous materials and the worst-case concentration in batteries for cadmium, mercury, lead and hexavalent chromium must be provided.

The following is submitted to TCO Development:

- A copy of a verification report from a verifier approved by TCO Development.
-

7.1.2 Clarification

The worst-case concentration report must be signed by the brand owner and may cover several products.

Exemptions are according to EU Directive 2011/65/EU (RoHS) and the documents supporting the directive, except that mercury in lamps is not permitted.

The maximum concentration values tolerated by weight in homogeneous materials are 0.01% for cadmium, 0.1% for mercury, 0.1% for lead and 0.1% for hexavalent chromium according to EU RoHS Directive (2011/65/EU annex II) and the documents supporting the directive.

The limit value for batteries is 0.0005 % for mercury, 0.002 % for cadmium and 0.004 % lead per listed part, according to Regulation (EU) 2023/1542.

References

1. Regulation 2023/1542 concerning batteries and waste batteries.
2. EU Directive 2011/65/EU restriction of EEE hazardous substances.

7.2 Halogens

Background

Halogenated substances are often persistent and can bio-accumulate in living organisms. They are problematic from both a human health and environmental perspective throughout the product life cycle and should be phased out. Workers may be exposed during manufacturing. Substances risk leaking out into the natural environment at end of life. PVC is by far the most common halogen-containing plastic.

Definitions

An electronic component is considered an individual part or combination of parts that, when together, perform a design function(s) and are typically directly attached to a printed circuit board. Internal and external power supplies are not included in the definition.

Product housing protects internal components and safeguards the user against injury from these electrical components. Product safety standards define these safeguards as different types of protective enclosures. These enclosures are added to safeguard against electrical shock, high temperatures, fire and mechanical (moving parts such as the fan), and radiation (such as any internal laser), whilst also protecting internal parts.

Printed circuit board (PCB) or printed wiring board (PWB) laminate is a printed board that provides point-to-point connections.

Power board or power PCB regulates the power leading to the device, converting alternating current to direct current

Polybrominated biphenyls (PBB) and polybrominated diphenyl ethers (PBDE) are restricted in the EU RoHS Directive (2011/65/EU) due to the hazardous properties of these substances.

Hexabromocyclododecane (HBCDD) has been identified as a substance of very high concern in accordance with EU REACH criteria due to PBT (persistent, bio-accumulative, toxic) properties.

External cables delivered with the product: Cables that provide power to the product and cables that connect the product to an external peripheral (USB-USB, HDMI-HDMI, HDMI-DP, VGA-VGA, etc).

Applicability

All product categories.

7.2.1 Mandate

1. Product housing, printed circuit board (PCB) laminates, and external cable parts above 0.5 grams must not contain intentionally added (additive or reactive) halogenated flame retardant, plasticizer or vinyl polymer stabilizer substances.

Exempted are all other parts, such as electronic components and PCB laminates sealed inside electronic components.

2. The product must not contain PBB, PBDE and HBCDD. No parts of the product are exempted.
3. The largest PCB by area in the power supply unit (internal/external) must be tested for bromine and chlorine (see clarification below).

Maximum concentration values tolerated for a non-accepted substance (including decaBDE) is 0.1% by weight of the material in homogeneous materials.

Fluoroorganic additives, used to modify the dripping behavior of plastics in fire conditions or to improve the processing behavior, are exempted provided that they do not exceed 0.5% by weight of the material in homogeneous materials.

Submit the following to an approved verifier:

- A copy of the test report(s) from any laboratory accredited according to ISO 17025 covering the largest PCB in the power supply.
- The worst-case concentration levels of any non-accepted substances by weight of the material in homogeneous materials.

The following is submitted to TCO Development:

- A copy of the test report(s) from any laboratory accredited according to ISO 17025 and a copy of the verification report(s) from a verifier approved by TCO Development.

7.2.2 Clarification

1. Applies to product housing parts above 0.5 grams. This includes the product stand and the housing of the external power supply. The internal or external power supply socket or inlet is included in the definition of product housing.

PCB laminates completely sealed within an electronic component are exempted.

External cables are those delivered with the product and are provided to supply power to the product and connect the product to an external peripheral (USB-USB, HDMI-HDMI, HDMI-DP, VGA-VGA, etc). External cables that are permanently attached to a peripheral delivered with the product are not included in the requirements.

See mandate for non-halogenated substances for the requirements on safer substitution.

2. Applies to the whole product, including components, parts and raw materials in all assemblies and sub-assemblies, such as batteries, paint, surface treatment, plastics, electronic components and printed wiring boards.

3. Applies to the testing for bromine and chlorine where the following is required:

The largest PCB by area in the power supply unit must be tested for bromine and chlorine. The PCB must be tested in its final state with PCB laminates included but does not need to be tested with electrical components attached. Testing must be conducted through either IEC 62321-3-1:2013, 62321-3-2:2020 or EN14582 by an ISO 17025 accredited laboratory. If the same PCB is used in multiple products, a test report may be used for multiple products if traceability between the tested sample and the product is verified.

- If indications of bromine or chlorine >0.1% are discovered, the applicant must proceed with additional testing to prove compliance with this criterion.
- If the concentration of a detected substance is <0.1%, then no additional testing is needed.

References

1. EU Directive 2011/65/EU restriction of EEE hazardous substances.
2. Regulation concerning Registration, Evaluation, Authorisation and Restriction of Chemicals (REACH), EC 1907/2006

7.3 Non-halogenated substances

Background

Hazardous non-halogenated substances are problematic in the manufacturing and material recovery phases where workers and the environment can be exposed, leading to human health and environmental risks. This criterion aims to increase the knowledge of which non-halogenated substances are used in certified products, how hazardous they are to human health and the environment, and to drive a shift toward less hazardous alternatives.

This mandate uses the chemical hazard assessment and decision logic framework GreenScreen® for Safer Chemicals, developed by the non-profit organization Clean Production Action (CPA), and the ChemFORWARD hazard banding system based on the Cradle to Cradle Material Health Assessment Methodology.

Both methods align with international standards and regulations that assess chemicals' human health and environmental risks. These include the Regulation on the classification, labelling and packaging of substances and mixtures (CLP), the Globally Harmonized System of Classification and Labelling of Chemicals (GHS), OECD testing protocols, European REACH Regulation that includes RoHs, POPs, SVHCs and the U.S. EPA's Design for Environment (DfE) Alternatives Assessment.

Definitions

Licensed GreenScreen Profilers and ChemFORWARD qualified assessors: Independent toxicology firms licensed/qualified by CPA/ChemFORWARD to provide assessment services for a fee to clients.

TCO Certified Accepted Substance List: Public list of independently assessed safer available alternatives considering toxicity and functionality.

An electronic component is considered an individual part or combination of parts that when together, perform a design function(s) and are typically directly attached to a printed circuit board. Internal and external power supplies are not included in the definition.

Product housing protects internal components and safeguards the user against injury from these electrical components. Product safety standards define these safeguards as different types of protective enclosures. These enclosures are added to safeguard against electrical shock, high temperatures, fire and mechanical (moving parts such as the fan), and radiation (such as any internal laser), whilst also protecting internal parts.

External cables delivered with the product: Cables that provide power to the product and cables that connect the product to an external peripheral (USB-USB, HDMI-HDMI, HDMI-DP, VGA-VGA, etc).

Applicability

All product categories.

7.3.1 Mandate

Product housing parts, printed circuit board (PCB) laminates, and external cable parts above 0.5 grams must only contain intentionally added (additive or reactive) non-halogenated flame retardants and vinyl polymer stabilizers that appear on TCO Certified Accepted Substance List.

Exempted are all other parts, such as electronic components and PCB laminates sealed inside electronic components.

Submit the following to an approved verifier:

- For any substance to be added to the Accepted Substance List, a document copy or access to a database copy of the certified assessment report conducted and issued by a licensed GreenScreen Profiler must be provided.

The following is submitted to TCO Development:

- A copy of a verification report from a verifier approved by TCO Development.
- A document copy or access to a database copy of the certified assessment report conducted and issued by a licensed GreenScreen Profiler.

7.3.2 Clarification

All substances of a flame retardant and stabilizer mixture must be accounted for.

Non-accepted substances must not exceed concentration levels of 0.1% by weight of the flame retardant and stabilizer.

Product housing parts include the product stand and the housing of the external power supply. The internal or external power supply socket or inlet is included in the definition of product housing.

Only PCB laminates completely sealed within an electronic component are exempted.

External cables delivered with the product are considered cables provided to supply power to the product, and to connect the product to an external peripheral (USB-USB, HDMI-HDMI, HDMI-DP, VGA-VGA, etc). External cables that are permanently attached to a peripheral delivered with the product are not included in the requirements.

TCO Certified Accepted Substance List

Non-halogenated flame retardants can be used in certified products once they receive an accepted GreenScreen benchmark or ChemFORWARD hazard band, and appear on the public TCO Certified Accepted Substance List. GreenScreen benchmarks 2, 3 or 4 assigned by a licensed GreenScreen profiler or hazard bands A, B or C assigned by a qualified ChemFORWARD assessor are accepted to appear on TCO Certified Accepted Substance List. A GreenScreen benchmark U may only be accepted when the “worst case scenario” for data gaps is considered a benchmark 2 or above. The list is dynamic, which allows new substances that have undergone a valid assessment to be added at any time. Accepted substances may be reassessed in light of new scientific findings.

TCO Development must have access to a copy of the GreenScreen and ChemFORWARD assessment reports before the substance can be added to TCO Certified Accepted Substance List.

Conformity procedure

- When suppliers confirm that all substances relevant to this mandate are on the TCO Certified Accepted Substance List and the verifier considers all documentation submitted and compliant, they will issue an environmental verification to the applicant.
- If any substance relevant to this mandate does not yet appear on TCO Certified Accepted Substance List, then it must be added before approval can be given by a verifier. An extended time period to comply can be applied here (see “Applying for an extended period...” below).
- TCO Development will require manufacturers to disclose substance details used in randomly chosen products. To verify that the obligations according to this mandate are fulfilled CASNR disclosure and laboratory assessments of selected parts will be conducted to assess the completeness, quality and validity of a benchmark score.

Get a substance assessed and added to TCO Certified Accepted Substance List:

- First, determine if the substance is restricted or already has a valid assessment available.
 - a. Contact TCO Development to see if the substance is restricted.
 - b. Visit TCO Certified Potential Candidate List to see if a previous assessment has been completed and the profiler/assessor that completed it.
 - c. Visit the GreenScreen Assessment Registry or contact ChemFORWARD to see if a valid assessment is available.
- If the substance needs an assessment and depending on the chemical hazard assessment method chosen, a licensed GreenScreen profiler is found on the Clean Production Action website, and a qualified ChemFORWARD assessor is found on the ChemFORWARD website.
- Next, an extensive chemical hazard assessment will be assembled by the profiler/assessor from the available information (literature search, structural similarity comparison, expert judgment) covering human and environmental toxicology endpoints in accordance with GreenScreen or ChemFORWARD requirements
- The profiler/assessor sets the benchmark/hazard band per relevant substance. The assessment report is then valid for up to five years.
- Complete assessment reports must be submitted to TCO Development for final approval before a substance is added to TCO Certified Accepted Substance List.
- When the substance is added to the TCO Certified Accepted Substance List, it shows only the substance’s name, CASRN, type of additive, benchmark/hazard band, date of the assessment and profiler/assessor company name.
- Once a substance is added to the list and the environmental verifier identifies it, they will issue the environmental verification.

A substance being removed from TCO Certified Accepted Substance List:

- When the validity of a GreenScreen/ChemFORWARD assessment (5 years) has expired and not been updated, TCO Development will consider that the substance is no longer being used on certified products. In this case, the substance will be moved to TCO Certified Potential Candidate List.

- If a substance benchmark/hazard band has been degraded during its five year validity to a non-accepted benchmark/hazard band, it must be removed. The substance can continue to be used for up to 18 months from the degraded date. The removal date will be visible on the TCO Certified Accepted Substance List.

Applying for authorization for an extended period to substitute or add a substance to TCO Certified Accepted Substance List

Applicants signing the mandate must first seek authorization for an extended period to complete hazard assessments or substitute a restricted substance not on TCO Certified Accepted Substance List. The applicant must complete a risk assessment questionnaire and submit it to TCO Development. The risk assessment requires the applicant to clarify why an extension is necessary, provide information on the chemical and its substitute, and include a timeline for completing the assessment and/or substitution. If an extension application is not granted, the applicant must ensure that all used flame retardant, plasticizer or stabilizer formulations only include substances on TCO Certified Accepted Substance List before an environmental verification can be issued for the product model. If an extension due date is exceeded without conformity, the verifier must contact TCO Development, and a course of action will be decided upon after discussing the issue with the applicant.

References

1. <https://www.greenscreenchemicals.org/>
2. <https://www.chemforward.org/>
3. <https://pharos.habitablefuture.org/>

7.4 Plasticizers

Background

Plasticizers are increasingly associated with negative environmental and human health impacts. RoHs is a restricted substances list that, beginning in 2019, restricts the use of four phthalates. TCO Development is committed to taking a much broader approach by identifying and restricting not only these four but all substances of high concern used in IT products. Our criteria are, therefore, designed to make sure that replacement substances are independently assessed as safer alternatives and that transparency increases. The full list of safer alternatives is available on tco-certified.com.

This mandate uses the chemical hazard assessment and decision logic framework GreenScreen® for Safer Chemicals, developed by the non-profit organization Clean Production Action (CPA), and the ChemFORWARD hazard banding system based on the Cradle to Cradle Material Health Assessment Methodology.

GreenScreen criteria align with international standards and regulations that assess chemicals on their human health and environmental hazards. These include the Regulation on the classification, labelling and packaging of substances and mixtures (CLP), the Globally Harmonized System of Classification and Labelling of Chemicals (GHS), OECD testing protocols, European REACH Regulation that includes RoHs, POPs, SVHCs and the U.S. EPA's Design for Environment (DfE) Alternatives Assessment.

Definitions

Plasticizer: An additive to a polymer (plastic), to increase its flexibility, transparency, durability, or longevity.

Phthalates: The most common type of plasticizer in PVC cables.

Licensed GreenScreen Profilers and ChemFORWARD qualified assessors: Independent toxicology firms licensed/qualified by CPA/ChemFORWARD to provide assessment services for a fee to clients.

TCO Certified Accepted Substance List: Public list of independently assessed safer available alternatives considering toxicity and functionality.

Product housing is the external enclosure or casing that protects the product's internal parts. This includes the product stand.

An electronic component is considered an individual part or combination of parts that when together, perform a design function(s) and are typically directly attached to a printed circuit board. Internal and external power supplies are not included in the definition.

External cables delivered with the product: Cables that provide power to the product and connect the product to an external peripheral (USB-USB, HDMI-HDMI, HDMI-DP, VGA-VGA, etc).

Applicability

All product categories.

7.4.1 Mandate

- Product housing and cable/wire parts above 0.5 grams must only contain intentionally added plasticizers that appear on TCO Certified Accepted Substance List. Exempted are connectors and wires sealed inside electronic components.
- The product must not contain Bis (2-ethylhexyl) phthalate (DEHP), Butyl benzyl phthalate (BBP), Dibutyl phthalate (DBP), and Diisobutyl phthalate (DIBP). No parts of the product are exempted.

All substances of a plasticizer mixture must be accounted for. Non-accepted ingredients must not exceed concentration levels of 0.1% by weight of the plasticizer.

Submit the following to an approved verifier:

- For any substance to be added to the Accepted Substance List, a document copy or access to a database copy of the certified assessment report conducted and issued by a licensed GreenScreen Profiler must be provided.
- The worst-case concentration levels by weight of any restricted plasticizers must be provided.

The following is submitted to TCO Development:

- A copy of a verification report from a verifier approved by TCO Development.
- For new or revised substances to be added to ASL, a document copy or access to a database copy of the complete assessment report conducted and issued by an approved GreenScreen licensed profiler.

7.4.2 Clarification

The worst-case concentrations reported for restricted plasticizers (Bis (2-ethylhexyl) phthalate (DEHP), Butyl benzyl phthalate (BBP), Dibutyl phthalate (DBP), and Diisobutyl phthalate (DIBP)) must be signed by the brand owner and may cover several products.

The mandate applies to product housing and cable/wire parts above 0.5 grams. This includes internal and external power supply housing and external cables. Exempted are wires completely sealed within an electronic component such as a HDD, SSD or ODD. Also, external cables permanently attached to a peripheral delivered with the product.

Examples of cable/wire parts include: Internal product cables that interconnect between components and are detachable at both ends, such as power and data/signal cables. Cables permanently attached to electronic components, such as fans and speakers. External cables delivered with the product are considered cables provided to supply power to the product and connect the product to an external peripheral (USB-USB, HDMI-HDMI, HDMI-DP, VGA-VGA, etc).

TCO Development must have access to a copy of the GreenScreen and ChemFORWARD assessment reports before the substance can be added to TCO Certified Accepted Substance List.

For more clarifications on adding substances to TCO Certified Accepted Substance List and accepted hazard assessment frameworks, see non-halogenated substances 7.3 clarifications

References

1. <https://www.greenscreenchemicals.org/>
2. <https://www.chemforward.org/>
3. <https://pharos.habitablefuture.org/>.

7.5 Hazardous substances in product packaging

Background

The use of hazardous substances in packaging materials is problematic and should be minimized. It poses a risk to human health and the environment, not least because packaging materials have a short lifespan and generate large volumes of waste. Several hazardous substances are regulated in many countries, and the use of them should be phased out.

Applicability

All product categories.

7.5.1 Mandate

The packaging material must not contain lead (Pb), cadmium (Cd), mercury (Hg) or hexavalent chromium (Cr6). Plastic packaging material must not contain organically bound halogens.

Submit the following to an approved verifier:

- The worst-case concentrations by weight in the packaging material.

The following is submitted to TCO Development:

- A copy of a verification report from a verifier approved by TCO Development.

7.5.2 Clarification

The worst-case concentration report must be signed by the brand owner and may cover several products.

Limit values are according to Directive 94/62/EC on packaging and packaging waste.

References

1. Directive 94/62/EC on packaging and packaging waste.

8 Material recovery

- More than 60 million metric tons of e-waste is generated every year and only a small amount is handled in a safe way.
- This leads to pollution, human health hazards and the loss of valuable finite resources.
- For a more sustainable life cycle, products and materials must be recovered and reused to a much larger extent.

Material waste – a multi-faceted sustainability issue

Today's unsustainable handling of e-waste leads to pollution, health hazards and the loss of valuable natural resources, such as copper, gold and rare earth metals. According to the United Nations University, electronic waste is the fastest-growing waste stream in the world, with more than 60 million metric tons generated every year. It is estimated that only about 22 percent of the waste is handled in a proper way. The rest is unaccounted for and risk being incinerated, placed on scrap heaps, or illegally exported to developing countries, often to destinations lacking effective legislation that regulates how e-waste should be managed. In these countries, products are manually disassembled, burned in the open air or dissolved in acid by local laborers including children, without adequate protective equipment – leading to severe health problems.

Packaging is also a sustainability issue. Its lifetime is short and generates large volumes of waste. Using several types of materials that are difficult to separate makes recycling a challenge.

Our approach: prevent e-waste and recover materials safely

The most important way of reducing e-waste is to use products longer. Read more about this in chapter 6. Once products have reached the end of their usable life, they must be collected for remanufacturing, refurbishing or recycling. Product packaging must be designed in a way that enables reuse and recycling.

Criteria in chapter 8 focus on:

- Saving natural resources and limiting hazardous waste by requiring that all packaging materials must be easily separable if not reusable.
- Increase the use of post-consumer recycled plastics in product packaging when other non-plastic materials cannot be substituted.
- Requiring brand owners to implement product take-back systems for a significant portion of their certified products and to use certified recycling facilities that adhere to recognized environmental and safety standards.

8.1 Product packaging

Background

Packaging is a well-known environmental problem that is regulated in many countries worldwide. Packaging material has a short lifetime and generates large volumes of waste. More than 50% of global waste ends up in landfills or open dumps.

- To reduce the waste generated by packaging materials, it shall be possible to separate them into single material types without the use of tools so that material can be recycled instead of becoming waste.
- Even for packaging materials that may be separated into single materials, little of the plastic is properly recycled. Plastics that degrade into microplastics should be prevented from entering landfills or waterways, as the incomplete degradation process leads to the accumulation of highly mobile microplastics in the environment.

Applicability

All product categories.

8.1.1 Mandate

- All parts of the packaging of the certified product weighing more than 25 grams must be possible to separate into single material types without the use of tools.
- For product packaging solutions that are comprised of $\geq 20\%$ plastic, by weight of all packaging materials, the following must be fulfilled:
 - $\geq 50\%$ of the total plastic packaging must be composed of post-consumer recycled plastics, by weight.

Submit the following to an approved verifier:

- Completed post-consumer recycled content template - packaging section.
- Document proof from the material vendor must be provided for each part containing post-consumer recycled plastics.

The following is submitted to TCO Development:

- A copy of the verification report(s) from a verifier approved by TCO Development.

The following is submitted to TCO Development and may be published:

- Total weight of all packaging materials
- Total weight of all plastic content in the packaging solution
- Total weight of post-consumer recycled plastic materials

8.1.2 Clarification

Packaging solutions that contain more than one individual product are not covered by the mandate, such as bulk packaging solutions.

Document proof from the material vendor must be provided for each part containing post-consumer recycled plastics if it is to be included in the PCR percentage. If no proof exists, then 0% must be reported.

The following information must be submitted to an approved verifier

For each packaging part weighing more than 0,5g, the following must be reported in the “postconsumer recycled content & packaging template”, packaging tab:

- Material Type
- Weight of part
- Weight of plastics in part
- Weight of PCR plastic content
- PCR material manufacturer name
- PCR material identifier

The post-consumer recycled content & packaging template is available at tcocertified.com/certification-documents

8.2 E-waste management

Background

Enormous amounts of e-waste is generated every year. It is one of the world's fastest growing waste streams, and much of it is exported to developing countries, burdening local communities with this global problem. Unsafe handling of e-waste causes pollution, human health hazards and the loss of valuable, finite resources. The Basel Convention governs the export of many types of electronic waste, however, it is not properly implemented in all countries. To help reduce the e-waste problem, manufacturers need to provide mechanisms to take back their products. This is consistent with the principle of individual producer responsibility, where each brand owner is financially responsible for managing its own branded products at end-of-use. The purpose of this criterion is to influence the expansion of better electronic waste management practices to more countries.

Definitions

Brand owner: The company or organization owning or controlling the brand name.

EPR: Extended Producer Responsibility

Applicability

All product categories.

8.2.1 Mandate

The brand owner must annually complete the e-waste management template and prove that:

- At least 80% of all certified products sold are covered by product take-back systems.
- At least 40% of all first-tier reuse- and recycling facilities used by non-EPR take-back systems are certified according to R2, e-Stewards, WEEELABEX, EN50625, or equivalent.

Submit the following to an approved verifier:

Annually before 31 August:

- A filled-out TCO Certified E-waste management template covering the previous calendar year.

The following is submitted to TCO Development:

- A copy of the verification report(s) from a verifier approved by TCO Development.
 - The e-waste management template must be uploaded annually in TCO Certified Portal
-

8.2.2 Clarification

Reporting period

The reporting must be submitted by 31 August each year. Each reporting period is the previous calendar year. The reporting applies until one year after the certificate has expired.

Reporting and verification guideline

The brand owner must complete the E-waste management template. In this template, the brand owner will provide the following information:

1. The number and weight of certified products that were manufactured per product category.
2. The take-back volume of products (in kg) by the brand owner for each product category. (take-back carried out by EPRs systems, which is mandatory/approved by local law/government are excluded)
 - a. The weight (in kg) of products processed for Reuse
 - b. The weight (in kg) of products processed for Recycling
3. The name and weblink to all used take-back systems (EPR and non-EPR).
4. All countries where certified products are sold, their sales percentage, and existing take-back systems.
5. The name and address of all first-tier reuse- and recycling facilities used by the non-EPR take-back systems to process the products.
 - a. The certificates held by the first-tier reuse- and recycling facilities used to process the products. (i.e. R2, e-Stewards, WEEELABEX, EN50625, or equivalent.)

The e-waste management template can be found at

<https://tcocertified.com/certification-documents/>

The number of certified products that were manufactured can be reported per product category.

If take-back systems are in place in all countries where the certified product is sold, sales volumes per country do not need to be reported in the template.

Products collected through the take-back system do not need to be of the same brand name as the reporting brand owner.

The brand owner can arrange for product take-back through any system, whether it's an Extended Producer Responsibility (EPR) or a non-EPR system, as long as there's an active contract in place with that system. This includes scenarios where a distributor acts on behalf of the brand owner to manage the product take-back process.

If more than 80% of the brand owner's sales of certified products occur in countries where supporting EPR take-back systems is mandatory by local law, and where distributors handle sales and EPR compliance on behalf of the brand owner, the brand owner is not required to provide contracts between themselves and the EPR take-back systems for those countries. In such cases, the brand owner must still report:

- The sales percentages per country.
- Confirmation that these countries have governmental EPR take-back systems that are mandatory to support under local law.

All other reporting and verification requirements remain the same.

If a brand owner does not use any non-EPR take-back systems but still fulfills “At least 80% of all certified products sold are covered by product take-back systems.”, the “Reuse- and recycling facilities” tab in the E-waste management template is not applicable and can be left empty.

9 Test conditions for tablets

9.1 General test conditions

9.1.1 Definition of a test object

- The product that are subject to tests within this product category are defined in the chapter “About this document”.

9.1.2 Required information about the product

The client must specify:

- Name(s), type designation(s) and manufacturer for all exchangeable parts of the product.
- Display resolution and the vertical and horizontal frequencies for testing.
- Name, type designation and manufacturer of the graphics card. This information must be specified in the test report.

Test conditions

- The product must be delivered to the test facility in test-ready condition and include any required accessories. All necessary information about how to operate and adjust the product must be provided.
- The performance of the tested product must in all aspects, be equal to the product that is delivered to the end user.
- The applicant must inform the test facility if any image enhancement software or hardware is used.
- The product must be warmed up for at least 30 minutes or until it is stabilized. If the display is not stable within one hour, the engineer may cancel the test and demand a replacement sample.
- The screen surface must be clean when tested.
- The product must be tested under nominal conditions of input voltage, current, etc. If sold on different markets, the manufacturer must choose one setup that represents the conditions of the country where the largest number of products are sold.
- The product must be tested with a fully charged battery and be plugged into mains during all tests, unless otherwise specified in the test methods.
- The product must be tested without load on any peripheral interface such as USB, firewire or network hub, memory card slot, loudspeakers or similar unless otherwise stated in the test procedure.

9.1.3 Product alignment for testing

The display screen front must be aligned vertically with the possibility to rotate the display $\pm 30^\circ$ around a vertical axis through the centre-point of the screen front. It must also be possible to tilt the screen forwards and backwards $\pm 15^\circ$ around a horizontal axis through the same centre-point.

9.1.4 Settings of the tablet computer

- If present, the standard controls of the product must be used to configure and adjust the display, e.g. brightness, contrast and correlated colour temperature.

- If possible, the tablet resolution must be set to the native resolution and be used for all test parameters.
- The measurement must be taken with the tablet computer in default CCT. If no default CCT is given or available the colour temperature presented by the recall function (or equivalent function) in the On Screen Display. If no On Screen Display exists, the default CCT on start-up must be used.
- The settings must be the same for all tests, if not specified otherwise in the test method. An external control unit that is not a standard part of the tablet computer is not allowed.
- The test program must have the same, or a higher, color depth as the tested product (6 or 8 bits per color channel).
- The operating system most likely to be used by an end user should be used for testing. All settings in the operating system must be the default ones as delivered to the end user or the default as it appears directly after the installation of the operating system.
- Integrated automatic sensors and any eco-mode functions enabled by default on the display must be disabled by the test engineer for all tests, as long as by doing so the default CCT setting does not change.

9.1.5 Test image/test character

- All test images can be found on tcocertified.com.
- The default testing polarity is positive polarity (black characters on a white background).
- All parts of the tests must be carried out using the same font, character size, correlated color temperature, resolution, operating system and other settings of the tablet computer controls etc., unless otherwise stated in the test procedure.

9.1.6 Test image and test luminance setting

The test image in figure 9.1.7., referred to as the TCO Certified default test image, has an 40% image loading. The test image must fill the whole usable screen that represents the “full screen mode”. This image must be used for testing unless otherwise specified in the test procedure.

If the measured display is not affected by image loading, alternative images may be used (described in *procedure* below) instead of the default test image for measurement of *Color gamut*, to minimize the contribution of stray-light for some measurement equipment. If this method is selected, pay extra attention to displays with dynamic backlight as they may be affected by different levels of image loading.

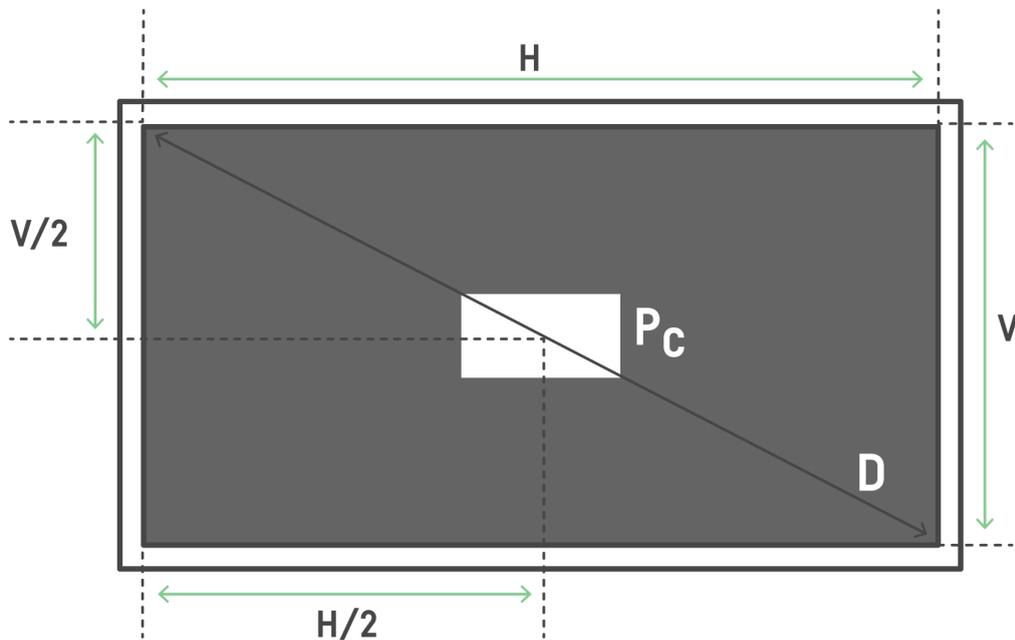

Figure 9.1.7 The TCO Certified default test image. **H** - horizontal size of the active area of the screen. **V** - vertical size of the active area of the screen.

Procedure:

- The background color must be set to RGB 102,102,102 (i.e. equal to 40 % image loading).
- An active white measurement area at the centre of the screen must have a size that is 4% of the active screen size and have an RGB setting of 255, 255, 255.
- A permitted alternative to the 4% active screen size measurement area when testing **Color gamut** is to increase the measurement area to a size that is equal to 80% of the active screen size. The background must continue to be RGB 102, 102, 102.

Test luminance setting

The luminance of the product must be adjusted to $\geq 125 \text{ cd/m}^2$. Test luminance must be as close to, but never lower than 125 cd/m^2 . To achieve an acceptable image quality, proceed as follows:

Use the TCO Certified default test image with an 18-step grayscale pattern (see figure *Luminance level 1*) presented on the display at the default CCT setting. The controls of brightness and contrast, if available, must be adjusted to get the best visual performance of the pattern at the test luminance level. The contrast must keep the default setting. The brightness control must be adjusted to set the display luminance at $\geq 125 \text{ cd/m}^2$. If the possibility of backlight adjustment exists, it must not be used unless specified by the manufacturer. The aim is to get the 18-step grey scale pattern optimized so that at least 15 of 18 grayscales are visible at the test luminance level. If grayscale quality is not acceptable it may be improved by changing the contrast setting, if available. The evaluation of attaining at least 15 of the steps in the 18-step grayscale must be carried out orthogonally to the screen surface.

9.1.7 Instruments used for testing

All instruments used for testing must be calibrated and there must be a valid calibration report. Calibration must be done before the tests are carried out. Calibrations must be traceable to national standards.

9.1.8 Test report

The test results are valid only for the presentation form(s) and configuration(s) that are included in the test. However, configurations may be accepted by the test facility based on tests of a “worst case” configuration. In this case, it must be clearly specified in the test report which of the configurations that have been tested.

The test report must include the following information:

- Any changes to the test methods.
- The manufacturer, brand name, model type and serial number (if available).
- The supply voltage and frequency used during the test and whether it is a CLASS I or CLASS III type. If CLASS III the AC external power supply brand name and model number must also be stated.
- The degree of uncertainty for each given measurement result.
- Photographs of the product showing: front, rear and, if applicable, the external power supply with legible marking label.
- The panel brand name, full panel number and if the display is a pivot type.
- The mode(s) (i.e. horizontal and vertical scan frequency and resolution) used during the test and the aspect ratio.
- If present, the setting of contrast, brightness and CCT preset used during the test.

9.1.9 Overall uncertainty

The overall uncertainty of the test facility must be calculated for each measurement procedure in this document and presented in the test report. The uncertainty must be within the required levels for each criterion. All measurement uncertainties claimed for used instruments must be referred to traceable calibration reports.

About combining overall uncertainty values during test measurements:

- Criteria are fulfilled without adding or subtracting the overall measurement uncertainty.
- Report the value shown on the instrument without adding or subtracting the overall measurement uncertainty.
- The overall measurement uncertainty of the test facility must be printed in the test report together with the reported value.
- If a test facility has an overall measurement uncertainty higher than the one allowed by TCO Development for a certain criterion, then the test report for that criterion is not valid for certification and the test result will not be accepted by TCO Development.

9.2 Visual ergonomics

9.2.1 General test requirements

General test requirements are specified in section 9.1. During all tests, the display screen must be clean.

9.2.2 Photometric test facility general requirements

Photometric measurements must be performed under darkroom conditions. This means that measurement data must in no way be affected by direct light from sources or light reflected from interiors, equipment, clothes etc. The test facility must have a routine for the control of the stray-light level at the tablet computer screen (see also 9.2.6).

9.2.3 Power supply and test room climate requirements for testing

- AC mains voltage* 230 VAC RMS, tolerance $\leq 1 \%$
- AC mains frequency* 50 Hz, tolerance $\leq 2 \%$
- Test room temperature $23 \pm 3 \text{ }^\circ\text{C}$
- Humidity 20-75 % RH (non-condensing)

* – or other voltage and frequency combination specified by the client.

9.2.4 Photometric and spectrometric measurements

Several instruments are to be used when carrying out measurements for visual ergonomics.

The following instrument types are to be used for testing:

- **Luminance meter.** A luminance meter must have a sufficiently good $V(\lambda)$ -sensitivity (Requirements for luminance meters are covered by CIE Publication 69 (1987). Luminance meters of CIE Class L(aboratory) with a combined performance characteristic $\leq 3 \%$ must be used.) and integrate luminance over a finite measuring field during a finite time. The meter must be equipped with adjustable optics and always be focused on the measured area. The luminance meter must incorporate a sufficiently long time constant of integration in order to ensure averaging of the pulsation of the light emitted by tablet computers. The sensitivity must be independent of the polarization of the measured light (often referred to as f_s error).

The luminance meter measuring field must be one degree for all measurements, except for the micro-photometric luminance measurements, see below.

An automated instrument using collimating optics may be used for testing although the measurement area will differ somewhat from the area covered by the luminance meter. When the luminance measurement in this case is done at a shorter measurement distance than required because of instrumental constraints, the facility must verify that the results are equal to those done at the required measurement distance as defined in this document under the headline "Measurement distance".

- **Micro-photometer.** Micro-photometric registration of the luminance distribution of test patterns must be performed with an array photo detector device capable of resolving structures of 0.02 mm. A scanning device must not be used because it is sensitive to jitter and other variations that may occur during a scanning.

- **Spectroradiometer.** An instrument for the measurement of radiant flux as a function of wavelength must be used. A spectroradiometer for the measurement of light and colour is normally equipped with a microprocessor that makes it possible to obtain luminance and colour co-ordinates directly from raw measurement data. A spectroradiometer can replace the luminance meter when suitable. The wavelength resolution must be $\leq 4\text{nm}$ for attaining accurate colour measurements. The sensitivity must be independent of the polarization of the measured light (often referred to as f_s error).

9.2.5 Measurement distance

All measurements must be carried out through a point simulating the operator's eye position. This is defined as a point in front of the centre-point of the display screen at distance of $1.5 \times$ the diagonal of the screen or at the curvature radius of the screen, whichever is smallest. Regardless of the screen size, the distance must never be less than 400 mm, which is considered an absolute minimum distance for comfortably viewing the display. The instrument must be focused on the presented test image for all measurements.

9.2.6 Stray light

Stray light may cause errors which can negatively affect measurement of luminance, contrast and chromaticity coordinates. It is therefore necessary to make an evaluation of stray light influence for the different measurement procedures described in this document. If it is verified that stray light affects the measurement result it is necessary to take actions to eliminate the source of error. Two possible ways to solve the problem are to equip the luminance meter with a well-designed screening attachment, a frustum or to use a black screening sheet at the tablet screen surface.

Note

The uncertainties given are worst case limits. In many cases it will be possible to obtain better accuracy.

